

Moduli space of quadratic differentials from a flat surfaces perspective

Anton Zorich

The Workshop on Quadratic Differentials
AIMS/CMI, Cape Town, January 2016

*“You, my forest and water! One swerves, while the other shall spout
Through your body like draught; one declares, while the first has a doubt.”*

J. Brodsky

*Ты, мой лес и вода, кто обведет, а кто, как сквозняк,
проникает в тебя, кто глаголет, а кто обиняк...*

И. Бродский

0. Model problem: diffusion in a periodic billiard

0. Model problem: diffusion in a periodic billiard

- Diffusion for a random walk
- Lorentz gas: diffusion in periodic billiard
- Diffusion in a periodic billiard (Ehrenfest “Windtree model”)
- Changing the shape of the obstacle
- From a billiard to a surface foliation
- From the windtree billiard to a surface foliation
- Electron transport in metals in homogeneous magnetic field
- Outline of the story

1. Teichmüller dynamics

2. Translation surfaces as quadratic differentials

3. Renormalization and deviation spectrum

2016. State of the art

∞. Challenges and open directions

Diffusion for a random walk and for a brownian motion

Let X_1, \dots, X_n be a sequence of independent and identically distributed random variables (heads or tails, measurements in uncorrelated experiments, etc). Assume that the variance σ^2 is finite and that the expected value is 0. Let $S_n := X_1 + \dots + X_n$. Clearly, with probability one one has

$$\frac{X_1 + \dots + X_n}{n} = \frac{S_n}{n} \rightarrow 0 \quad \text{as } n \rightarrow +\infty.$$

The Central Limit Theorem describes the expected deviation of the sum S_n from 0. In a sense, it is one of the fundamental laws of Nature:

Central Limit Theorem. *The distribution of the the sum S_n normalized by the factor $\frac{1}{\sqrt{n}}$ tends to the normal distribution with mean 0 and variance σ^2 .*

Corollary: random walk or brownian motion in the plane. *The root mean square of the translation distance after n steps of a random walk with zero mean is*

$$\sqrt{E|S_n^2|} = \sigma\sqrt{n} = \sigma \cdot n^{\frac{1}{2}}.$$

Lorentz gas: diffusion in periodic billiard. Convex obstacles

Theorem. (Bunimovich, Chernov, Sinai (1991)). *For periodic configuration of convex scatterers on the plane the particle after scaling by \sqrt{t} satisfies the Central Limit Theorem if the horizon is finite (that is, if any ray intersects a scatterer).*

Theorem. (Szász, Varjú, (2007); some ideas — Bleher (1992)). *In infinite horizon case, for example, for round scatterers placed at the lattice points, the Central Limit Theorem still holds but the scaling should be by $\sqrt{t \ln t}$.*

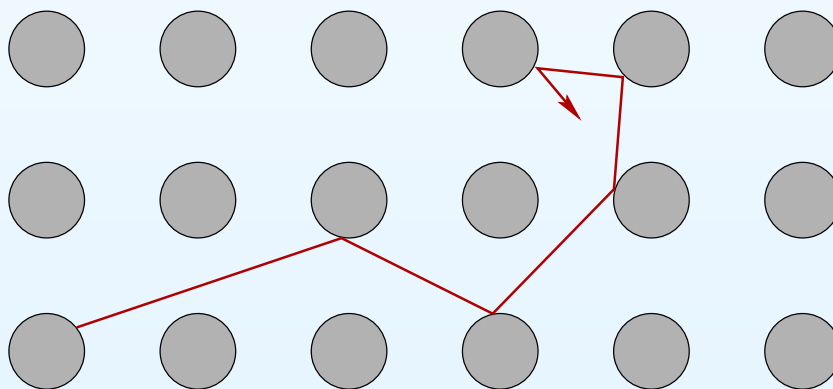

Chernov, Dolgopyat (2009): further interesting results in this direction.

In all cases the *diffusion rate* is again $\frac{1}{2}$ as for the random walk.

Diffusion in a periodic billiard (Ehrenfest “Windtree model”)

Consider a billiard on the plane with \mathbb{Z}^2 -periodic rectangular obstacles.

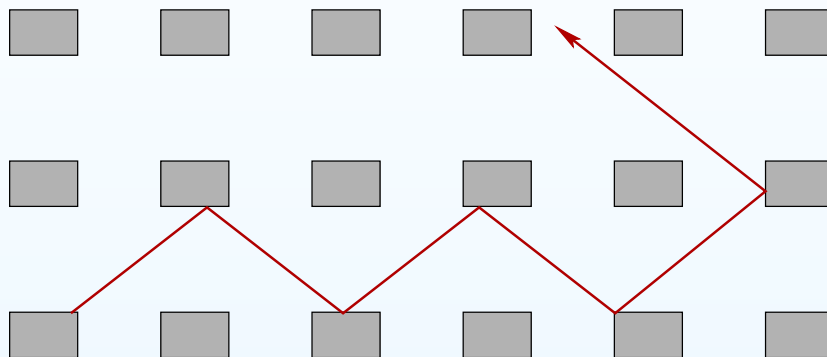

Theorem (V. Delecroix, P. Hubert, S. Lelièvre, 2014). *For all parameters of the obstacle, for almost all initial directions, and for any starting point, the billiard trajectory spreads in the plane with the speed $\sim t^{2/3}$. That is,*

$$\lim_{t \rightarrow +\infty} \log(\text{diameter of trajectory of length } t) / \log t = \frac{2}{3} \neq \frac{1}{2}.$$

The diffusion rate $\frac{2}{3}$ is given by the Lyapunov exponent of certain renormalizing dynamical system associated to the initial one.

Remark. Changing the height and the width of the obstacle we get quite different billiards, but this does not change the diffusion rate!

Diffusion in a periodic billiard (Ehrenfest “Windtree model”)

Consider a billiard on the plane with \mathbb{Z}^2 -periodic rectangular obstacles.

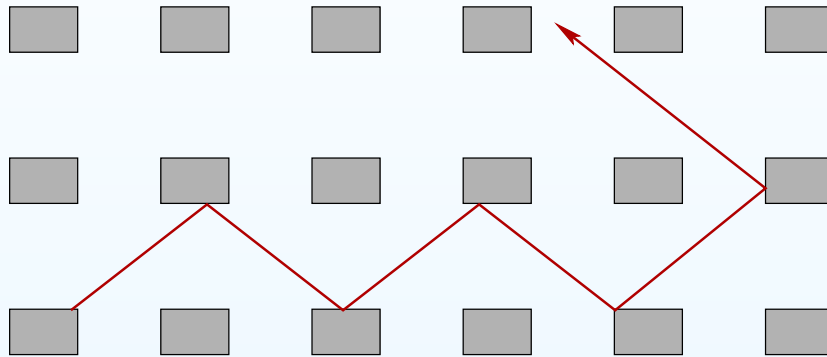

Theorem (V. Delecroix, P. Hubert, S. Lelièvre, 2014). *For all parameters of the obstacle, for almost all initial directions, and for any starting point, the billiard trajectory spreads in the plane with the speed $\sim t^{2/3}$. That is,*

$$\lim_{t \rightarrow +\infty} \log(\text{diameter of trajectory of length } t) / \log t = \frac{2}{3} \neq \frac{1}{2}.$$

The diffusion rate $\frac{2}{3}$ is given by the Lyapunov exponent of certain renormalizing dynamical system associated to the initial one.

Remark. Changing the height and the width of the obstacle we get quite different billiards, but this does not change the diffusion rate!

Diffusion in a periodic billiard (Ehrenfest “Windtree model”)

Consider a billiard on the plane with \mathbb{Z}^2 -periodic rectangular obstacles.

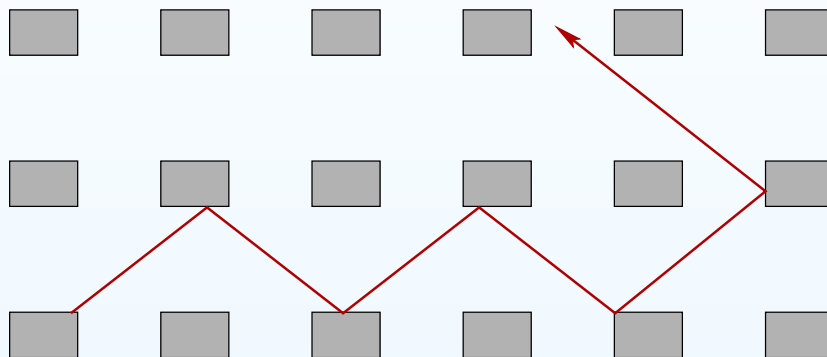

Theorem (V. Delecroix, P. Hubert, S. Lelièvre, 2014). *For all parameters of the obstacle, for almost all initial directions, and for any starting point, the billiard trajectory spreads in the plane with the speed $\sim t^{2/3}$. That is,*

$$\lim_{t \rightarrow +\infty} \log(\text{diameter of trajectory of length } t) / \log t = \frac{2}{3} \neq \frac{1}{2}.$$

The diffusion rate $\frac{2}{3}$ is given by the Lyapunov exponent of certain renormalizing dynamical system associated to the initial one.

Remark. Changing the height and the width of the obstacle we get quite different billiards, but this does not change the diffusion rate!

Diffusion in a periodic billiard (Ehrenfest “Windtree model”)

Consider a billiard on the plane with \mathbb{Z}^2 -periodic rectangular obstacles.

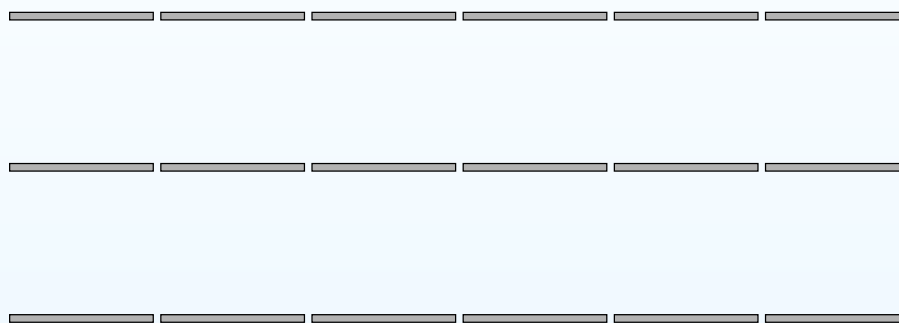

Theorem (V. Delecroix, P. Hubert, S. Lelièvre, 2014). *For all parameters of the obstacle, for almost all initial directions, and for any starting point, the billiard trajectory spreads in the plane with the speed $\sim t^{2/3}$. That is,*

$$\lim_{t \rightarrow +\infty} \log(\text{diameter of trajectory of length } t) / \log t = \frac{2}{3} \neq \frac{1}{2}.$$

The diffusion rate $\frac{2}{3}$ is given by the Lyapunov exponent of certain renormalizing dynamical system associated to the initial one.

Remark. Changing the height and the width of the obstacle we get quite different billiards, but this does not change the diffusion rate!

Diffusion in a periodic billiard (Ehrenfest “Windtree model”)

Consider a billiard on the plane with \mathbb{Z}^2 -periodic rectangular obstacles.

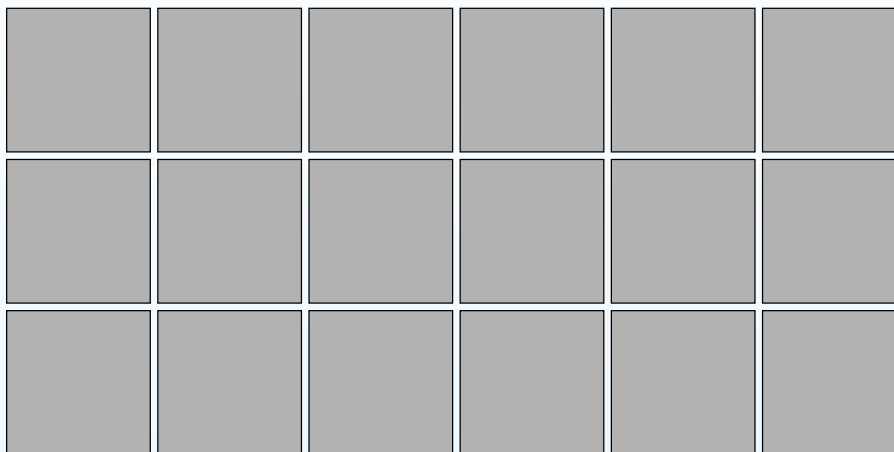

Theorem (V. Delecroix, P. Hubert, S. Lelièvre, 2014). *For all parameters of the obstacle, for almost all initial directions, and for any starting point, the billiard trajectory spreads in the plane with the speed $\sim t^{2/3}$. That is,*

$$\lim_{t \rightarrow +\infty} \log(\text{diameter of trajectory of length } t) / \log t = \frac{2}{3} \neq \frac{1}{2}.$$

The diffusion rate $\frac{2}{3}$ is given by the Lyapunov exponent of certain renormalizing dynamical system associated to the initial one.

Remark. Changing the height and the width of the obstacle we get quite different billiards, but this does not change the diffusion rate!

Changing the shape of the obstacle

Theorem (V. Delecroix, A. Z., 2015). *Changing the shape of the obstacle we get a different diffusion rate. Say, for a symmetric obstacle with $4m - 4$ angles $3\pi/2$ and $4m$ angles $\pi/2$ the diffusion rate is*

$$\frac{(2m)!!}{(2m+1)!!} \sim \frac{\sqrt{\pi}}{2\sqrt{m}} \text{ as } m \rightarrow \infty.$$

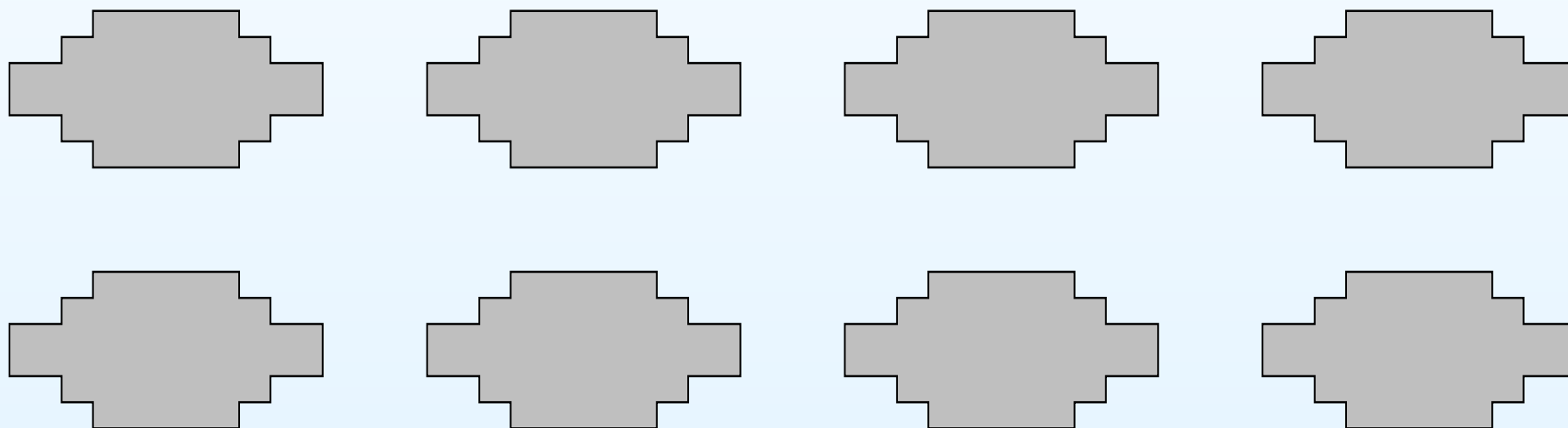

Note that once again the diffusion rate depends only on the number of the corners, but not on the (almost all) lengths of the sides, or other details of the shape of the obstacle.

Changing the shape of the obstacle

Theorem (V. Delecroix, A. Z., 2015). *Changing the shape of the obstacle we get a different diffusion rate. Say, for a symmetric obstacle with $4m - 4$ angles $3\pi/2$ and $4m$ angles $\pi/2$ the diffusion rate is*

$$\frac{(2m)!!}{(2m+1)!!} \sim \frac{\sqrt{\pi}}{2\sqrt{m}} \text{ as } m \rightarrow \infty.$$

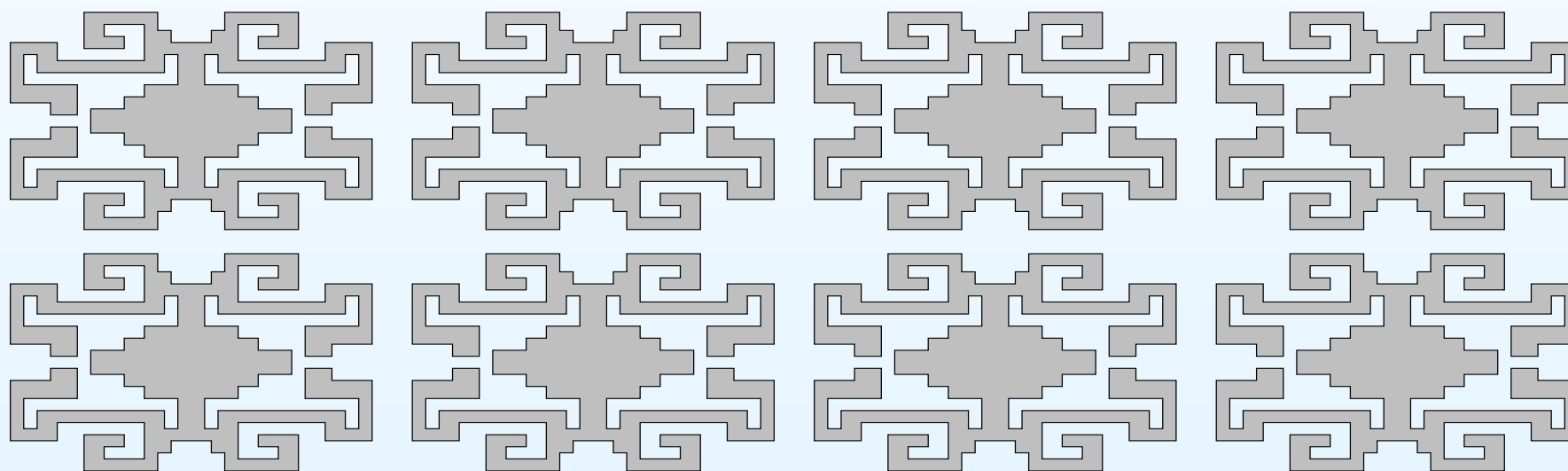

Note that once again the diffusion rate depends only on the number of the corners, but not on the (almost all) lengths of the sides, or other details of the shape of the obstacle.

From a billiard to a surface foliation

Consider a rectangular billiard. Instead of reflecting the trajectory we can reflect the billiard table. The trajectory unfolds to a straight line. Folding back the copies of the billiard table we project this line to the original trajectory. At any moment the ball moves in one of four directions defining four types of copies of the billiard table. Copies of the same type are related by a parallel translation.

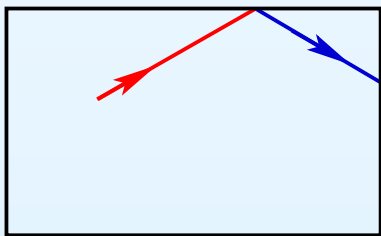

From a billiard to a surface foliation

Consider a rectangular billiard. Instead of reflecting the trajectory we can reflect the billiard table. The trajectory unfolds to a straight line. Folding back the copies of the billiard table we project this line to the original trajectory. At any moment the ball moves in one of four directions defining four types of copies of the billiard table. Copies of the same type are related by a parallel translation.

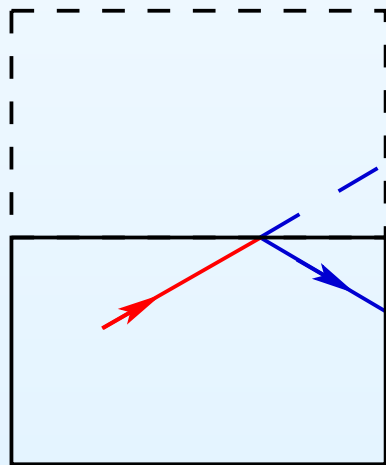

From a billiard to a surface foliation

Consider a rectangular billiard. Instead of reflecting the trajectory we can reflect the billiard table. The trajectory unfolds to a straight line. Folding back the copies of the billiard table we project this line to the original trajectory. At any moment the ball moves in one of four directions defining four types of copies of the billiard table. Copies of the same type are related by a parallel translation.

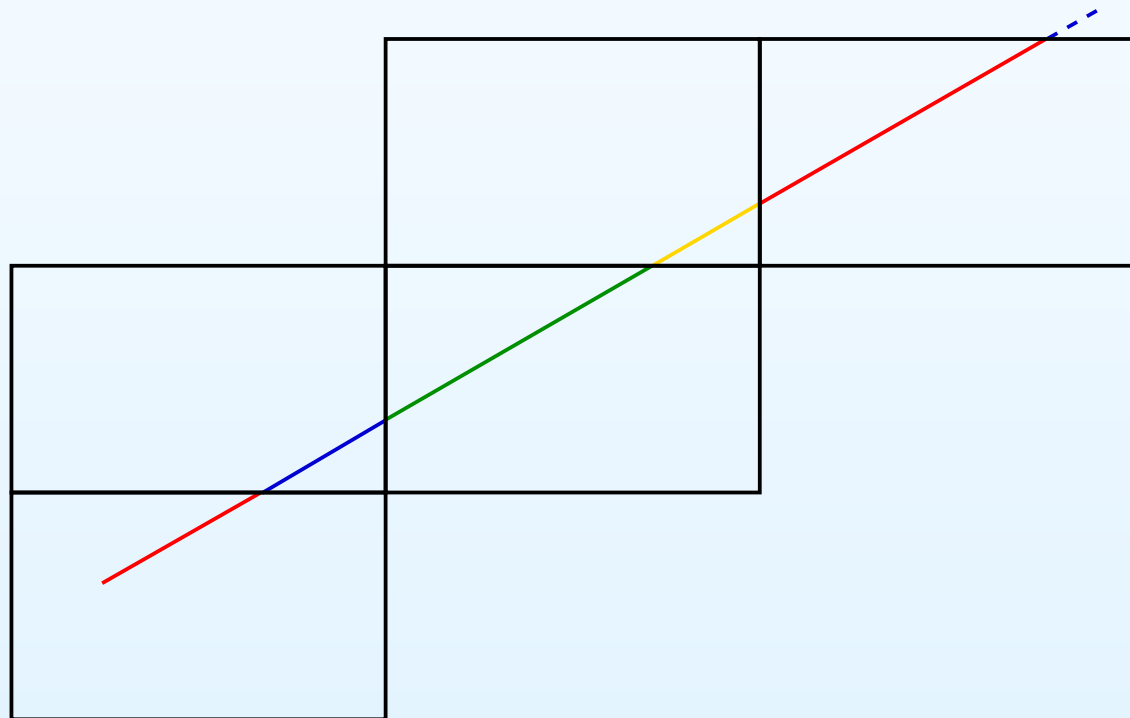

From a billiard to a surface foliation

Consider a rectangular billiard. Instead of reflecting the trajectory we can reflect the billiard table. The trajectory unfolds to a straight line. **Folding back the copies of the billiard table we project this line to the original trajectory.** At any moment the ball moves in one of four directions defining four types of copies of the billiard table. Copies of the same type are related by a parallel translation.

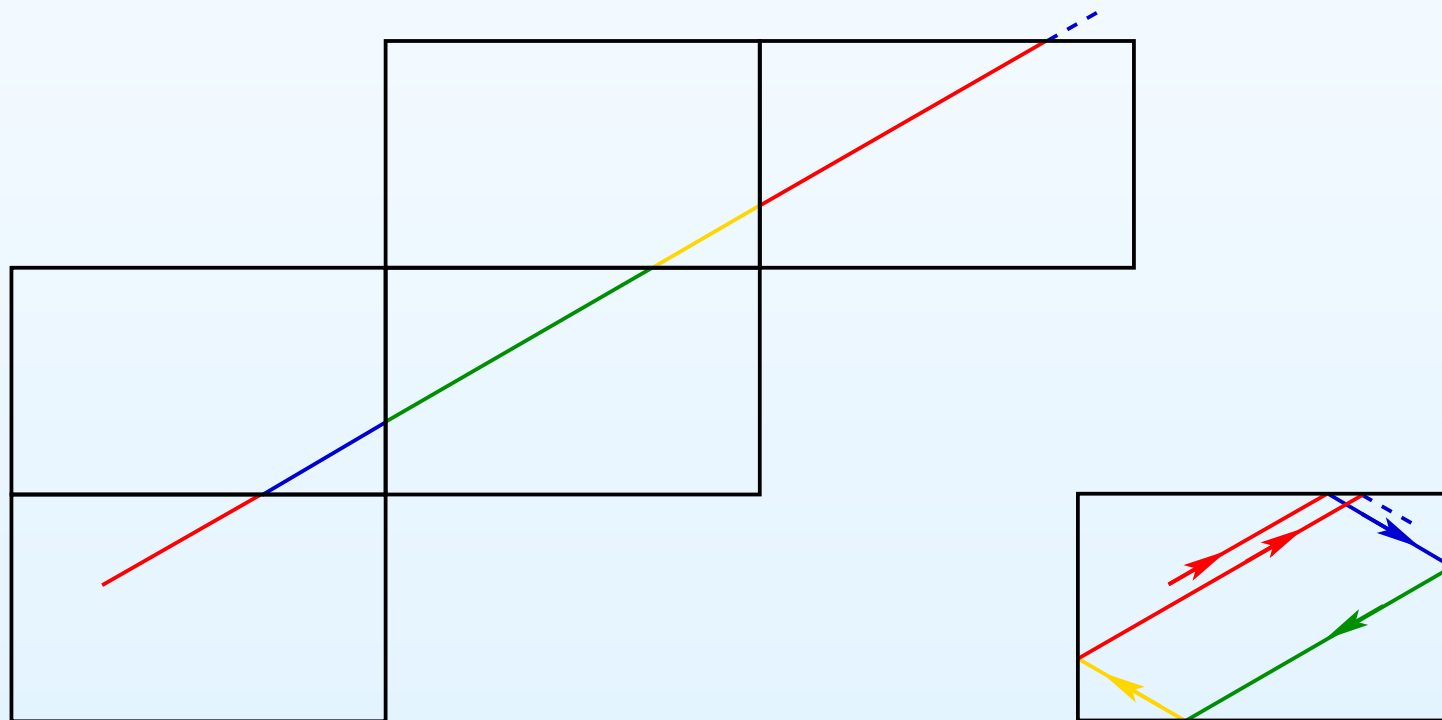

From a billiard to a surface foliation

Consider a rectangular billiard. Instead of reflecting the trajectory we can reflect the billiard table. The trajectory unfolds to a straight line. Folding back the copies of the billiard table we project this line to the original trajectory. At any moment the ball moves in one of four directions defining four types of copies of the billiard table. Copies of the same type are related by a parallel translation.

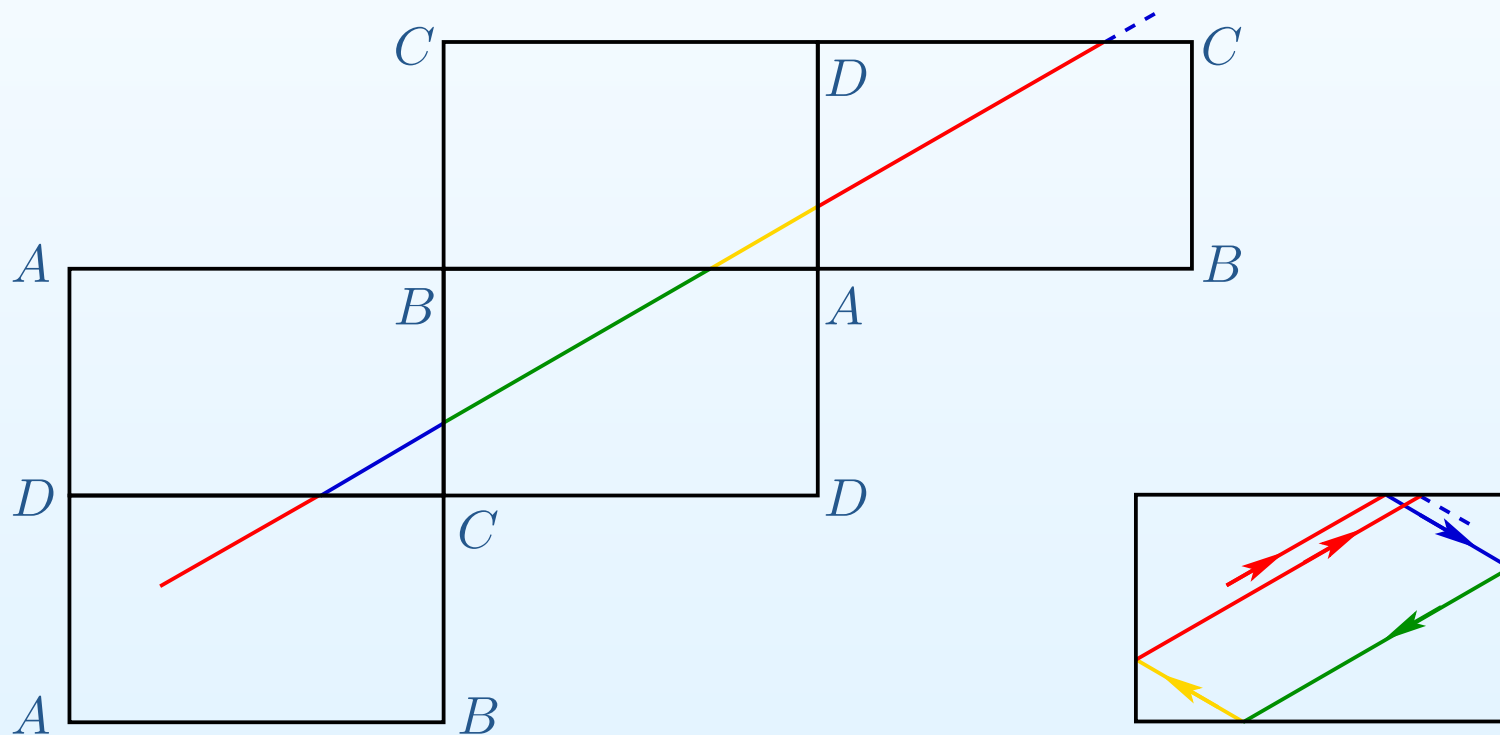

From a billiard to a surface foliation

Consider a rectangular billiard. Instead of reflecting the trajectory we can reflect the billiard table. The trajectory unfolds to a straight line. Folding back the copies of the billiard table we project this line to the original trajectory. At any moment the ball moves in one of four directions defining four types of copies of the billiard table. Copies of the same type are related by a parallel translation.

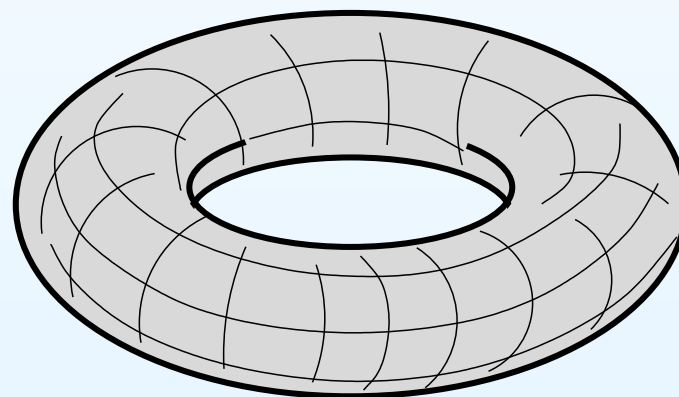
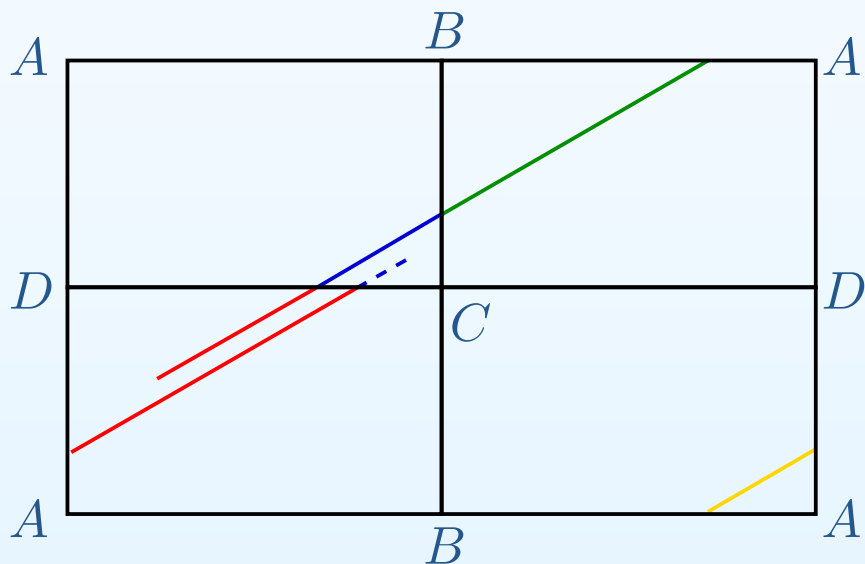

Identifying the equivalent patterns by a parallel translation we obtain a torus; the billiard trajectory unfolds to a “straight line” on the corresponding torus.

From a billiard to a surface foliation

Consider a rectangular billiard. Instead of reflecting the trajectory we can reflect the billiard table. The trajectory unfolds to a straight line. Folding back the copies of the billiard table we project this line to the original trajectory. At any moment the ball moves in one of four directions defining four types of copies of the billiard table. Copies of the same type are related by a parallel translation.

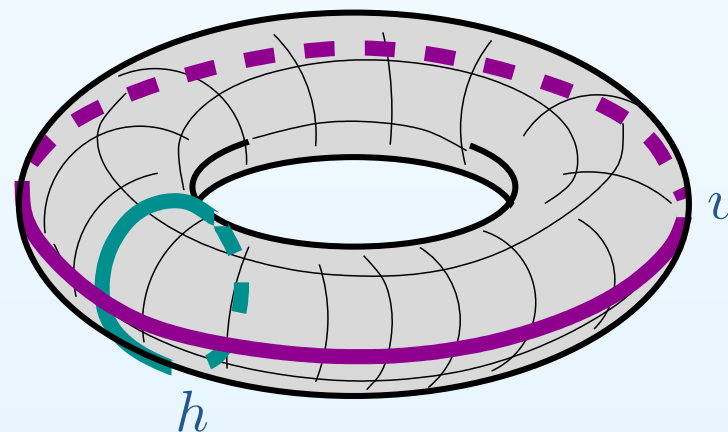
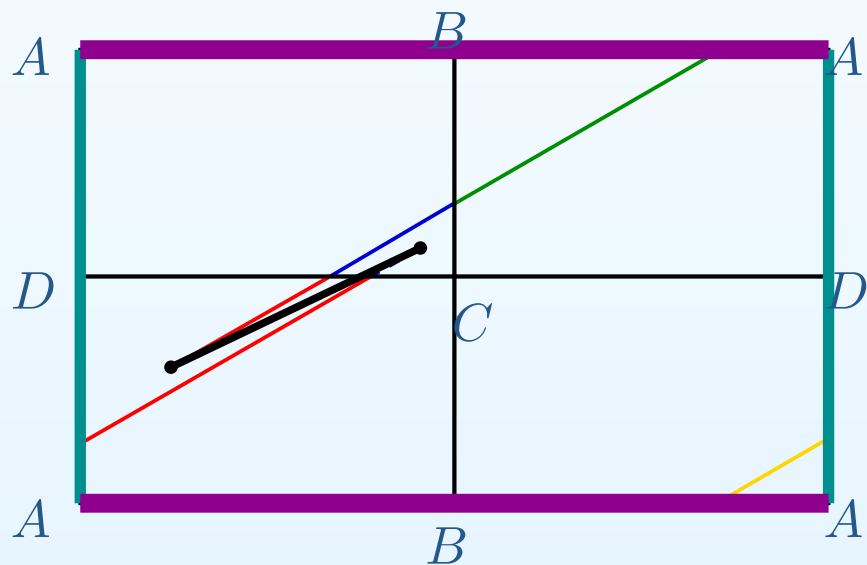

Join the endpoints of a piece of trajectory after time t to obtain a closed loop $c(t)$ on the torus. Vertical and horizontal displacement after time t of the unfolded billiard trajectory is described by the intersection numbers $c(t) \circ h$ and $c(t) \circ v$ with a parallel h and a meridian v of the torus.

From the windtree billiard to a surface foliation

Similarly, taking four copies of our \mathbb{Z}^2 -periodic windtree billiard we can unfold it to a foliation on a \mathbb{Z}^2 -periodic surface. Taking a quotient over \mathbb{Z}^2 we get a compact surface endowed with a measured foliation. Vertical and horizontal displacement (and thus, the diffusion) of billiard trajectories is described by the intersection numbers $c(t) \circ h$ and $c(t) \circ v$ of the cycle $c(t)$ obtained by closing up a long piece of leaf with a “parallel” h and a “meridian” v . Here $h = h_{00} + h_{10} - h_{01} - h_{11}$ and $v = v_{00} - v_{10} + v_{01} - v_{11}$.

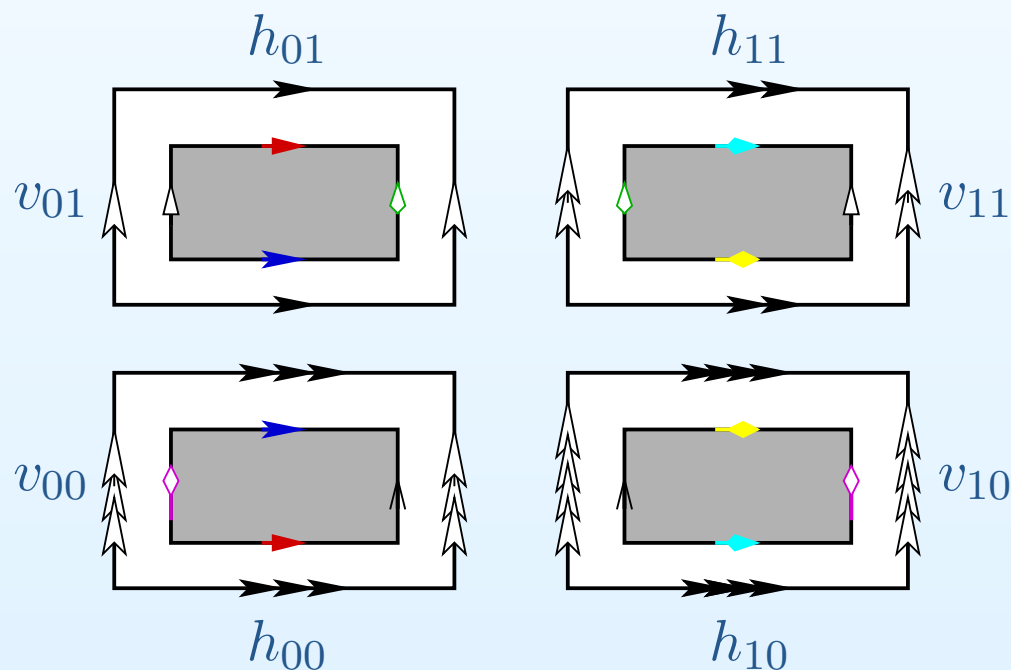

Electron transport in metals in homogeneous magnetic field

Measured foliations on surfaces naturally appear in the study of conductivity in crystals. For example, the energy levels in the quasimomentum space (called *Fermi-surfaces*) might give sophisticated periodic surfaces in \mathbb{R}^3 .

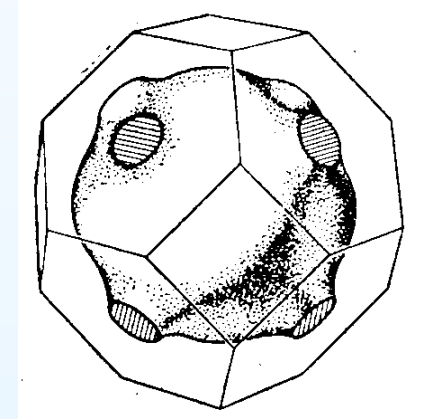
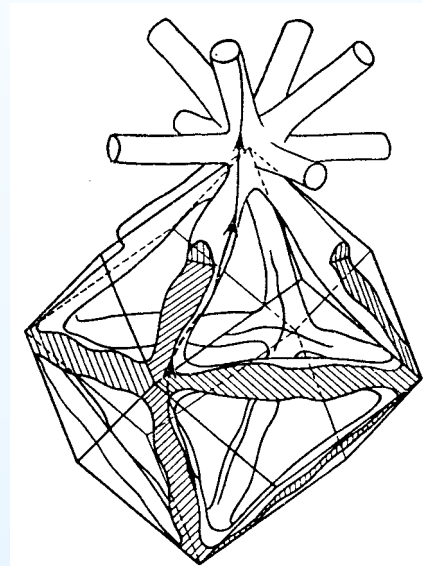
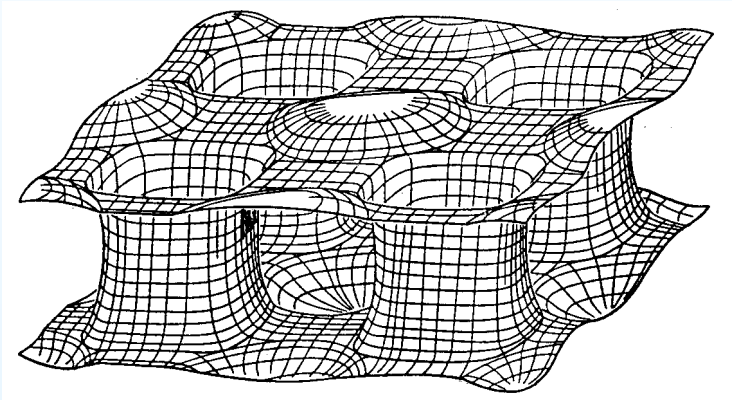

Fermi surfaces of tin, iron, and gold.

Electron trajectories in the presence of a homogeneous magnetic field correspond to sections of such a periodic surface by parallel planes. Passing to the quotient by \mathbb{Z}^3 we get a measured foliation on the resulting compact surface.

Electron transport in metals in homogeneous magnetic field

Measured foliations on surfaces naturally appear in the study of conductivity in crystals. For example, the energy levels in the quasimomentum space (called *Fermi-surfaces*) might give sophisticated periodic surfaces in \mathbb{R}^3 .

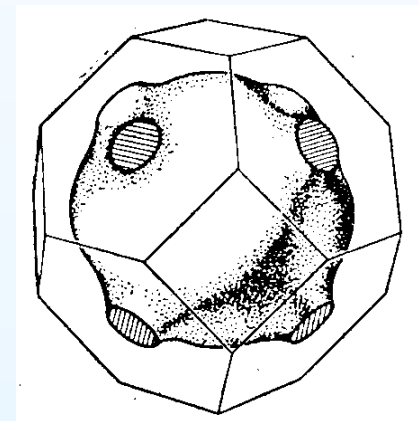
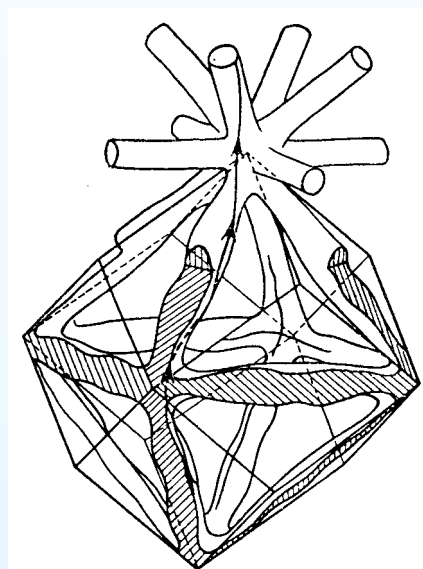
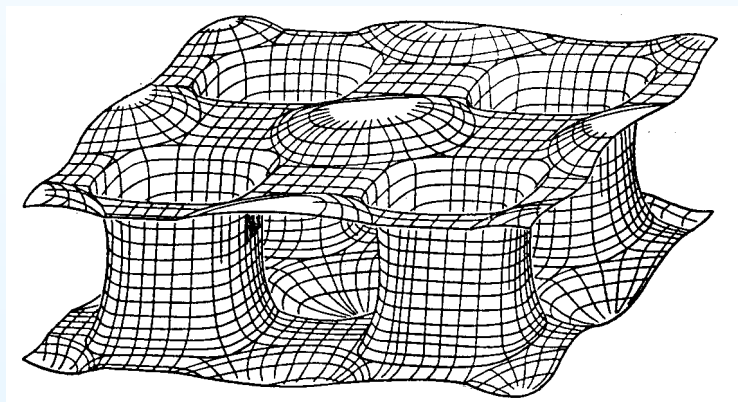

Fermi surfaces of tin, iron, and gold.

Electron trajectories in the presence of a homogeneous magnetic field correspond to sections of such a periodic surface by parallel planes. Passing to the quotient by \mathbb{Z}^3 we get a measured foliation on the resulting compact surface.

Outline of the story

Billiards in polygons, straight line foliations on flat surfaces, horocyclic flows on homogeneous spaces exhibit unusual behaviour of natural mean value quantities.

The corresponding *deviation spectrum* — a finite collection of numbers generalizing the diffusion rate $\frac{2}{3}$ in the windtree model, can be found studying the renormalized dynamical system: the *Teichmüller geodesic flow* acting on the moduli space of quadratic differentials. The fact that one can compute (or estimate) the corresponding numbers comes from a beautiful interplay:

1. Dynamically, the moduli space of quadratic differentials pretends to be a homogeneous space: Eskin–Mirzakhani-Mohammadi have recently proved certain striking rigidity results (specific for homogeneous case).
2. Hodge theory provides rich geometric structure relating Lyapunov exponents and characteristic numbers of holomorphic vector bundles over certain loci in the moduli space first noticed by Kontsevich (talk of Martin Möller).
3. Geometrically, “Masur–Veech” volumes of the moduli spaces can be expressed as sort of Hurwitz numbers first studied by Eskin–Okounkov (talk of Elise Goujard).

Outline of the story

Billiards in polygons, straight line foliations on flat surfaces, horocyclic flows on homogeneous spaces exhibit unusual behaviour of natural mean value quantities.

The corresponding *deviation spectrum* — a finite collection of numbers generalizing the diffusion rate $\frac{2}{3}$ in the windtree model, can be found studying the renormalized dynamical system: the *Teichmüller geodesic flow* acting on the moduli space of quadratic differentials. The fact that one can compute (or estimate) the corresponding numbers comes from a beautiful interplay:

1. Dynamically, the moduli space of quadratic differentials pretends to be a homogeneous space: Eskin–Mirzakhani-Mohammadi have recently proved certain striking rigidity results (specific for homogeneous case).
2. Hodge theory provides rich geometric structure relating Lyapunov exponents and characteristic numbers of holomorphic vector bundles over certain loci in the moduli space first noticed by Kontsevich (talk of Martin Möller).
3. Geometrically, “Masur–Veech” volumes of the moduli spaces can be expressed as sort of Hurwitz numbers first studied by Eskin–Okounkov (talk of Elise Goujard).

Outline of the story

Billiards in polygons, straight line foliations on flat surfaces, horocyclic flows on homogeneous spaces exhibit unusual behaviour of natural mean value quantities.

The corresponding *deviation spectrum* — a finite collection of numbers generalizing the diffusion rate $\frac{2}{3}$ in the windtree model, can be found studying the renormalized dynamical system: the *Teichmüller geodesic flow* acting on the moduli space of quadratic differentials. The fact that one can compute (or estimate) the corresponding numbers comes from a beautiful interplay:

1. Dynamically, the moduli space of quadratic differentials pretends to be a homogeneous space: Eskin–Mirzakhani-Mohammadi have recently proved certain striking rigidity results (specific for homogeneous case).
2. Hodge theory provides rich geometric structure relating Lyapunov exponents and characteristic numbers of holomorphic vector bundles over certain loci in the moduli space first noticed by Kontsevich (talk of Martin Möller).
3. Geometrically, “Masur–Veech” volumes of the moduli spaces can be expressed as sort of Hurwitz numbers first studied by Eskin–Okounkov (talk of Elise Goujard).

Outline of the story

Billiards in polygons, straight line foliations on flat surfaces, horocyclic flows on homogeneous spaces exhibit unusual behaviour of natural mean value quantities.

The corresponding *deviation spectrum* — a finite collection of numbers generalizing the diffusion rate $\frac{2}{3}$ in the windtree model, can be found studying the renormalized dynamical system: the *Teichmüller geodesic flow* acting on the moduli space of quadratic differentials. The fact that one can compute (or estimate) the corresponding numbers comes from a beautiful interplay:

1. Dynamically, the moduli space of quadratic differentials pretends to be a homogeneous space: Eskin–Mirzakhani-Mohammadi have recently proved certain striking rigidity results (specific for homogeneous case).
2. Hodge theory provides rich geometric structure relating Lyapunov exponents and characteristic numbers of holomorphic vector bundles over certain loci in the moduli space first noticed by Kontsevich (talk of Martin Möller).
3. Geometrically, “Masur–Veech” volumes of the moduli spaces can be expressed as sort of Hurwitz numbers first studied by Eskin–Okounkov (talk of Elise Goujard).

Outline of the story

Billiards in polygons, straight line foliations on flat surfaces, horocyclic flows on homogeneous spaces exhibit unusual behaviour of natural mean value quantities.

The corresponding *deviation spectrum* — a finite collection of numbers generalizing the diffusion rate $\frac{2}{3}$ in the windtree model, can be found studying the renormalized dynamical system: the *Teichmüller geodesic flow* acting on the moduli space of quadratic differentials. The fact that one can compute (or estimate) the corresponding numbers comes from a beautiful interplay:

1. Dynamically, the moduli space of quadratic differentials pretends to be a homogeneous space: Eskin–Mirzakhani-Mohammadi have recently proved certain striking rigidity results (specific for homogeneous case).
2. Hodge theory provides rich geometric structure relating Lyapunov exponents and characteristic numbers of holomorphic vector bundles over certain loci in the moduli space first noticed by Kontsevich (talk of Martin Möller).
3. Geometrically, “Masur–Veech” volumes of the moduli spaces can be expressed as sort of Hurwitz numbers first studied by Eskin–Okounkov (talk of Elise Goujard).

0. Model problem:
diffusion in a periodic
billiard

1. Teichmüller dynamics

- Diffeomorphisms of surfaces
 - Pseudo-Anosov diffeomorphisms
 - Space of lattices
 - Moduli space of tori
 - Very flat surface of genus 2
 - Group action
 - Masur—Veech
- Theorem: an illustration
- Idea of renormalization

2. Translation surfaces
as quadratic differentials

3. Renormalization and
deviation spectrum

2016. State of the art

∞ . Challenges and
open directions

1. Teichmüller dynamics (following ideas of B. Thurston)

Diffeomorphisms of surfaces

Observation 1. *Surfaces can wrap around themselves.*

Cut a torus along a horizontal circle.

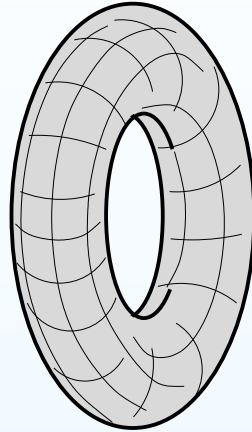

Diffeomorphisms of surfaces

Observation 1. *Surfaces can wrap around themselves.*

Dehn twist twists progressively horizontal circles up to a complete turn on the opposite boundary component of the cylinder and then identifies the components.

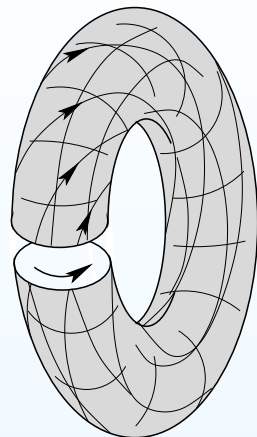

Diffeomorphisms of surfaces

Observation 1. *Surfaces can wrap around themselves.*

Dehn twist twists progressively horizontal circles up to a complete turn on the opposite boundary component of the cylinder and then identifies the components.

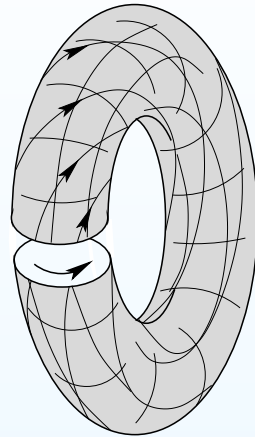

$$\begin{array}{ccc} \mathbb{R}^2 & \xrightarrow{\hat{f}_h} & \mathbb{R}^2 \\ \downarrow & & \downarrow \\ \mathbb{R}^2/\mathbb{Z}^2 = \mathbb{T}^2 & \xrightarrow{f_h} & \mathbb{T}^2 = \mathbb{R}^2/\mathbb{Z}^2 \end{array}$$

Dehn twist corresponds to the linear map $\hat{f}_h : \mathbb{R}^2 \rightarrow \mathbb{R}^2$ with the matrix $\begin{pmatrix} 1 & 1 \\ 0 & 1 \end{pmatrix}$.

Diffeomorphisms of surfaces

Observation 1. Surfaces can wrap around themselves.

Dehn twist twists progressively horizontal circles up to a complete turn on the opposite boundary component of the cylinder and then identifies the components.

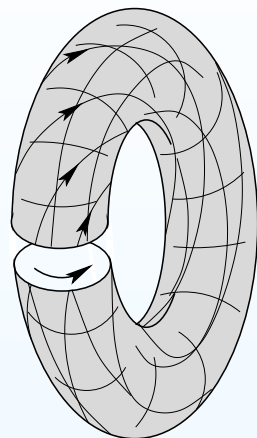

$$\begin{array}{ccc}
 \mathbb{R}^2 & \xrightarrow{\hat{f}_h} & \mathbb{R}^2 \\
 \downarrow & & \downarrow \\
 \mathbb{R}^2/\mathbb{Z}^2 = \mathbb{T}^2 & \xrightarrow{f_h} & \mathbb{T}^2 = \mathbb{R}^2/\mathbb{Z}^2
 \end{array}$$

Dehn twist corresponds to the linear map $\hat{f}_h : \mathbb{R}^2 \rightarrow \mathbb{R}^2$ with the matrix $\begin{pmatrix} 1 & 1 \\ 0 & 1 \end{pmatrix}$.

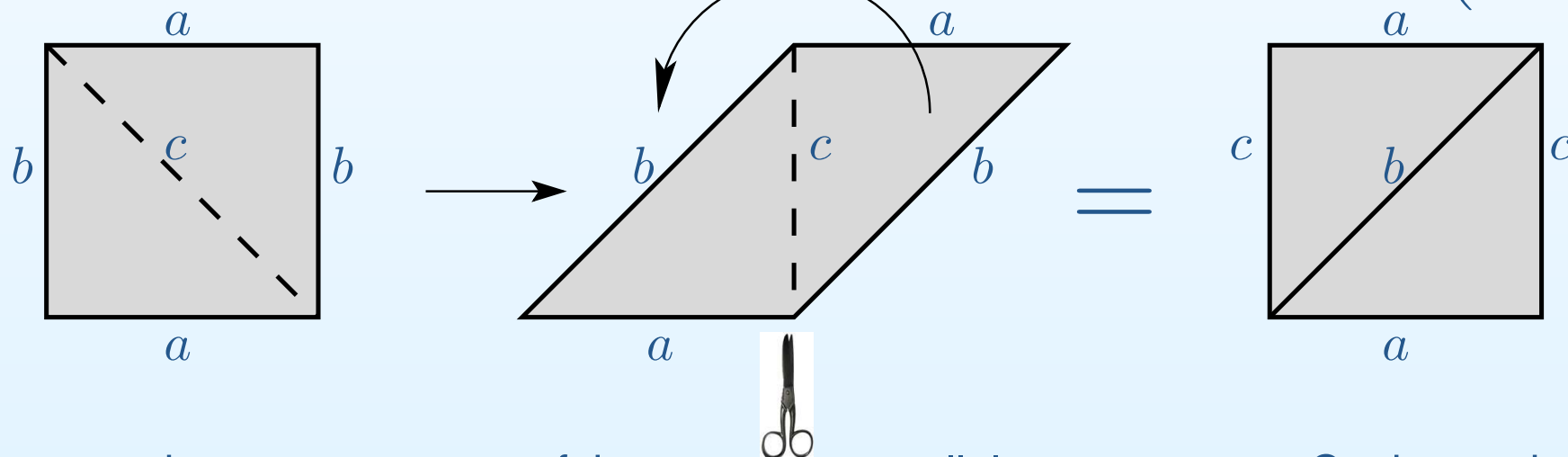

It maps the square pattern of the torus to a parallelogram pattern. Cutting and pasting appropriately we can transform the new pattern to the initial square.

Diffeomorphisms of surfaces

Observation 1. *Surfaces can wrap around themselves.*

Dehn twist twists progressively horizontal circles up to a complete turn on the opposite boundary component of the cylinder and then identifies the components.

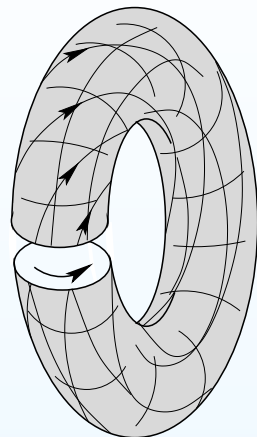

$$\begin{array}{ccc}
 \mathbb{R}^2 & \xrightarrow{\hat{f}_h} & \mathbb{R}^2 \\
 \downarrow & & \downarrow \\
 \mathbb{R}^2/\mathbb{Z}^2 = \mathbb{T}^2 & \xrightarrow{f_h} & \mathbb{T}^2 = \mathbb{R}^2/\mathbb{Z}^2
 \end{array}$$

Dehn twist corresponds to the linear map $\hat{f}_h : \mathbb{R}^2 \rightarrow \mathbb{R}^2$ with the matrix $\begin{pmatrix} 1 & 1 \\ 0 & 1 \end{pmatrix}$.

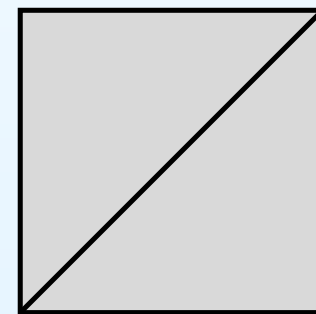
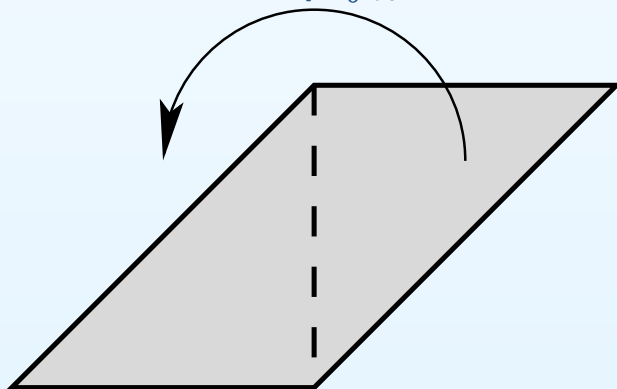
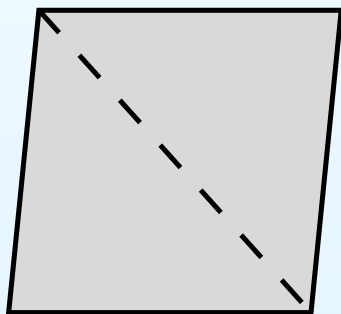

Changing the slope of the parallelogram pattern progressively we get a *closed path* in the space of flat tori.

Diffeomorphisms of surfaces

Observation 1. *Surfaces can wrap around themselves.*

Dehn twist twists progressively horizontal circles up to a complete turn on the opposite boundary component of the cylinder and then identifies the components.

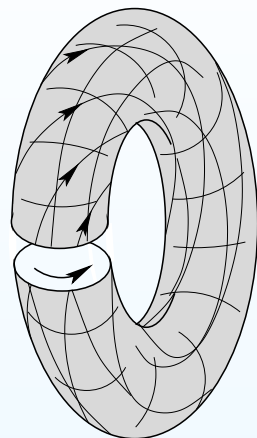

$$\begin{array}{ccc}
 \mathbb{R}^2 & \xrightarrow{\hat{f}_h} & \mathbb{R}^2 \\
 \downarrow & & \downarrow \\
 \mathbb{R}^2/\mathbb{Z}^2 = \mathbb{T}^2 & \xrightarrow{f_h} & \mathbb{T}^2 = \mathbb{R}^2/\mathbb{Z}^2
 \end{array}$$

Dehn twist corresponds to the linear map $\hat{f}_h : \mathbb{R}^2 \rightarrow \mathbb{R}^2$ with the matrix $\begin{pmatrix} 1 & 1 \\ 0 & 1 \end{pmatrix}$.

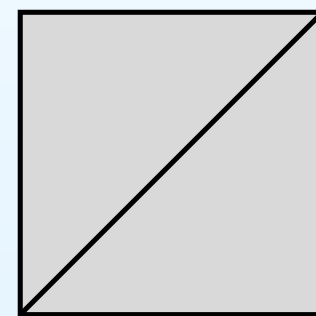
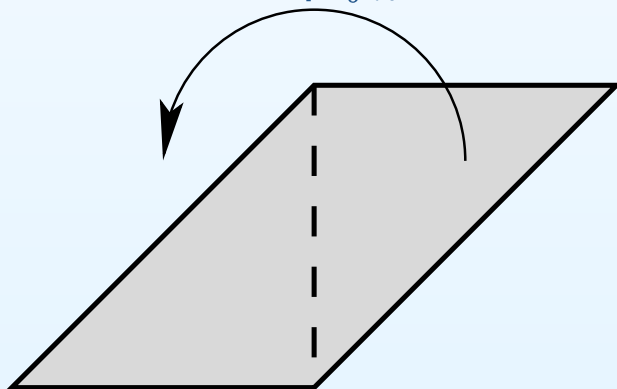
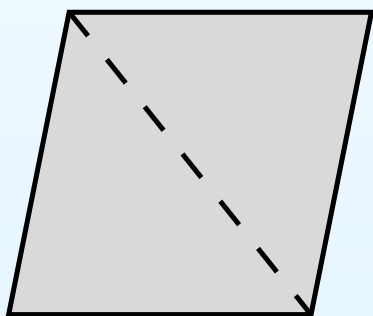

Changing the slope of the parallelogram pattern progressively we get a *closed path* in the space of flat tori.

Diffeomorphisms of surfaces

Observation 1. *Surfaces can wrap around themselves.*

Dehn twist twists progressively horizontal circles up to a complete turn on the opposite boundary component of the cylinder and then identifies the components.

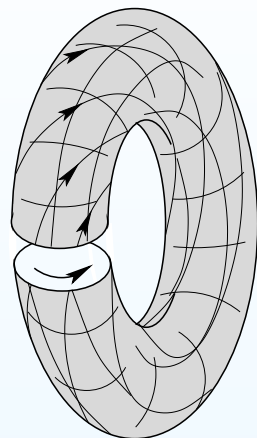

$$\begin{array}{ccc}
 \mathbb{R}^2 & \xrightarrow{\hat{f}_h} & \mathbb{R}^2 \\
 \downarrow & & \downarrow \\
 \mathbb{R}^2/\mathbb{Z}^2 = \mathbb{T}^2 & \xrightarrow{f_h} & \mathbb{T}^2 = \mathbb{R}^2/\mathbb{Z}^2
 \end{array}$$

Dehn twist corresponds to the linear map $\hat{f}_h : \mathbb{R}^2 \rightarrow \mathbb{R}^2$ with the matrix $\begin{pmatrix} 1 & 1 \\ 0 & 1 \end{pmatrix}$.

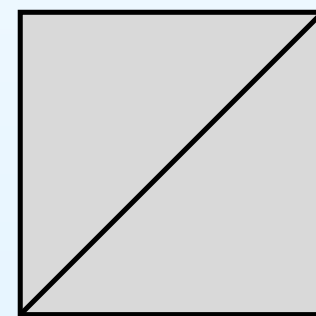
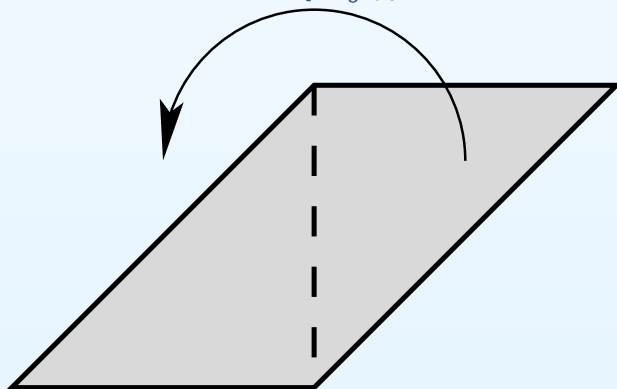
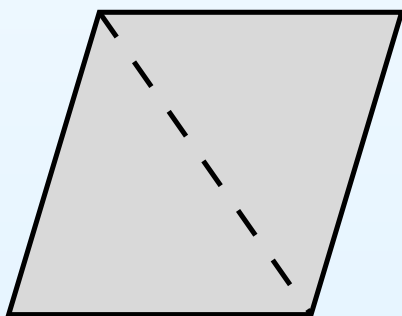

Changing the slope of the parallelogram pattern progressively we get a *closed path* in the space of flat tori.

Diffeomorphisms of surfaces

Observation 1. *Surfaces can wrap around themselves.*

Dehn twist twists progressively horizontal circles up to a complete turn on the opposite boundary component of the cylinder and then identifies the components.

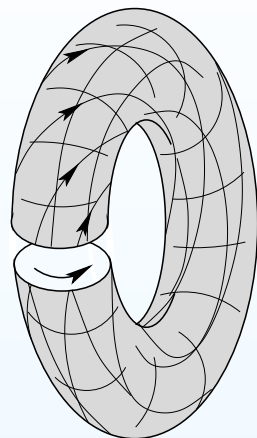

$$\begin{array}{ccc}
 \mathbb{R}^2 & \xrightarrow{\hat{f}_h} & \mathbb{R}^2 \\
 \downarrow & & \downarrow \\
 \mathbb{R}^2/\mathbb{Z}^2 = \mathbb{T}^2 & \xrightarrow{f_h} & \mathbb{T}^2 = \mathbb{R}^2/\mathbb{Z}^2
 \end{array}$$

Dehn twist corresponds to the linear map $\hat{f}_h : \mathbb{R}^2 \rightarrow \mathbb{R}^2$ with the matrix $\begin{pmatrix} 1 & 1 \\ 0 & 1 \end{pmatrix}$.

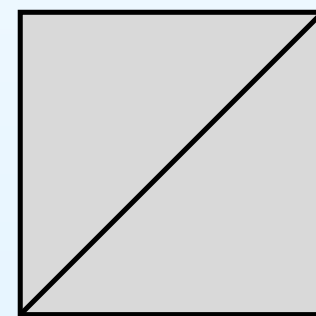
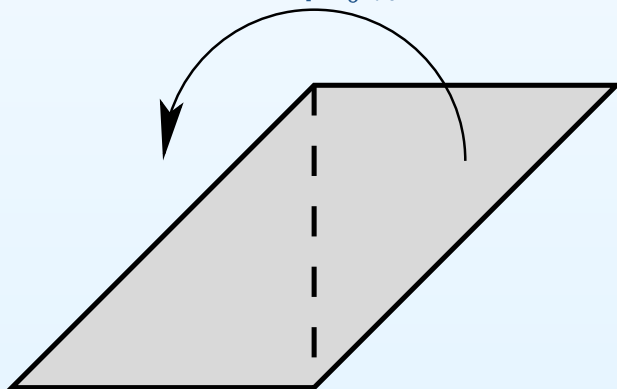
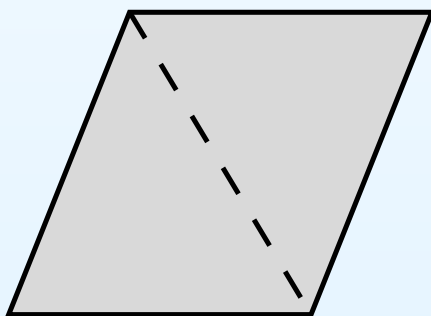

Changing the slope of the parallelogram pattern progressively we get a *closed path* in the space of flat tori.

Diffeomorphisms of surfaces

Observation 1. *Surfaces can wrap around themselves.*

Dehn twist twists progressively horizontal circles up to a complete turn on the opposite boundary component of the cylinder and then identifies the components.

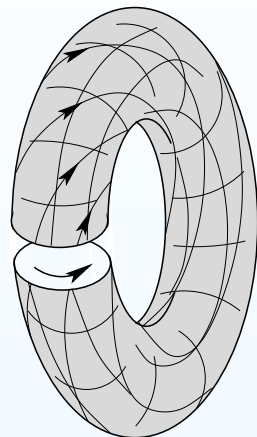

$$\begin{array}{ccc}
 \mathbb{R}^2 & \xrightarrow{\hat{f}_h} & \mathbb{R}^2 \\
 \downarrow & & \downarrow \\
 \mathbb{R}^2/\mathbb{Z}^2 = \mathbb{T}^2 & \xrightarrow{f_h} & \mathbb{T}^2 = \mathbb{R}^2/\mathbb{Z}^2
 \end{array}$$

Dehn twist corresponds to the linear map $\hat{f}_h : \mathbb{R}^2 \rightarrow \mathbb{R}^2$ with the matrix $\begin{pmatrix} 1 & 1 \\ 0 & 1 \end{pmatrix}$.

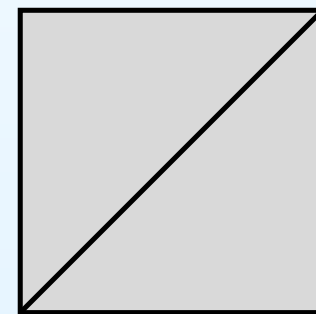
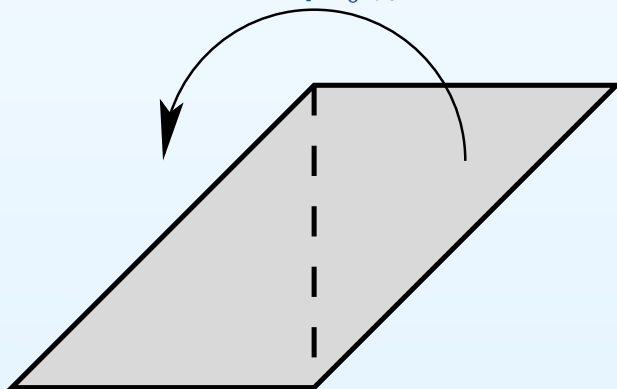
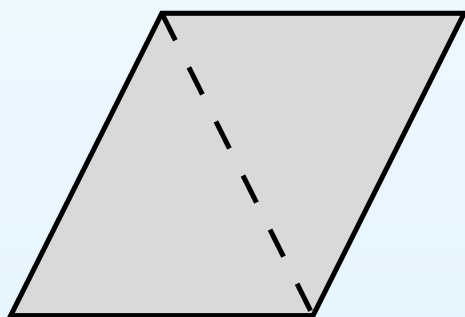

Changing the slope of the parallelogram pattern progressively we get a *closed path* in the space of flat tori.

Diffeomorphisms of surfaces

Observation 1. *Surfaces can wrap around themselves.*

Dehn twist twists progressively horizontal circles up to a complete turn on the opposite boundary component of the cylinder and then identifies the components.

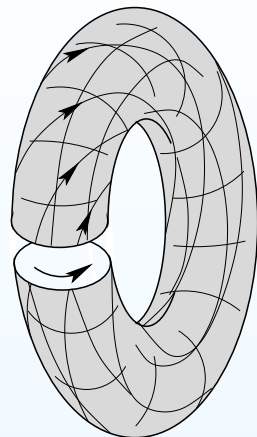

$$\begin{array}{ccc}
 \mathbb{R}^2 & \xrightarrow{\hat{f}_h} & \mathbb{R}^2 \\
 \downarrow & & \downarrow \\
 \mathbb{R}^2/\mathbb{Z}^2 = \mathbb{T}^2 & \xrightarrow{f_h} & \mathbb{T}^2 = \mathbb{R}^2/\mathbb{Z}^2
 \end{array}$$

Dehn twist corresponds to the linear map $\hat{f}_h : \mathbb{R}^2 \rightarrow \mathbb{R}^2$ with the matrix $\begin{pmatrix} 1 & 1 \\ 0 & 1 \end{pmatrix}$.

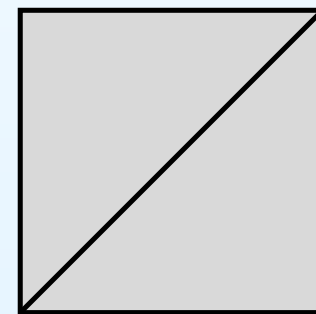
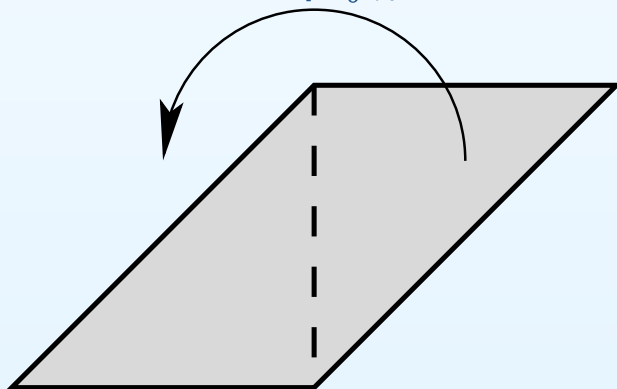
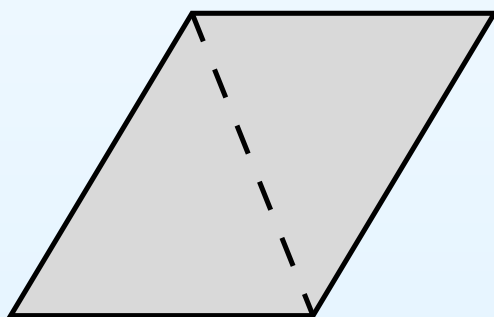

Changing the slope of the parallelogram pattern progressively we get a *closed path* in the space of flat tori.

Diffeomorphisms of surfaces

Observation 1. *Surfaces can wrap around themselves.*

Dehn twist twists progressively horizontal circles up to a complete turn on the opposite boundary component of the cylinder and then identifies the components.

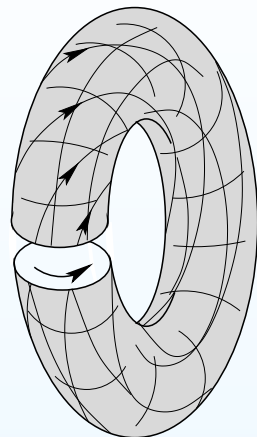

$$\begin{array}{ccc}
 \mathbb{R}^2 & \xrightarrow{\hat{f}_h} & \mathbb{R}^2 \\
 \downarrow & & \downarrow \\
 \mathbb{R}^2/\mathbb{Z}^2 = \mathbb{T}^2 & \xrightarrow{f_h} & \mathbb{T}^2 = \mathbb{R}^2/\mathbb{Z}^2
 \end{array}$$

Dehn twist corresponds to the linear map $\hat{f}_h : \mathbb{R}^2 \rightarrow \mathbb{R}^2$ with the matrix $\begin{pmatrix} 1 & 1 \\ 0 & 1 \end{pmatrix}$.

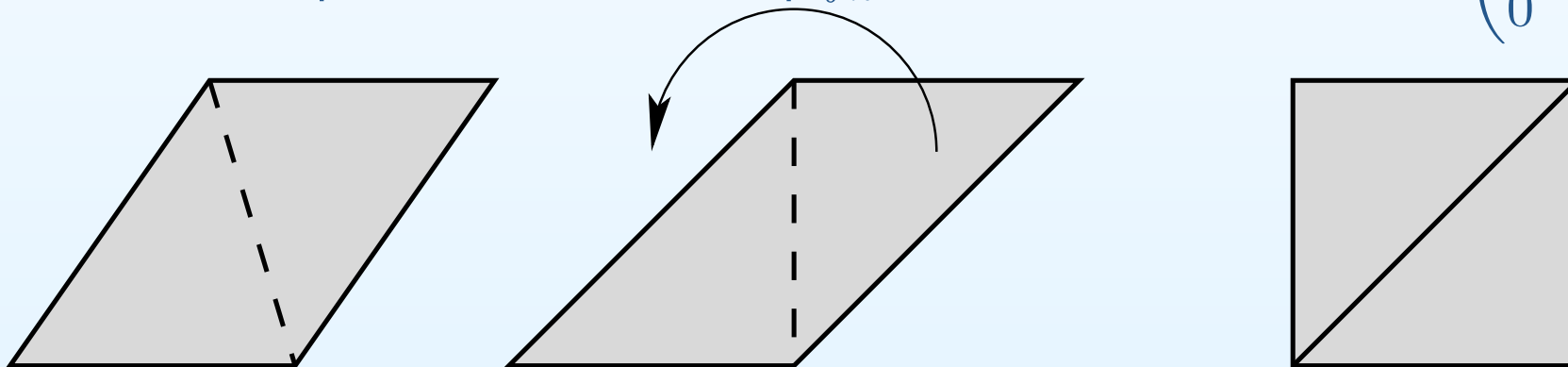

Changing the slope of the parallelogram pattern progressively we get a *closed path* in the space of flat tori.

Diffeomorphisms of surfaces

Observation 1. *Surfaces can wrap around themselves.*

Dehn twist twists progressively horizontal circles up to a complete turn on the opposite boundary component of the cylinder and then identifies the components.

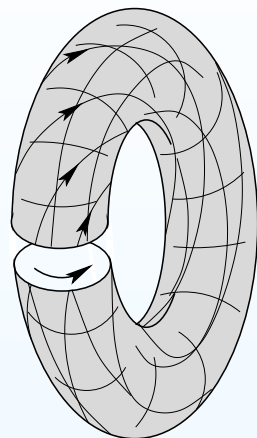

$$\begin{array}{ccc}
 \mathbb{R}^2 & \xrightarrow{\hat{f}_h} & \mathbb{R}^2 \\
 \downarrow & & \downarrow \\
 \mathbb{R}^2/\mathbb{Z}^2 = \mathbb{T}^2 & \xrightarrow{f_h} & \mathbb{T}^2 = \mathbb{R}^2/\mathbb{Z}^2
 \end{array}$$

Dehn twist corresponds to the linear map $\hat{f}_h : \mathbb{R}^2 \rightarrow \mathbb{R}^2$ with the matrix $\begin{pmatrix} 1 & 1 \\ 0 & 1 \end{pmatrix}$.

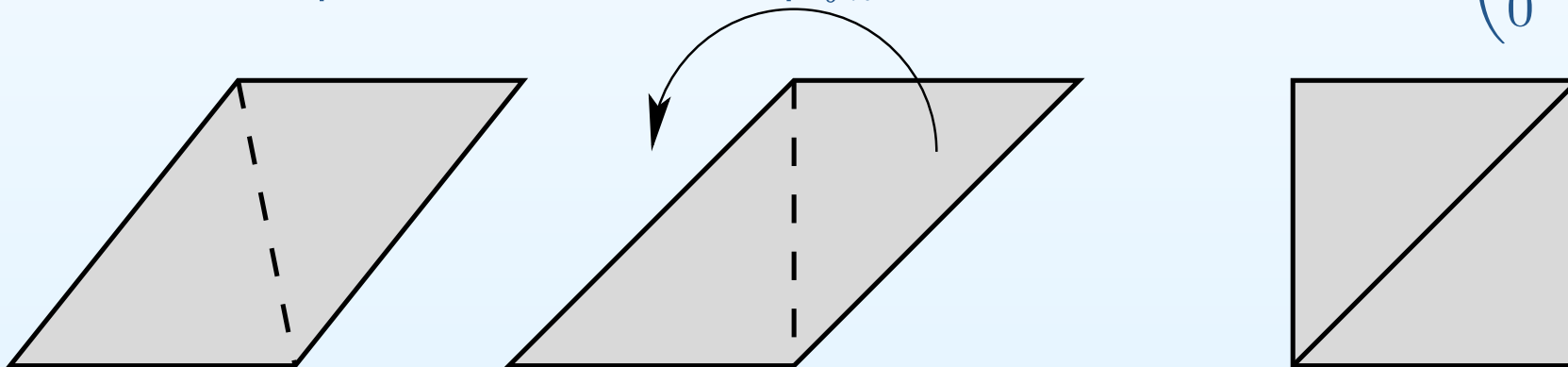

Changing the slope of the parallelogram pattern progressively we get a *closed path* in the space of flat tori.

Diffeomorphisms of surfaces

Observation 1. *Surfaces can wrap around themselves.*

Dehn twist twists progressively horizontal circles up to a complete turn on the opposite boundary component of the cylinder and then identifies the components.

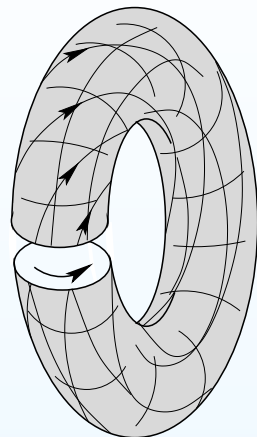

$$\begin{array}{ccc}
 \mathbb{R}^2 & \xrightarrow{\hat{f}_h} & \mathbb{R}^2 \\
 \downarrow & & \downarrow \\
 \mathbb{R}^2/\mathbb{Z}^2 = \mathbb{T}^2 & \xrightarrow{f_h} & \mathbb{T}^2 = \mathbb{R}^2/\mathbb{Z}^2
 \end{array}$$

Dehn twist corresponds to the linear map $\hat{f}_h : \mathbb{R}^2 \rightarrow \mathbb{R}^2$ with the matrix $\begin{pmatrix} 1 & 1 \\ 0 & 1 \end{pmatrix}$.

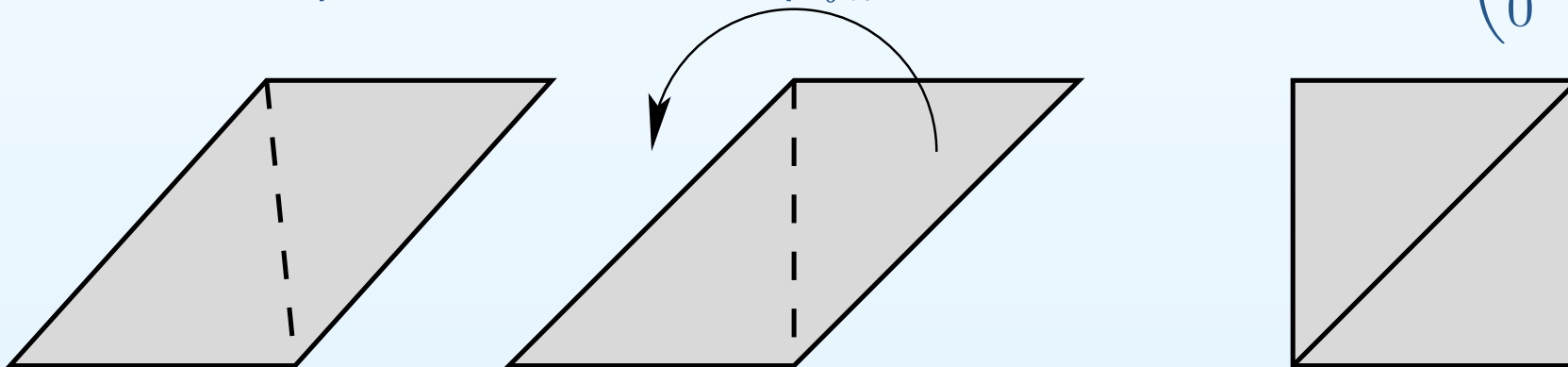

Changing the slope of the parallelogram pattern progressively we get a *closed path* in the space of flat tori.

Diffeomorphisms of surfaces

Observation 1. *Surfaces can wrap around themselves.*

Dehn twist twists progressively horizontal circles up to a complete turn on the opposite boundary component of the cylinder and then identifies the components.

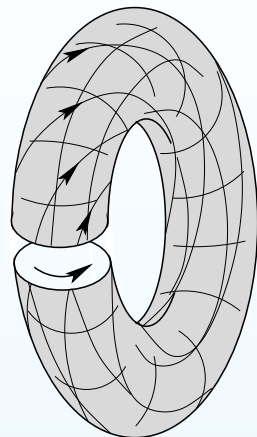

$$\begin{array}{ccc}
 \mathbb{R}^2 & \xrightarrow{\hat{f}_h} & \mathbb{R}^2 \\
 \downarrow & & \downarrow \\
 \mathbb{R}^2/\mathbb{Z}^2 = \mathbb{T}^2 & \xrightarrow{f_h} & \mathbb{T}^2 = \mathbb{R}^2/\mathbb{Z}^2
 \end{array}$$

Dehn twist corresponds to the linear map $\hat{f}_h : \mathbb{R}^2 \rightarrow \mathbb{R}^2$ with the matrix $\begin{pmatrix} 1 & 1 \\ 0 & 1 \end{pmatrix}$.

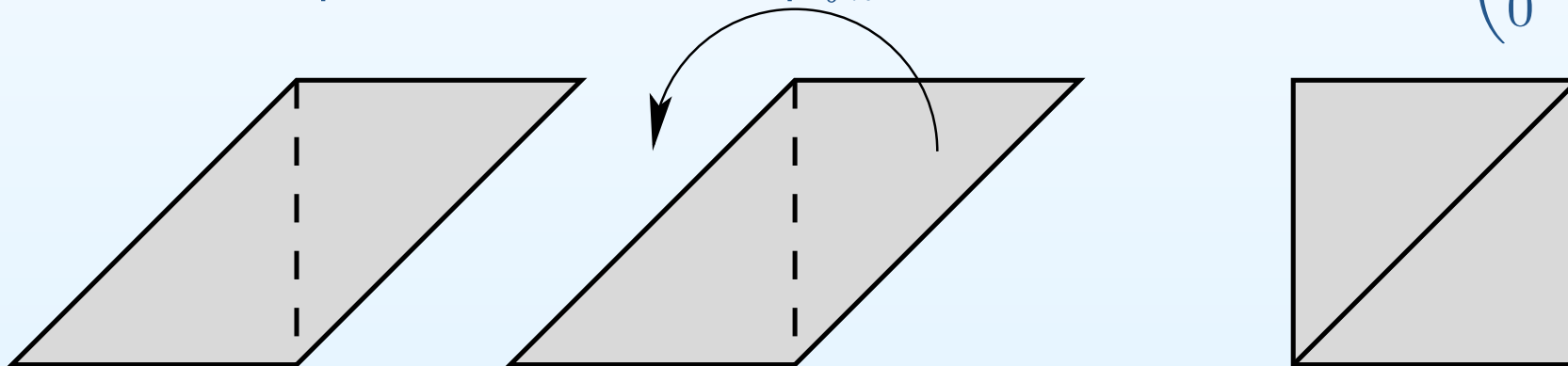

Changing the slope of the parallelogram pattern progressively we get a *closed path* in the space of flat tori.

Diffeomorphisms of surfaces

Observation 1. Surfaces can wrap around themselves.

Dehn twist twists progressively horizontal circles up to a complete turn on the opposite boundary component of the cylinder and then identifies the components.

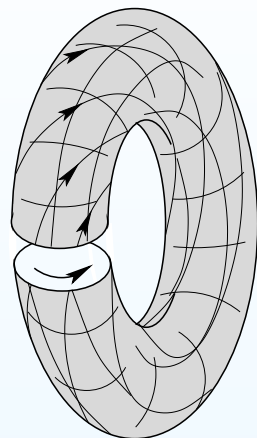

$$\begin{array}{ccc}
 \mathbb{R}^2 & \xrightarrow{\hat{f}_h} & \mathbb{R}^2 \\
 \downarrow & & \downarrow \\
 \mathbb{R}^2/\mathbb{Z}^2 = \mathbb{T}^2 & \xrightarrow{f_h} & \mathbb{T}^2 = \mathbb{R}^2/\mathbb{Z}^2
 \end{array}$$

Dehn twist corresponds to the linear map $\hat{f}_h : \mathbb{R}^2 \rightarrow \mathbb{R}^2$ with the matrix $\begin{pmatrix} 1 & 1 \\ 0 & 1 \end{pmatrix}$.

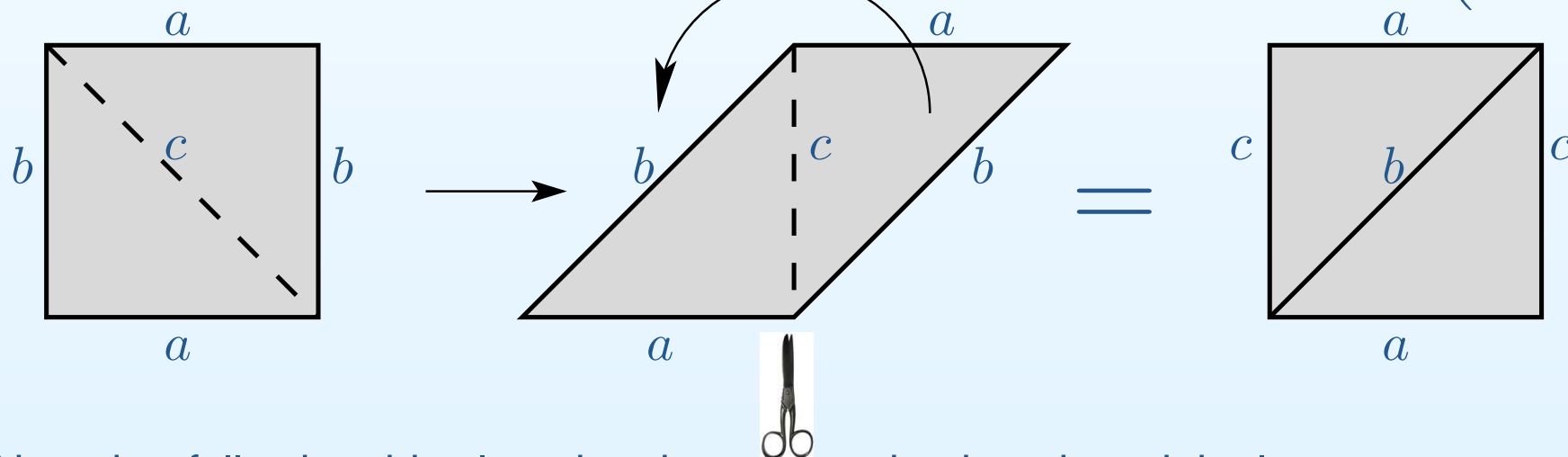

Note that following this closed path we come back to the original square torus having twisted the homology!

Pseudo-Anosov diffeomorphisms

Consider a composition
of two Dehn twists

$$g = f_v \circ f_h =$$

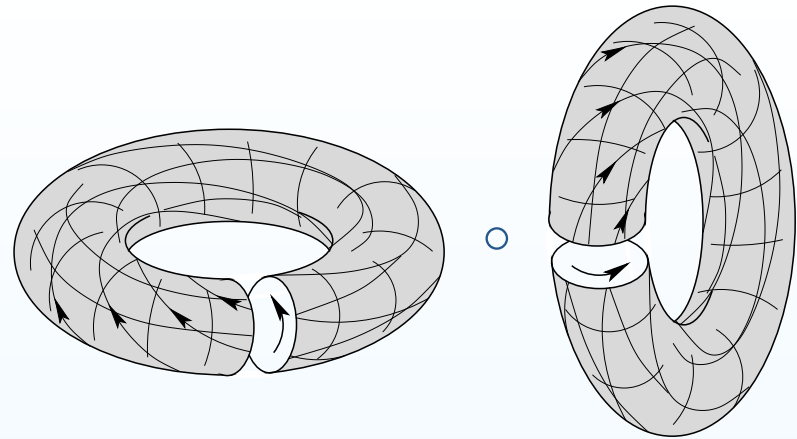

Pseudo-Anosov diffeomorphisms

Consider a composition
of two Dehn twists

$$g = f_v \circ f_h =$$

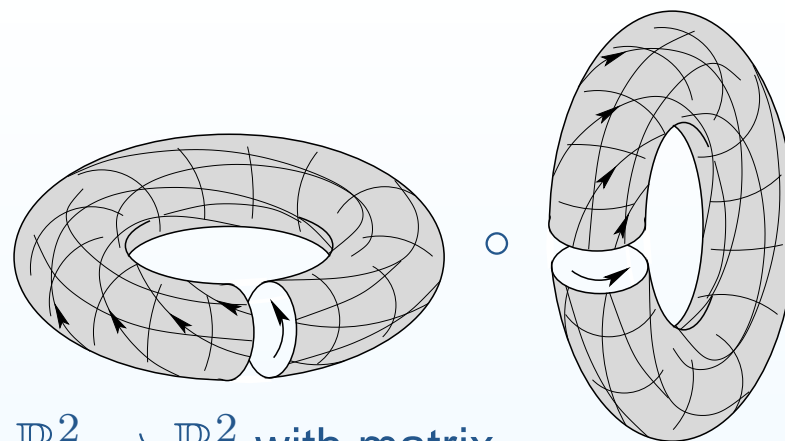

It corresponds to the integer linear map $\hat{g} : \mathbb{R}^2 \rightarrow \mathbb{R}^2$ with matrix

$A = \begin{pmatrix} 1 & 1 \\ 1 & 2 \end{pmatrix} = \begin{pmatrix} 1 & 0 \\ 1 & 1 \end{pmatrix} \cdot \begin{pmatrix} 1 & 1 \\ 0 & 1 \end{pmatrix}$. Cutting and pasting appropriately the image parallelogram pattern we can check by hands that we can transform the new pattern to the initial square one.

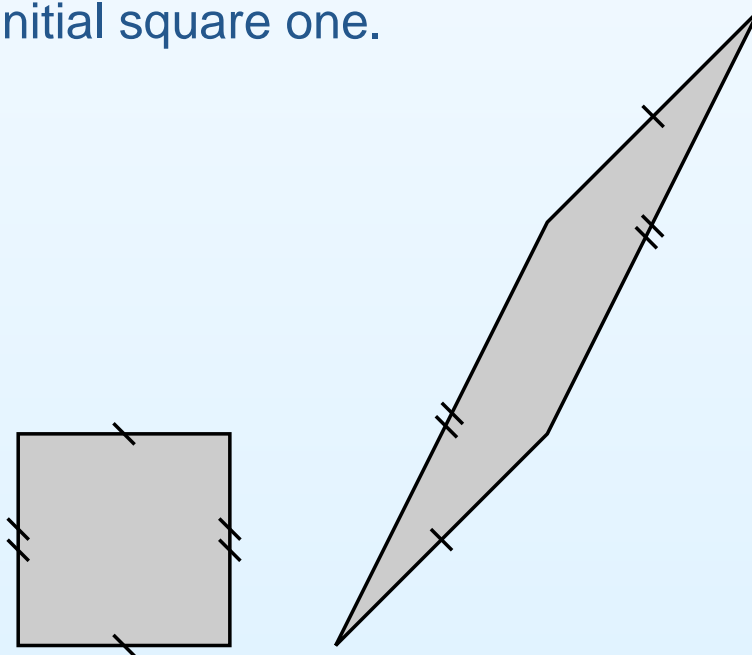

Pseudo-Anosov diffeomorphisms

Consider a composition
of two Dehn twists

$$g = f_v \circ f_h =$$

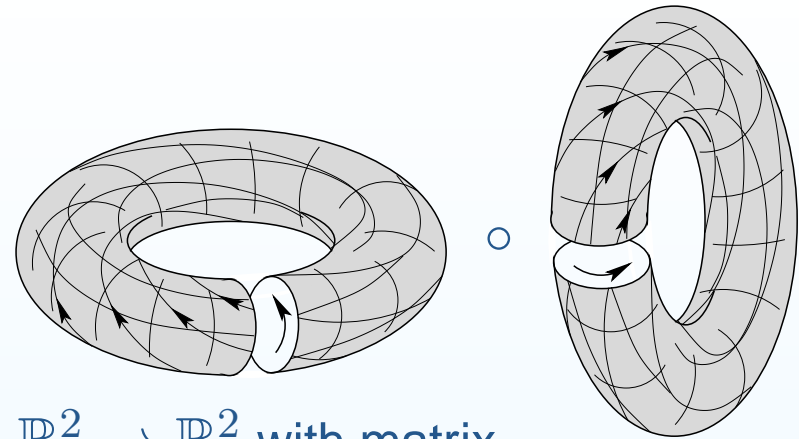

It corresponds to the integer linear map $\hat{g} : \mathbb{R}^2 \rightarrow \mathbb{R}^2$ with matrix

$$A = \begin{pmatrix} 1 & 1 \\ 1 & 2 \end{pmatrix} = \begin{pmatrix} 1 & 0 \\ 1 & 1 \end{pmatrix} \cdot \begin{pmatrix} 1 & 1 \\ 0 & 1 \end{pmatrix}.$$

Cutting and pasting appropriately the image parallelogram pattern we can check by hands that we can transform the new pattern to the initial square one.

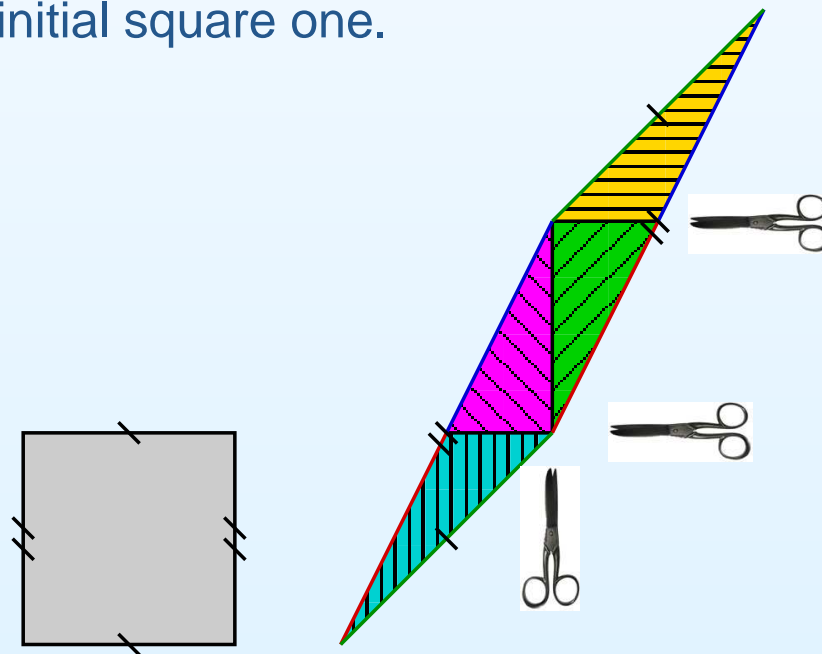

Pseudo-Anosov diffeomorphisms

Consider a composition
of two Dehn twists

$$g = f_v \circ f_h =$$

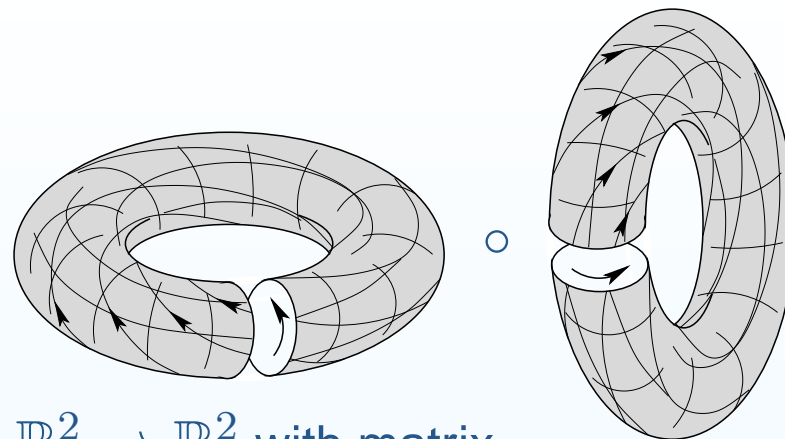

It corresponds to the integer linear map $\hat{g} : \mathbb{R}^2 \rightarrow \mathbb{R}^2$ with matrix

$A = \begin{pmatrix} 1 & 1 \\ 1 & 2 \end{pmatrix} = \begin{pmatrix} 1 & 0 \\ 1 & 1 \end{pmatrix} \cdot \begin{pmatrix} 1 & 1 \\ 0 & 1 \end{pmatrix}$. Cutting and pasting appropriately the image parallelogram pattern we can check by hands that we can transform the new pattern to the initial square one.

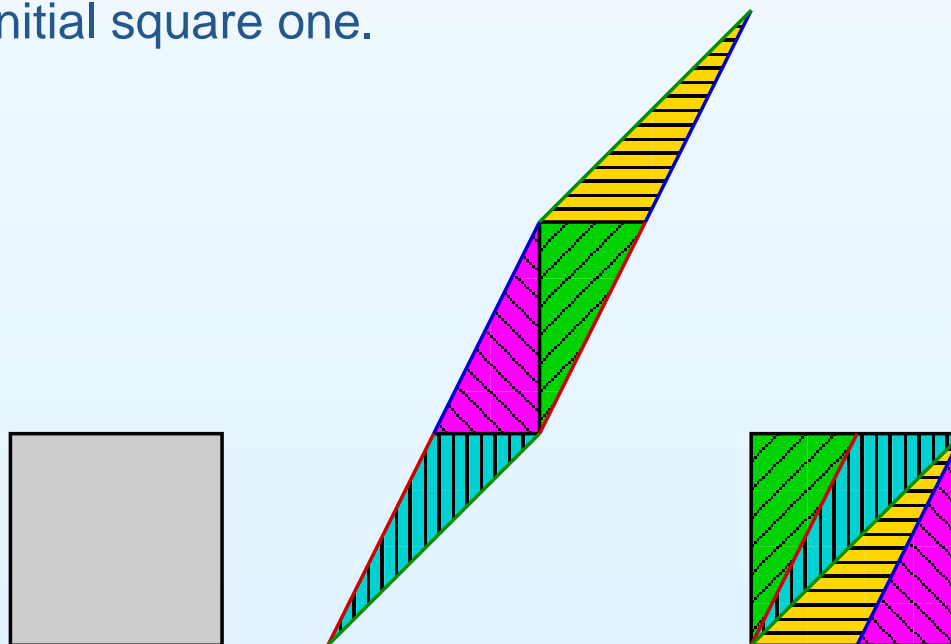

Pseudo-Anosov diffeomorphisms

Consider eigenvectors \vec{v}_u and \vec{v}_s of the linear transformation $A = \begin{pmatrix} 1 & 1 \\ 1 & 2 \end{pmatrix}$

with eigenvalues $\lambda = (3 + \sqrt{5})/2 \approx 2.6$ and $1/\lambda = (3 - \sqrt{5})/2 \approx 0.38$.

Consider two transversal foliations on the original torus in directions \vec{v}_u, \vec{v}_s . We have just proved that expanding our torus \mathbb{T}^2 by factor λ in direction \vec{v}_u and contracting it by the factor $1/\lambda$ in direction \vec{v}_s we get the original torus.

Definition. Surface automorphism homogeneously expanding in direction of one foliation and homogeneously contracting in direction of the transverse foliation is called a *pseudo-Anosov* diffeomorphism.

Consider a one-parameter family of flat tori obtained from the initial square torus by a continuous deformation expanding with a factor e^t in directions \vec{v}_u and contracting with a factor e^{-t} in direction \vec{v}_s . By construction such one-parameter family defines a closed curve in the space of flat tori: after the time $t_0 = \log \lambda_u$ it closes up and follows itself.

Observation 2. *Pseudo-Anosov diffeomorphisms define closed curves (actually, closed geodesics) in the moduli spaces of Riemann surfaces.*

Pseudo-Anosov diffeomorphisms

Consider eigenvectors \vec{v}_u and \vec{v}_s of the linear transformation $A = \begin{pmatrix} 1 & 1 \\ 1 & 2 \end{pmatrix}$

with eigenvalues $\lambda = (3 + \sqrt{5})/2 \approx 2.6$ and $1/\lambda = (3 - \sqrt{5})/2 \approx 0.38$.

Consider two transversal foliations on the original torus in directions \vec{v}_u, \vec{v}_s . We have just proved that expanding our torus \mathbb{T}^2 by factor λ in direction \vec{v}_u and contracting it by the factor $1/\lambda$ in direction \vec{v}_s we get the original torus.

Definition. Surface automorphism homogeneously expanding in direction of one foliation and homogeneously contracting in direction of the transverse foliation is called a *pseudo-Anosov* diffeomorphism.

Consider a one-parameter family of flat tori obtained from the initial square torus by a continuous deformation expanding with a factor e^t in directions \vec{v}_u and contracting with a factor e^{-t} in direction \vec{v}_s . By construction such one-parameter family defines a closed curve in the space of flat tori: after the time $t_0 = \log \lambda_u$ it closes up and follows itself.

Observation 2. *Pseudo-Anosov diffeomorphisms define closed curves (actually, closed geodesics) in the moduli spaces of Riemann surfaces.*

Pseudo-Anosov diffeomorphisms

Consider eigenvectors \vec{v}_u and \vec{v}_s of the linear transformation $A = \begin{pmatrix} 1 & 1 \\ 1 & 2 \end{pmatrix}$

with eigenvalues $\lambda = (3 + \sqrt{5})/2 \approx 2.6$ and $1/\lambda = (3 - \sqrt{5})/2 \approx 0.38$.

Consider two transversal foliations on the original torus in directions \vec{v}_u, \vec{v}_s . We have just proved that expanding our torus \mathbb{T}^2 by factor λ in direction \vec{v}_u and contracting it by the factor $1/\lambda$ in direction \vec{v}_s we get the original torus.

Definition. Surface automorphism homogeneously expanding in direction of one foliation and homogeneously contracting in direction of the transverse foliation is called a *pseudo-Anosov* diffeomorphism.

Consider a one-parameter family of flat tori obtained from the initial square torus by a continuous deformation expanding with a factor e^t in directions \vec{v}_u and contracting with a factor e^{-t} in direction \vec{v}_s . By construction such one-parameter family defines a closed curve in the space of flat tori: after the time $t_0 = \log \lambda_u$ it closes up and follows itself.

Observation 2. *Pseudo-Anosov diffeomorphisms define closed curves (actually, closed geodesics) in the moduli spaces of Riemann surfaces.*

Pseudo-Anosov diffeomorphisms

Consider eigenvectors \vec{v}_u and \vec{v}_s of the linear transformation $A = \begin{pmatrix} 1 & 1 \\ 1 & 2 \end{pmatrix}$

with eigenvalues $\lambda = (3 + \sqrt{5})/2 \approx 2.6$ and $1/\lambda = (3 - \sqrt{5})/2 \approx 0.38$.

Consider two transversal foliations on the original torus in directions \vec{v}_u, \vec{v}_s . We have just proved that expanding our torus \mathbb{T}^2 by factor λ in direction \vec{v}_u and contracting it by the factor $1/\lambda$ in direction \vec{v}_s we get the original torus.

Definition. Surface automorphism homogeneously expanding in direction of one foliation and homogeneously contracting in direction of the transverse foliation is called a *pseudo-Anosov* diffeomorphism.

Consider a one-parameter family of flat tori obtained from the initial square torus by a continuous deformation expanding with a factor e^t in directions \vec{v}_u and contracting with a factor e^{-t} in direction \vec{v}_s . By construction such one-parameter family defines a closed curve in the space of flat tori: after the time $t_0 = \log \lambda_u$ it closes up and follows itself.

Observation 2. *Pseudo-Anosov diffeomorphisms define closed curves (actually, closed geodesics) in the moduli spaces of Riemann surfaces.*

Space of lattices

- By a composition of homothety and rotation we can place the shortest vector of the lattice to the horizontal unit vector.

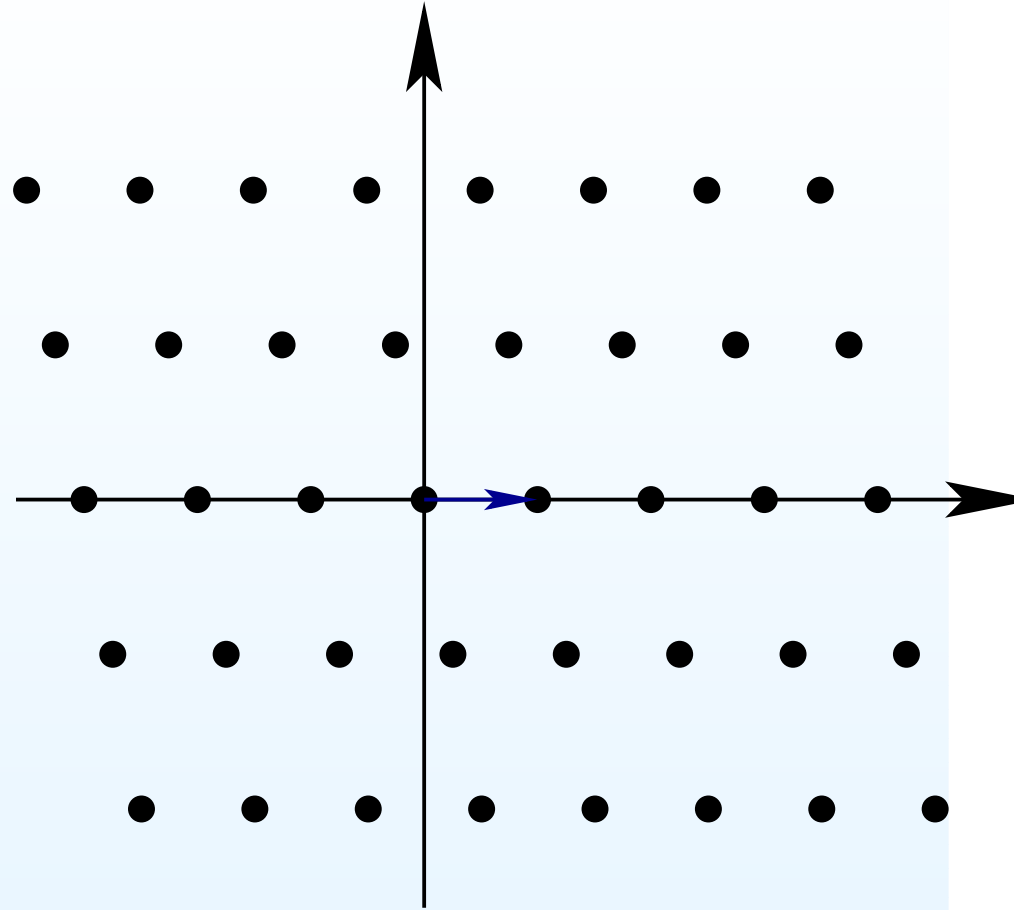

Space of lattices

- By a composition of homothety and rotation we can place the shortest vector of the lattice to the horizontal unit vector.
- Consider the lattice point closest to the origin and located in the upper half-plane.

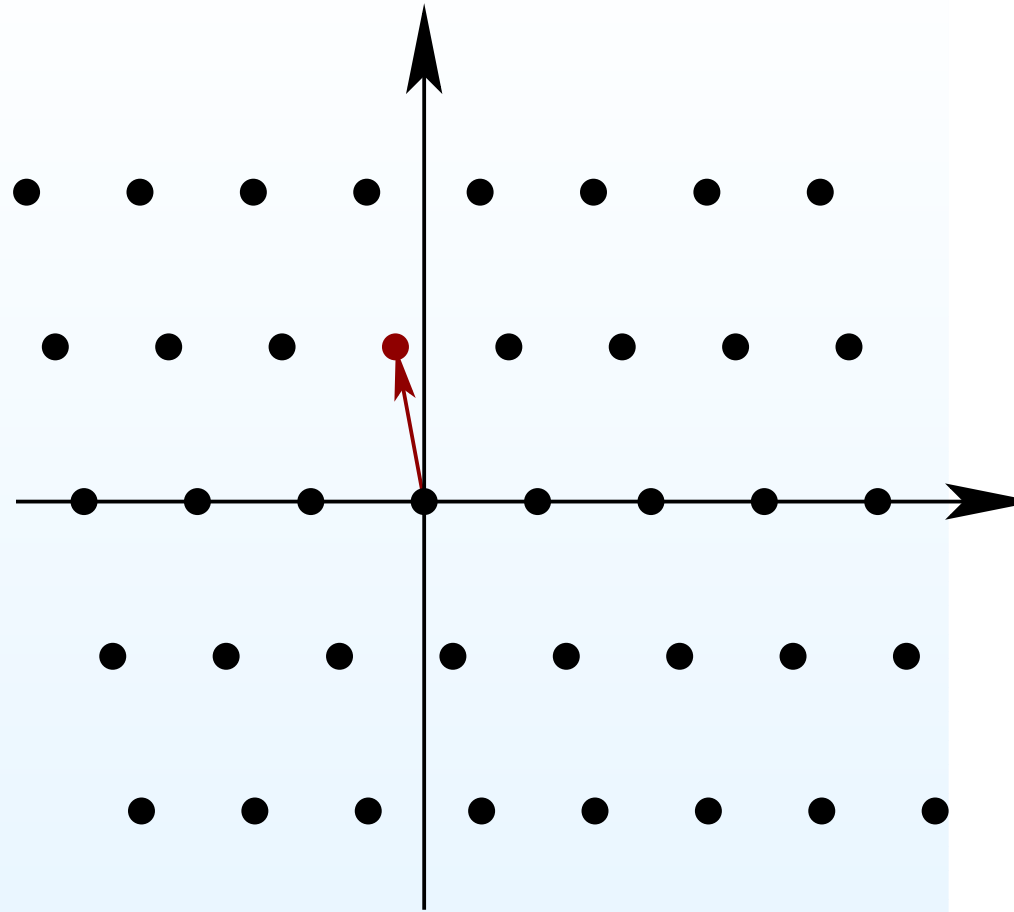

Space of lattices

- By a composition of homothety and rotation we can place the shortest vector of the lattice to the horizontal unit vector.
- Consider the lattice point closest to the origin and located in the upper half-plane.
- This point is located outside of the unit disc.

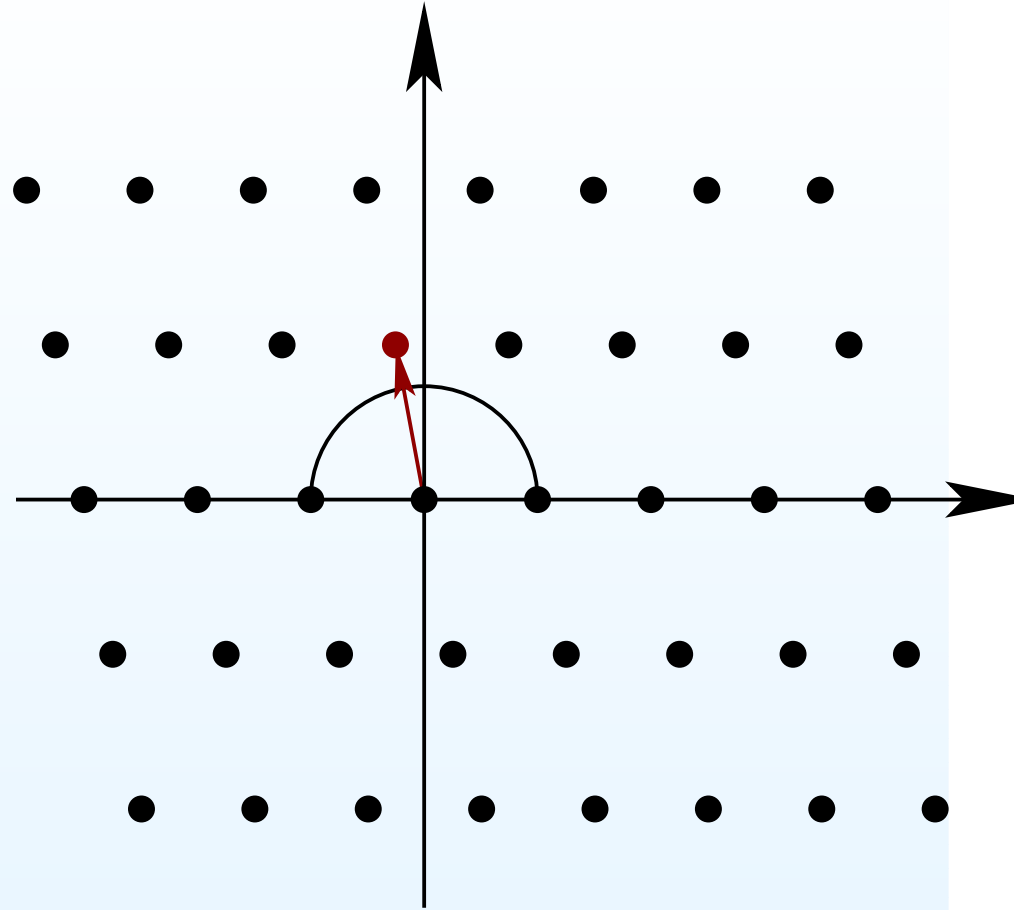

Space of lattices

- By a composition of homothety and rotation we can place the shortest vector of the lattice to the horizontal unit vector.
- Consider the lattice point closest to the origin and located in the upper half-plane.
- This point is located outside of the unit disc.
- It necessarily lives inside the strip $-1/2 \leq x \leq 1/2$.

We get a fundamental domain in the space of lattices, or, in other words, in the moduli space of flat tori.

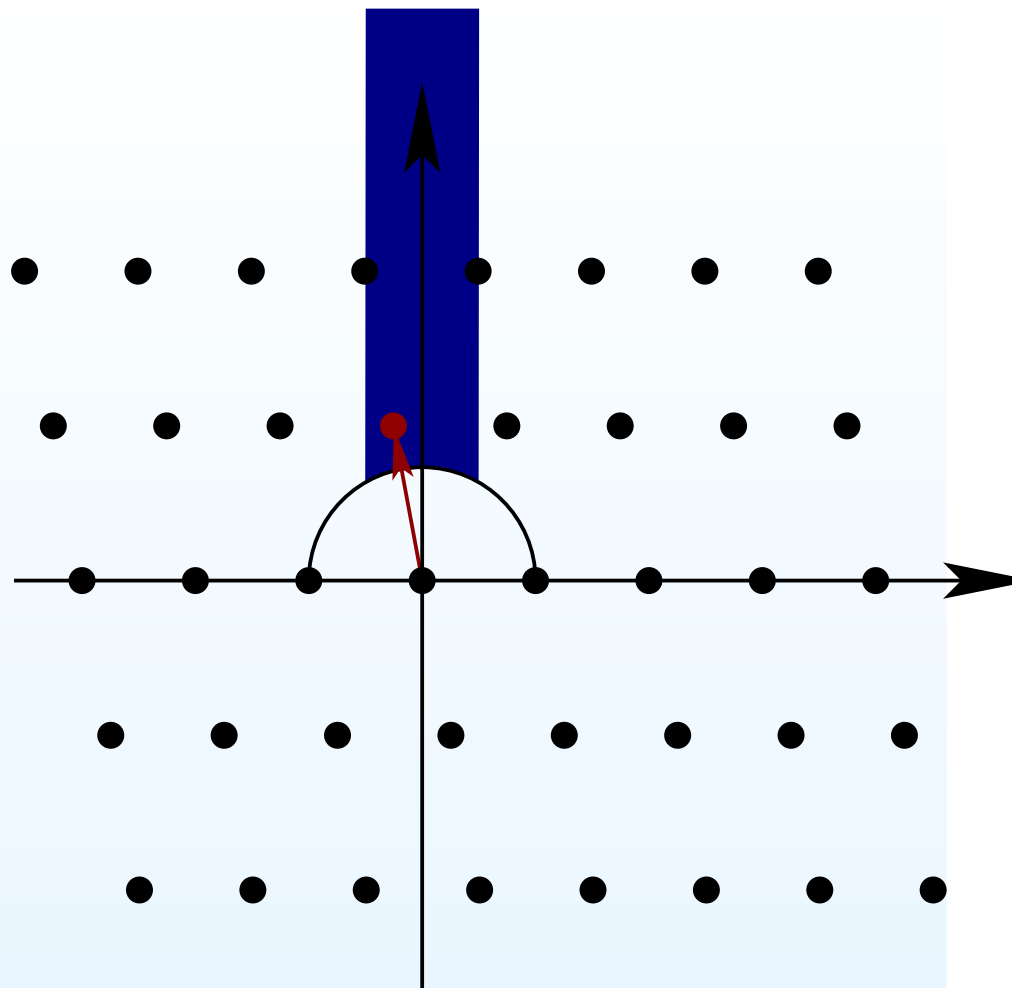

Moduli space of tori

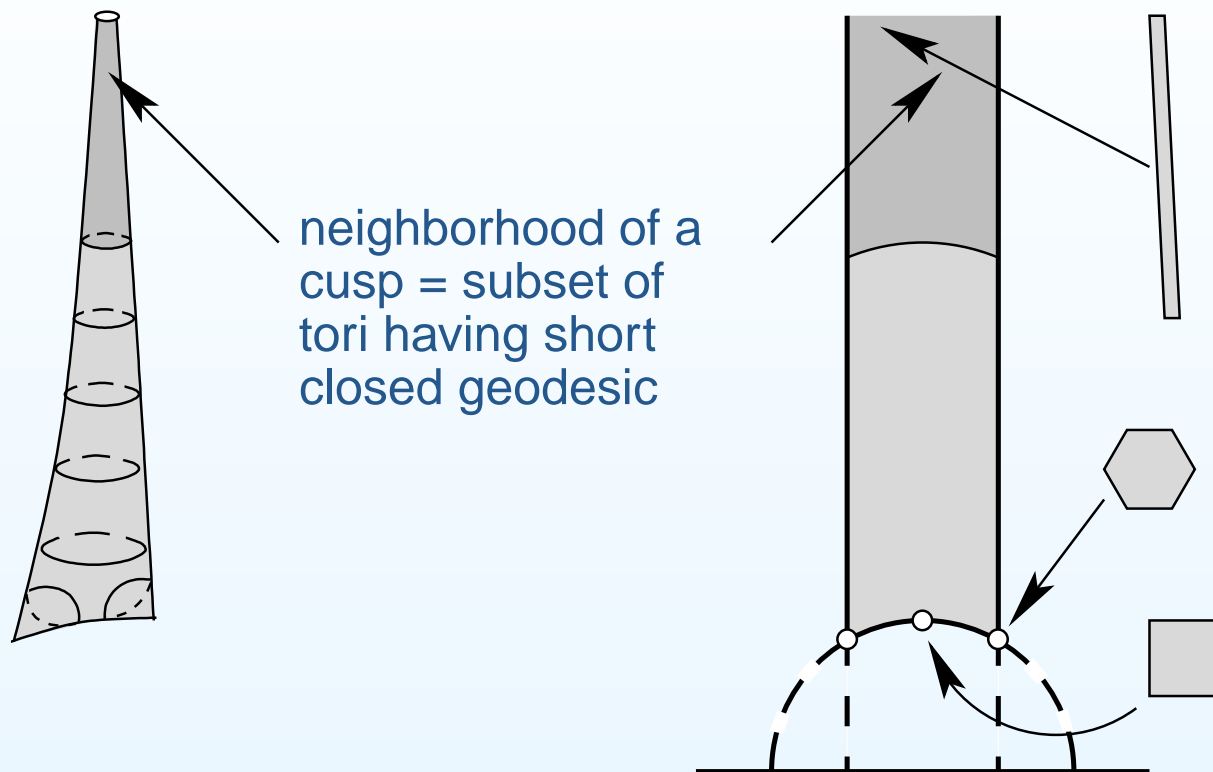

The corresponding modular surface is not compact: flat tori representing points, which are close to the cusp, are almost degenerate: they have a very short closed geodesic. It also has orbifold points corresponding to tori with extra symmetries.

Very flat surface of genus 2

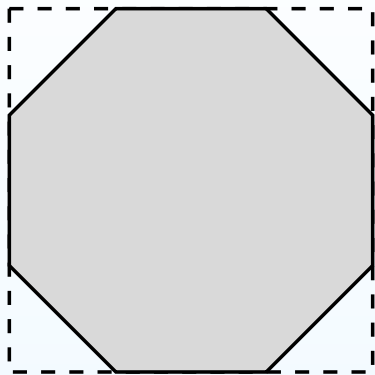

Identifying the opposite sides of a regular octagon we get a flat surface of genus two. All the vertices of the octagon are identified into a single conical singularity. We always consider such a flat surface endowed with a distinguished (say, vertical) direction. By construction, the holonomy of the flat metric is trivial. Thus, the vertical direction at a single point globally defines vertical and horizontal foliations.

Very flat surface of genus 2

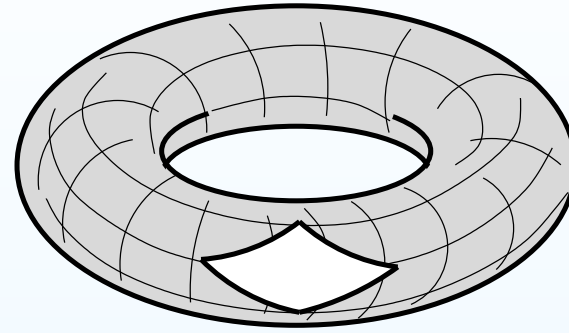
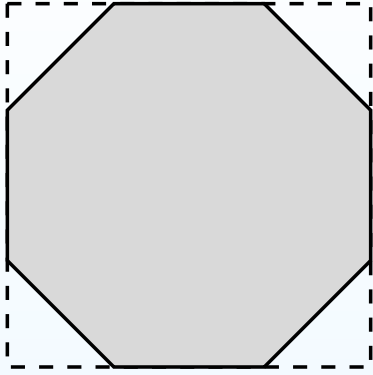

Identifying the opposite sides of a regular octagon we get a flat surface of genus two. All the vertices of the octagon are identified into a single conical singularity. We always consider such a flat surface endowed with a distinguished (say, vertical) direction. By construction, the holonomy of the flat metric is trivial. Thus, the vertical direction at a single point globally defines vertical and horizontal foliations.

Very flat surface of genus 2

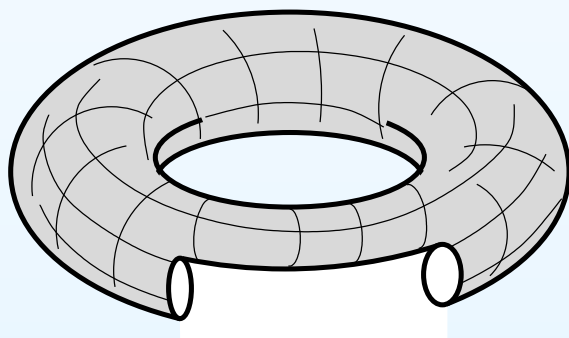
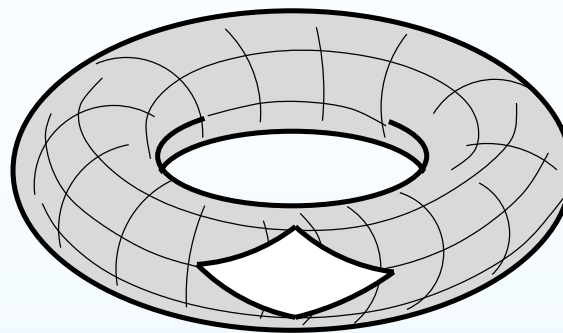
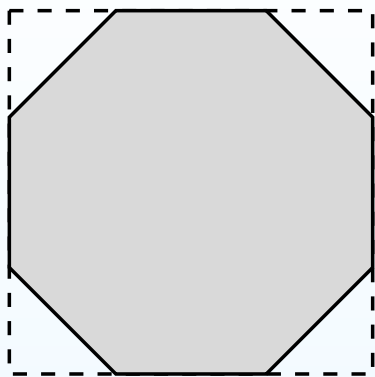

Identifying the opposite sides of a regular octagon we get a flat surface of genus two. All the vertices of the octagon are identified into a single conical singularity. We always consider such a flat surface endowed with a distinguished (say, vertical) direction. By construction, the holonomy of the flat metric is trivial. Thus, the vertical direction at a single point globally defines vertical and horizontal foliations.

Very flat surface of genus 2

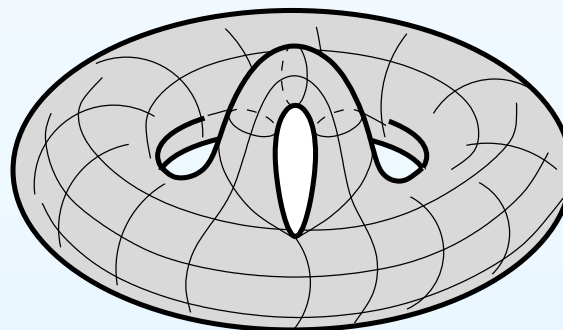
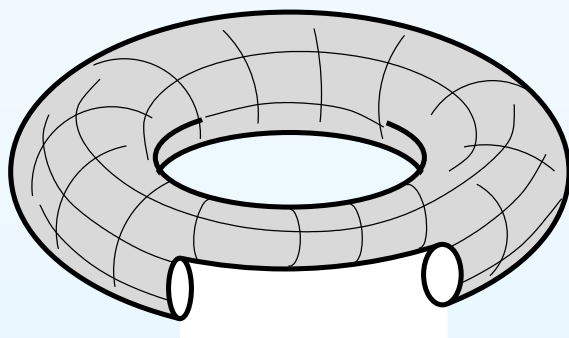
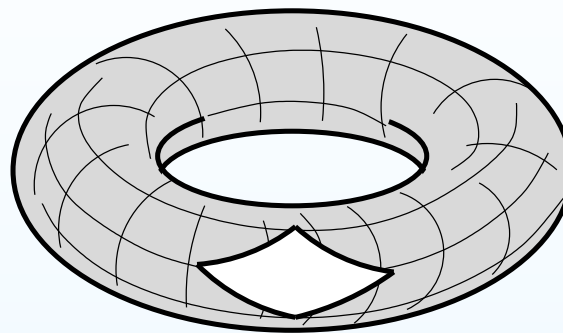
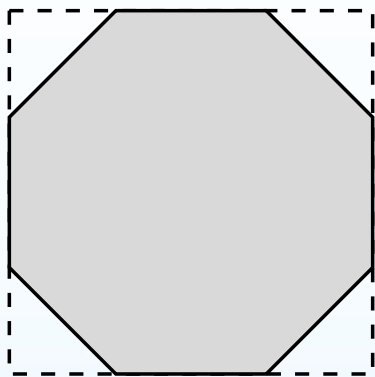

Identifying the opposite sides of a regular octagon we get a flat surface of genus two. All the vertices of the octagon are identified into a single conical singularity. We always consider such a flat surface endowed with a distinguished (say, vertical) direction. By construction, the holonomy of the flat metric is trivial. Thus, the vertical direction at a single point globally defines vertical and horizontal foliations.

Group action

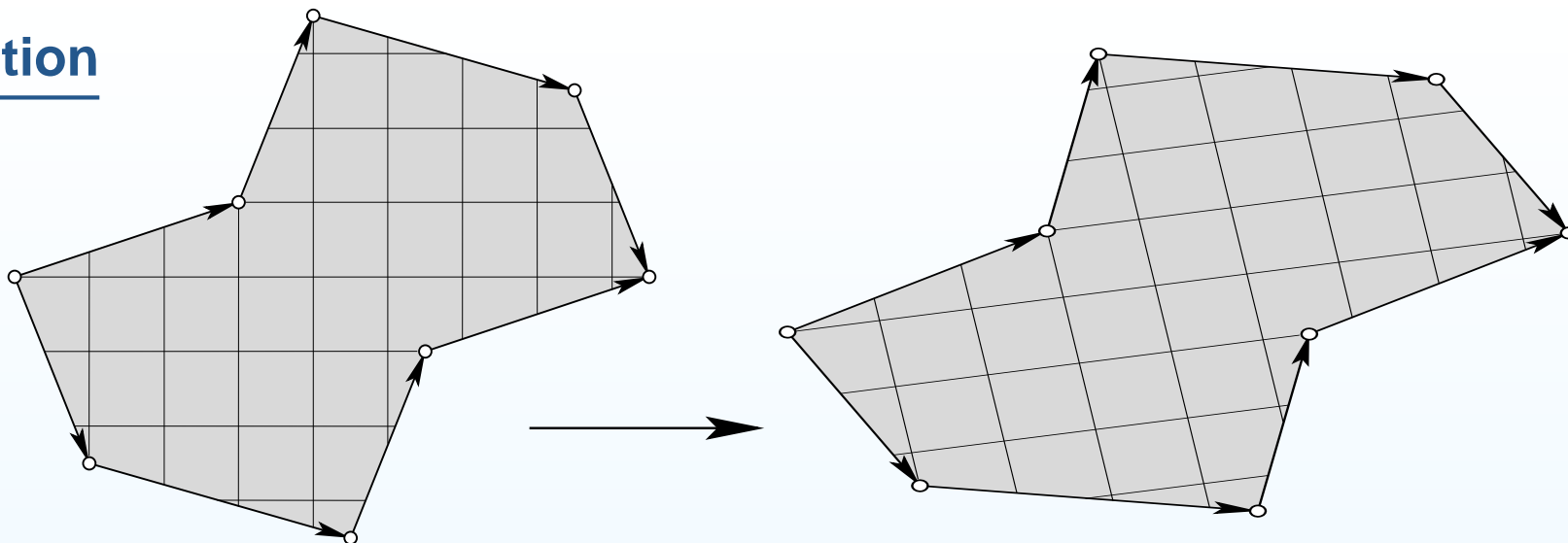

The group $SL(2, \mathbb{R})$ acts on each space $\mathcal{H}_1(d_1, \dots, d_n)$ of flat surfaces of unit area with conical singularities of prescribed cone angles $2\pi(d_i + 1)$. This action preserves the natural measure on this space. The diagonal subgroup $\begin{pmatrix} e^t & 0 \\ 0 & e^{-t} \end{pmatrix} \subset SL(2, \mathbb{R})$ induces a natural flow on $\mathcal{H}_1(d_1, \dots, d_n)$ called the *Teichmüller geodesic flow*.

Keystone Theorem (H. Masur; W. A. Veech, 1992). *The action of the groups $SL(2, \mathbb{R})$ and $\begin{pmatrix} e^t & 0 \\ 0 & e^{-t} \end{pmatrix}$ is ergodic with respect to the natural finite measure on each connected component of every space $\mathcal{H}_1(d_1, \dots, d_n)$.*

Group action

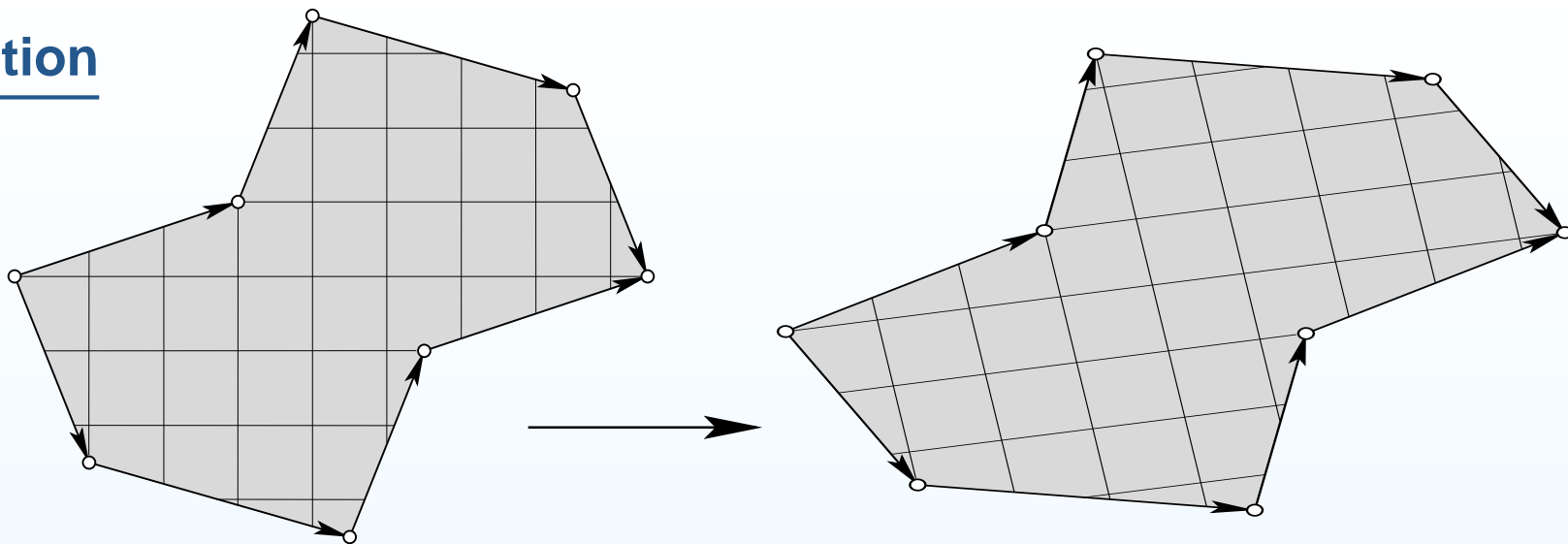

The group $SL(2, \mathbb{R})$ acts on each space $\mathcal{H}_1(d_1, \dots, d_n)$ of flat surfaces of unit area with conical singularities of prescribed cone angles $2\pi(d_i + 1)$. This action preserves the natural measure on this space. The diagonal subgroup $\begin{pmatrix} e^t & 0 \\ 0 & e^{-t} \end{pmatrix} \subset SL(2, \mathbb{R})$ induces a natural flow on $\mathcal{H}_1(d_1, \dots, d_n)$ called the *Teichmüller geodesic flow*.

Keystone Theorem (H. Masur; W. A. Veech, 1992). *The action of the groups $SL(2, \mathbb{R})$ and $\begin{pmatrix} e^t & 0 \\ 0 & e^{-t} \end{pmatrix}$ is ergodic with respect to the natural finite measure on each connected component of every space $\mathcal{H}_1(d_1, \dots, d_n)$.*

Masur—Veech Theorem: an illustration

Theorem of Masur and Veech claims that taking at random an octagon as below we can contract it horizontally and expand vertically by the same factor e^t to get arbitrary close to, say, regular octagon.

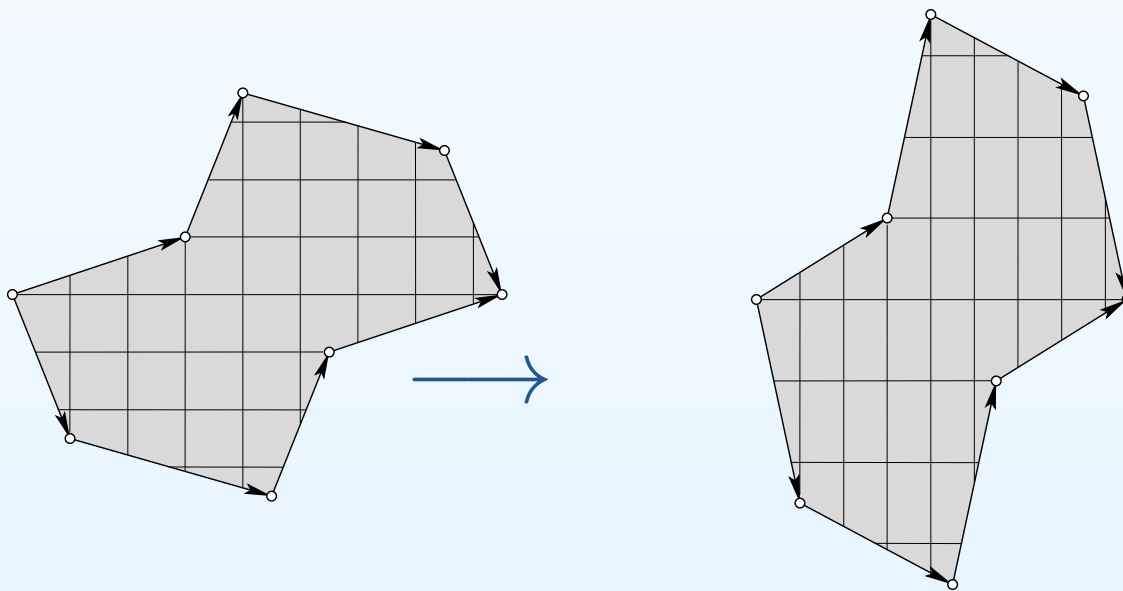

Masur—Veech Theorem: an illustration

Theorem of Masur and Veech claims that taking at random an octagon as below we can contract it horizontally and expand vertically by the same factor e^t to get arbitrary close to, say, regular octagon.

There is no paradox since we are allowed to cut-and-paste!

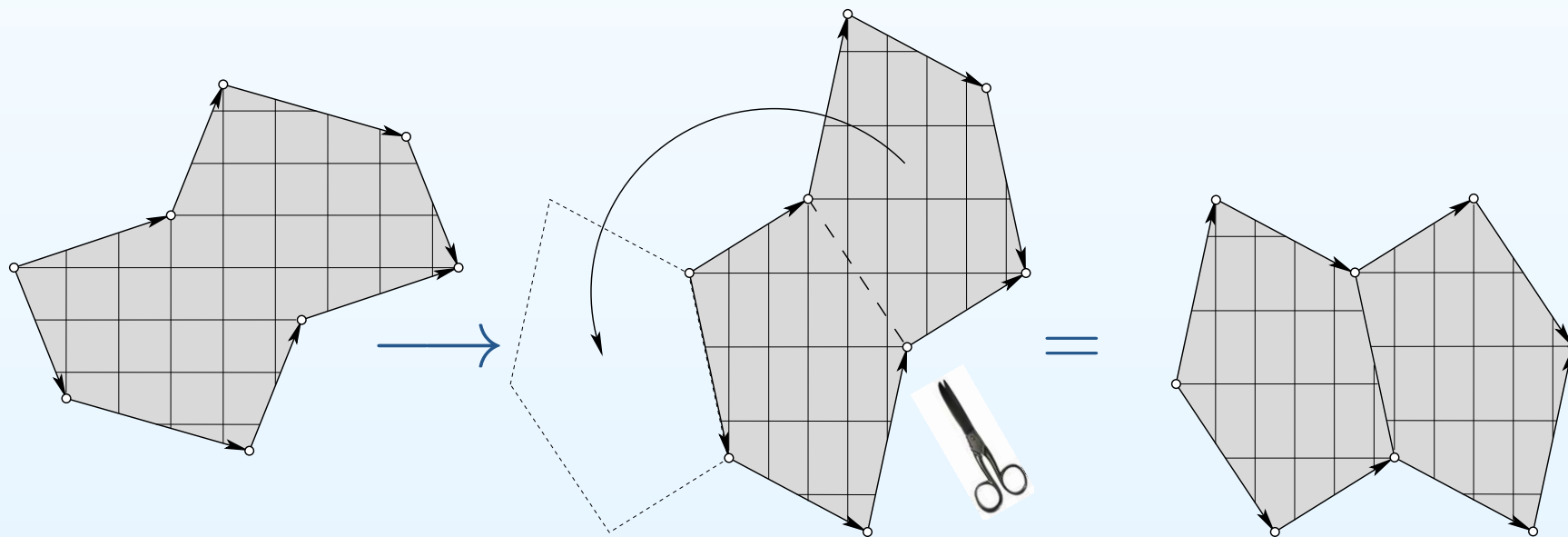

Masur—Veech Theorem: an illustration

Theorem of Masur and Veech claims that taking at random an octagon as below we can contract it horizontally and expand vertically by the same factor e^t to get arbitrary close to, say, regular octagon.

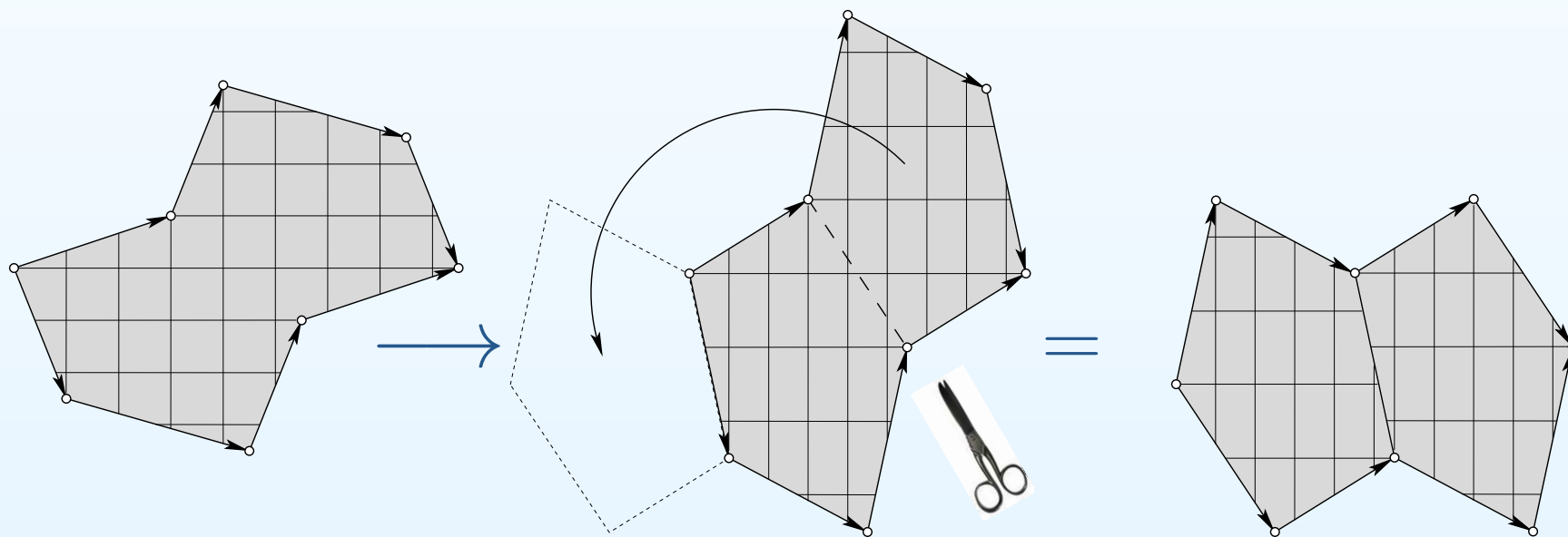

The first modification of the polygon changes the flat structure while the second one just changes the way in which we unwrap the flat surface.

Outline of section 1: vague idea of renormalization

We have reformulated the model problem of windtree billiard in terms of intersection indices $c(T) \circ h$ and $c(T) \circ v$ of a cycle $c(T)$ obtained by closing up a very long piece of vertical trajectory with two given cycles h and v on a given translation surface S .

Idea: apply the Teichmüller geodesic flow to S for an appropriate time t to get a flat surface $g_t S$ located very close to the original surface S . Close up the piece of Teichmüller geodesic to get an associated pseudo-Anosov diffeomorphism $f : S \rightarrow S$.

Note that g_t exponentially contracts the vertical direction. Choosing $t \simeq \log T$ we can transform the very long cycle $c(T)$ to an ordinary integer cycle $f_* c(T)$ of length comparable to 1.

Conclusion: to compute $c(T) \circ h = f_* c(T) \circ f_* h$ we have to figure out how the pseudo-Anosov diffeomorphism f corresponding to a long piece of a Teichmüller geodesic twists the first homology of the surface:

$$(g_t)_* : H_1(S, \mathbb{R}) \stackrel{?}{=} H_1(S, \mathbb{R}) \quad \text{when } t \rightarrow \infty.$$

0. Model problem:
diffusion in a periodic
billiard

1. Teichmüller dynamics

**2. Translation surfaces
as quadratic differentials**

- Very flat surfaces:
construction from a
polygon
- From flat to complex
structure
- From complex to flat
structure
- Dictionary
- Flat surfaces and
quadratic differentials
- Volumes of the strata
- Moduli spaces of
Abelian differentials

3. Renormalization and
deviation spectrum

2016. State of the art

∞. Challenges and
open directions

2. Translation surfaces as quadratic differentials

Very flat surfaces: construction from a polygon

Consider a broken line constructed from vectors $\vec{v}_1, \dots, \vec{v}_k$.

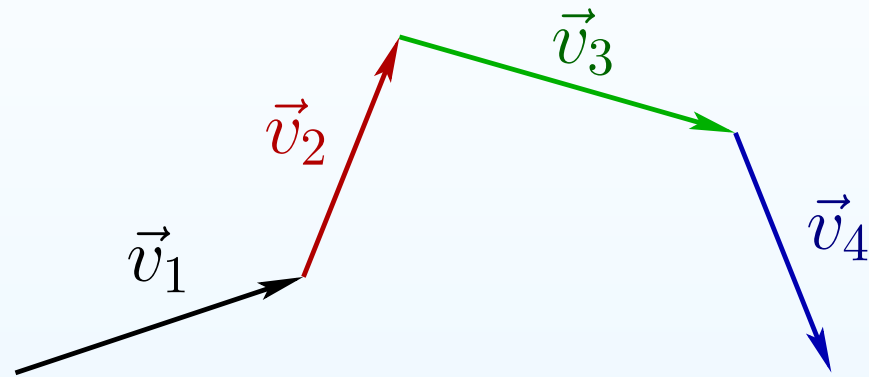

and another one constructed from the same vectors taken in another order.

Very flat surfaces: construction from a polygon

Consider a broken line constructed from vectors $\vec{v}_1, \dots, \vec{v}_k$.

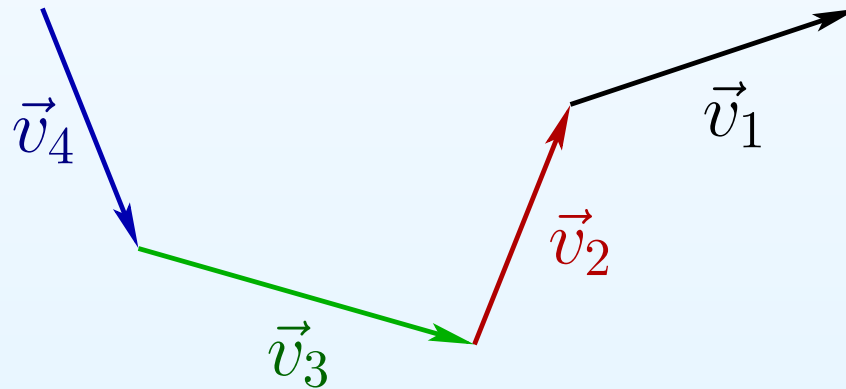

and another one constructed from the same vectors taken in another order.

Very flat surfaces: construction from a polygon

Consider a broken line constructed from vectors $\vec{v}_1, \dots, \vec{v}_k$.

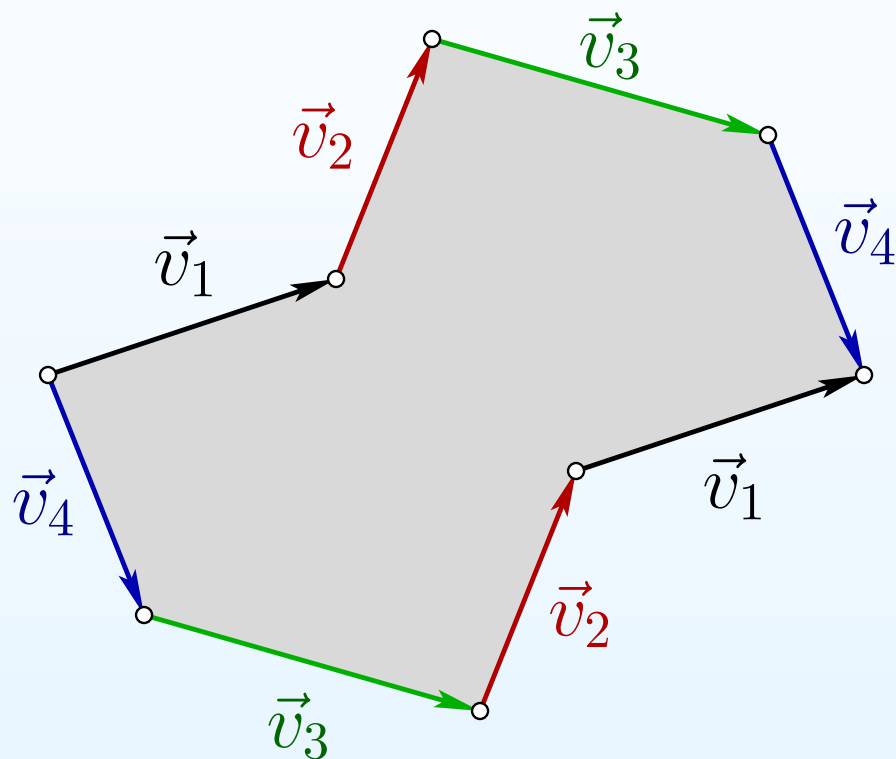

and another one constructed from the same vectors taken in another order. If we are lucky enough the two broken lines do not intersect and form a polygon.

Very flat surfaces: construction from a polygon

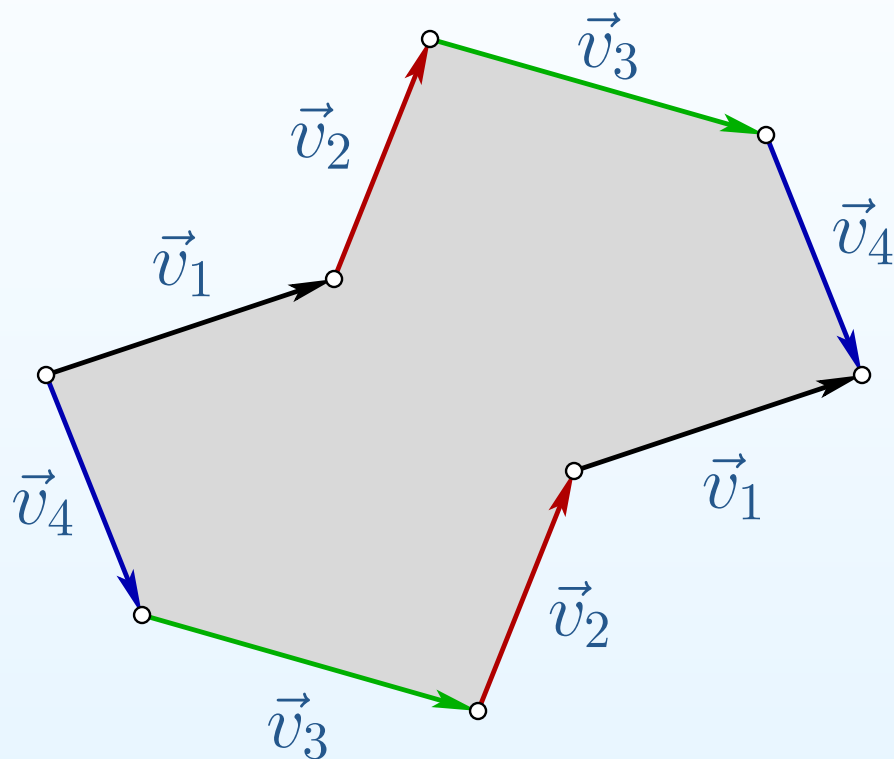

Identifying the corresponding pairs of sides by parallel translations we get a closed surface endowed with a flat metric.

Holomorphic 1-form associated to a flat structure

Consider the natural coordinate z in the complex plane, where lives the polygon. In this coordinate the parallel translations which we use to identify the sides of the polygon are represented as $z' = z + \text{const}$.

Since this correspondence is holomorphic, our flat surface S with punctured conical points inherits the complex structure. This complex structure extends to the punctured points.

Consider now a holomorphic 1-form dz in the complex plane. The coordinate z is not globally defined on the surface S . However, since the changes of local coordinates are defined as $z' = z + \text{const}$, we see that $dz = dz'$. Thus, the holomorphic 1-form dz on \mathbb{C} defines a holomorphic 1-form ω on S which in local coordinates has the form $\omega = dz$.

The form ω has zeroes exactly at those points of S where the flat structure has conical singularities.

Holomorphic 1-form associated to a flat structure

Consider the natural coordinate z in the complex plane, where lives the polygon. In this coordinate the parallel translations which we use to identify the sides of the polygon are represented as $z' = z + \text{const}$.

Since this correspondence is holomorphic, our flat surface S with punctured conical points inherits the complex structure. This complex structure extends to the punctured points.

Consider now a holomorphic 1-form dz in the complex plane. The coordinate z is not globally defined on the surface S . However, since the changes of local coordinates are defined as $z' = z + \text{const}$, we see that $dz = dz'$. Thus, the holomorphic 1-form dz on \mathbb{C} defines a holomorphic 1-form ω on S which in local coordinates has the form $\omega = dz$.

The form ω has zeroes exactly at those points of S where the flat structure has conical singularities.

Holomorphic 1-form associated to a flat structure

Consider the natural coordinate z in the complex plane, where lives the polygon. In this coordinate the parallel translations which we use to identify the sides of the polygon are represented as $z' = z + \text{const}$.

Since this correspondence is holomorphic, our flat surface S with punctured conical points inherits the complex structure. This complex structure extends to the punctured points.

Consider now a holomorphic 1-form dz in the complex plane. The coordinate z is not globally defined on the surface S . However, since the changes of local coordinates are defined as $z' = z + \text{const}$, we see that $dz = dz'$. Thus, the holomorphic 1-form dz on \mathbb{C} defines a holomorphic 1-form ω on S which in local coordinates has the form $\omega = dz$.

The form ω has zeroes exactly at those points of S where the flat structure has conical singularities.

Holomorphic 1-form associated to a flat structure

Consider the natural coordinate z in the complex plane, where lives the polygon. In this coordinate the parallel translations which we use to identify the sides of the polygon are represented as $z' = z + \text{const}$.

Since this correspondence is holomorphic, our flat surface S with punctured conical points inherits the complex structure. This complex structure extends to the punctured points.

Consider now a holomorphic 1-form dz in the complex plane. The coordinate z is not globally defined on the surface S . However, since the changes of local coordinates are defined as $z' = z + \text{const}$, we see that $dz = dz'$. Thus, the holomorphic 1-form dz on \mathbb{C} defines a holomorphic 1-form ω on S which in local coordinates has the form $\omega = dz$.

The form ω has zeroes exactly at those points of S where the flat structure has conical singularities.

Flat structure defined by a holomorphic 1-form

- Reciprocally a pair (Riemann surface, holomorphic 1-form) uniquely defines a flat structure: $z = \int \omega$.
- In a neighborhood of a zero a holomorphic 1-form can be represented as $w^d dw$, where d is a **degree** of the zero. The form ω has a zero of degree d at a conical point with cone angle $2\pi(d + 1)$. Moreover,
 $d_1 + \cdots + d_n = 2g - 2$.
- The moduli space \mathcal{H}_g of pairs (complex structure, holomorphic 1-form) is a \mathbb{C}^g -vector bundle over the moduli space \mathcal{M}_g of complex structures.
- The space \mathcal{H}_g is naturally stratified by the strata $\mathcal{H}(d_1, \dots, d_n)$ enumerated by unordered partitions $d_1 + \cdots + d_n = 2g - 2$.
- Any holomorphic 1-form corresponding to a fixed stratum $\mathcal{H}(d_1, \dots, d_n)$ has exactly n zeroes of degrees d_1, \dots, d_n .

Flat structure defined by a holomorphic 1-form

- Reciprocally a pair (Riemann surface, holomorphic 1-form) uniquely defines a flat structure: $z = \int \omega$.
- In a neighborhood of a zero a holomorphic 1-form can be represented as $w^d dw$, where d is a **degree** of the zero. The form ω has a zero of degree d at a conical point with cone angle $2\pi(d + 1)$. Moreover, $d_1 + \cdots + d_n = 2g - 2$.
- The moduli space \mathcal{H}_g of pairs (complex structure, holomorphic 1-form) is a \mathbb{C}^g -vector bundle over the moduli space \mathcal{M}_g of complex structures.
- The space \mathcal{H}_g is naturally stratified by the strata $\mathcal{H}(d_1, \dots, d_n)$ enumerated by unordered partitions $d_1 + \cdots + d_n = 2g - 2$.
- Any holomorphic 1-form corresponding to a fixed stratum $\mathcal{H}(d_1, \dots, d_n)$ has exactly n zeroes of degrees d_1, \dots, d_n .

Flat structure defined by a holomorphic 1-form

- Reciprocally a pair (Riemann surface, holomorphic 1-form) uniquely defines a flat structure: $z = \int \omega$.
- In a neighborhood of a zero a holomorphic 1-form can be represented as $w^d dw$, where d is a **degree** of the zero. The form ω has a zero of degree d at a conical point with cone angle $2\pi(d + 1)$. Moreover,
 $d_1 + \dots + d_n = 2g - 2$.
- The moduli space \mathcal{H}_g of pairs (complex structure, holomorphic 1-form) is a \mathbb{C}^g -vector bundle over the moduli space \mathcal{M}_g of complex structures.
- The space \mathcal{H}_g is naturally stratified by the strata $\mathcal{H}(d_1, \dots, d_n)$ enumerated by unordered partitions $d_1 + \dots + d_n = 2g - 2$.
- Any holomorphic 1-form corresponding to a fixed stratum $\mathcal{H}(d_1, \dots, d_n)$ has exactly n zeroes of degrees d_1, \dots, d_n .

Flat structure defined by a holomorphic 1-form

- Reciprocally a pair (Riemann surface, holomorphic 1-form) uniquely defines a flat structure: $z = \int \omega$.
- In a neighborhood of a zero a holomorphic 1-form can be represented as $w^d dw$, where d is a **degree** of the zero. The form ω has a zero of degree d at a conical point with cone angle $2\pi(d + 1)$. Moreover,
 $d_1 + \cdots + d_n = 2g - 2$.
- The moduli space \mathcal{H}_g of pairs (complex structure, holomorphic 1-form) is a \mathbb{C}^g -vector bundle over the moduli space \mathcal{M}_g of complex structures.
- The space \mathcal{H}_g is naturally stratified by the strata $\mathcal{H}(d_1, \dots, d_n)$ enumerated by unordered partitions $d_1 + \cdots + d_n = 2g - 2$.
- Any holomorphic 1-form corresponding to a fixed stratum $\mathcal{H}(d_1, \dots, d_n)$ has exactly n zeroes of degrees d_1, \dots, d_n .

Flat structure defined by a holomorphic 1-form

- Reciprocally a pair (Riemann surface, holomorphic 1-form) uniquely defines a flat structure: $z = \int \omega$.
- In a neighborhood of a zero a holomorphic 1-form can be represented as $w^d dw$, where d is a **degree** of the zero. The form ω has a zero of degree d at a conical point with cone angle $2\pi(d + 1)$. Moreover,
$$d_1 + \cdots + d_n = 2g - 2.$$
- The moduli space \mathcal{H}_g of pairs (complex structure, holomorphic 1-form) is a \mathbb{C}^g -vector bundle over the moduli space \mathcal{M}_g of complex structures.
- The space \mathcal{H}_g is naturally stratified by the strata $\mathcal{H}(d_1, \dots, d_n)$ enumerated by unordered partitions $d_1 + \cdots + d_n = 2g - 2$.
- Any holomorphic 1-form corresponding to a fixed stratum $\mathcal{H}(d_1, \dots, d_n)$ has exactly n zeroes of degrees d_1, \dots, d_n .

Geometric language	Complex-analytic language
flat structure (including a choice of the vertical direction)	complex structure and a choice of a holomorphic 1-form ω
conical point with a cone angle $2\pi(d + 1)$	zero of degree d of the holomorphic 1-form ω (in local coordinates $\omega = w^d dw$)
side \vec{v}_j of a polygon	relative period $\int_{P_j}^{P_{j+1}} \omega = \int_{\vec{v}_j} dz$ of the 1-form ω
family of flat surfaces sharing the same cone angles $2\pi(d_1 + 1), \dots, 2\pi(d_n + 1)$	stratum $\mathcal{H}(d_1, \dots, d_n)$ in the moduli space of holomorphic 1-forms
local coordinates in the family: vectors \vec{v}_i defining the polygon	local coordinates in $\mathcal{H}(d_1, \dots, d_n)$: relative periods of ω in $H^1(S, \{P_1, \dots, P_n\}; \mathbb{C})$

Flat surfaces and quadratic differentials

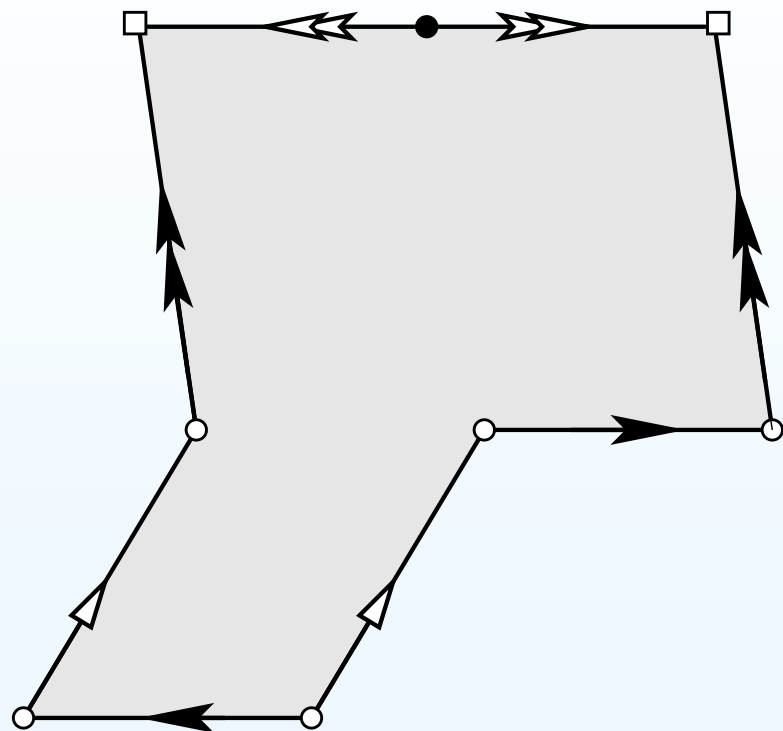

Identifying pairs of sides of this polygon by isometries we obtain a surface of genus $g = 1$. Now the flat metric has holonomy group $\mathbb{Z}/2\mathbb{Z}$; cone angles are integer multiples of π . Flat surfaces of this type correspond to quadratic differentials. For example, the quadratic differential representing the surface from the picture belongs to the stratum $\mathcal{Q}(2, -1, -1)$.

The flat metric associated to a meromorphic quadratic differential has finite area if and only if the quadratic differential has at most simple poles.

Flat surfaces and quadratic differentials

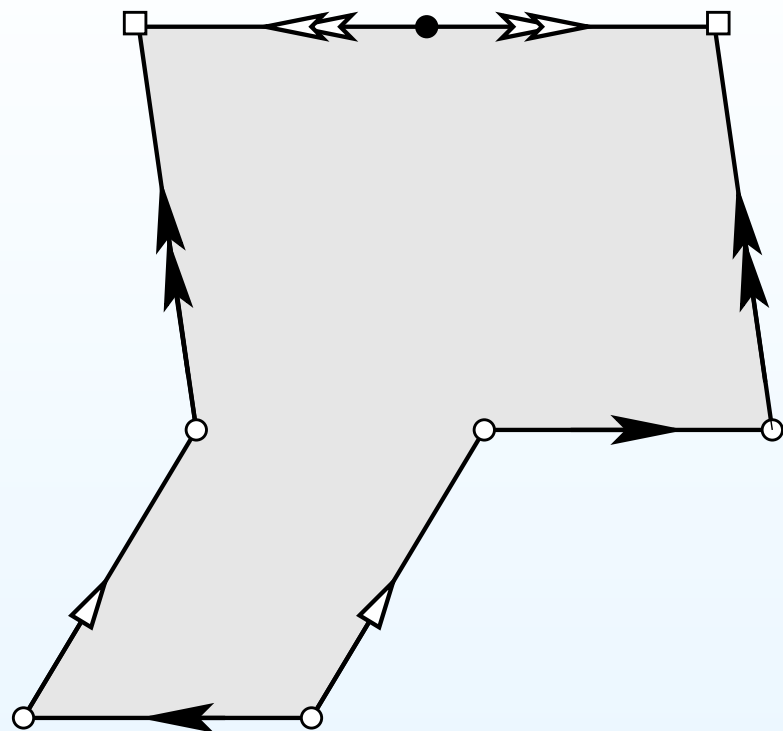

Identifying pairs of sides of this polygon by isometries we obtain a surface of genus $g = 1$. Now the flat metric has holonomy group $\mathbb{Z}/2\mathbb{Z}$; cone angles are integer multiples of π . Flat surfaces of this type correspond to quadratic differentials. For example, the quadratic differential representing the surface from the picture belongs to the stratum $\mathcal{Q}(2, -1, -1)$.

The flat metric associated to a meromorphic quadratic differential has finite area if and only if the quadratic differential has at most simple poles.

Volumes of the strata

Note that the vector space $H^1(S, \{P_1, \dots, P_n\}; \mathbb{C})$ contains a natural integer lattice $H^1(S, \{P_1, \dots, P_n\}; \mathbb{Z} \oplus \sqrt{-1}\mathbb{Z})$. Consider a linear volume element $d\nu$ normalized in such a way that the volume of the fundamental domain in this lattice equals one. Consider now a real hypersurface $\mathcal{H}_1(d_1, \dots, d_n) \subset \mathcal{H}(d_1, \dots, d_n)$ defined by the equation $area(S) = 1$, or, equivalently, $\frac{i}{2} \int_S \omega \wedge \bar{\omega} = \frac{i}{2} \sum_{i=1}^g A_i \bar{B}_i - \bar{A}_i B_i = 1$. The volume element $d\nu$ can be naturally restricted to the hypersurface defining the volume element $d\nu_1$ on $\mathcal{H}_1(d_1, \dots, d_n)$.

Theorem (H. Masur; W. A. Veech; 1982) *The total volume $\text{Vol}(\mathcal{H}_1(d_1, \dots, d_n))$, $\text{Vol}(\mathcal{Q}_1(d_1, \dots, d_n))$ of every stratum is finite.*

An algorithm for volume computation was elaborated by Eskin and Okounkov in 2001. The Masur–Veech volumes of strata are always rational multiples of π^{2g} .

Volumes of the strata

Theorem (H. Masur; W. A. Veech; 1982) *The total volume $\text{Vol}(\mathcal{H}_1(d_1, \dots, d_n))$, $\text{Vol}(\mathcal{Q}_1(d_1, \dots, d_n))$ of every stratum is finite.*

An algorithm for volume computation was elaborated by Eskin and Okounkov in 2001. The Masur–Veech volumes of strata are always rational multiples of π^{2g} .

The corresponding rational numbers for all strata of Abelian differentials in genera $g \leq 10$ (and for some strata up to genus 200) were evaluated by A. Eskin. The algorithm of Eskin and Okounkov for strata of quadratic differentials was recently implemented by E. Goujard, who computed the volumes of the first 300 low-dimensional strata.

Volumes of the strata

Theorem (H. Masur; W. A. Veech; 1982) *The total volume $\text{Vol}(\mathcal{H}_1(d_1, \dots, d_n))$, $\text{Vol}(\mathcal{Q}_1(d_1, \dots, d_n))$ of every stratum is finite.*

An algorithm for volume computation was elaborated by Eskin and Okounkov in 2001. The Masur–Veech volumes of strata are always rational multiples of π^{2g} .

The corresponding rational numbers for all strata of Abelian differentials in genera $g \leq 10$ (and for some strata up to genus 200) were evaluated by A. Eskin. The algorithm of Eskin and Okounkov for strata of quadratic differentials was recently implemented by E. Goujard, who computed the volumes of the first 300 low-dimensional strata.

Volumes of strata of quadratic differentials in genus 0 are described by a simple formula (conjectured by Kontsevich and recently proved by Athreya–Eskin–Z.). Volumes of strata of *Abelian* differentials have simple large genus asymptotics (conjectured by Eskin–Z. and almost proved by Chen–Möller-Zagier). Elise Goujard will tell more about volumes in her talk.

Moduli spaces of Abelian differentials

We have seen that any stratum $\mathcal{H}(m_1, \dots, m_n)$ of all pairs (Riemann surface S , holomorphic 1-form with n zeroes of degrees m_1, \dots, m_n) is locally modeled on $H^1(S, \{n \text{ points}\}; \mathbb{C})$ and, thus, is endowed with a canonical volume element $d\nu$ (the one normalized by the integer lattice).

The group $SL(2, \mathbb{R})$ acts on the second term in the tensor product

$$H^1(S, \{n \text{ points}\}; \mathbb{R} \oplus i\mathbb{R}) \simeq H^1(S, \{n \text{ points}\}; \mathbb{R}) \otimes \mathbb{R}^2 .$$

The projectivized stratum

$P\mathcal{H}(m_1, \dots, m_n) \simeq \mathcal{H}_1(m_1, \dots, m_n) / SO(2, \mathbb{R}) \simeq \mathcal{H}(m_1, \dots, m_n) / \mathbb{C}^*$ is foliated by hyperbolic planes $\mathbb{H}^2 = SL(2, \mathbb{R}) / SO(2, \mathbb{R})$ called *Teichmüller discs*. The natural projection of such disc to \mathcal{M}_g is an isometric imbedding, so Teichmüller discs are *complex geodesics* in the Teichmüller metric on \mathcal{M}_g .

Similarly, any stratum of meromorphic quadratic differentials with at most simple poles is locally modeled on the anti-invariant subspace of $H^1(\hat{S}, \{n \text{ points}\}; \mathbb{C})$, where $p : \hat{S} \rightarrow S$ is the canonical double cover such that $p^*q = \omega^2$ becomes a global square of a holomorphic form ω .

Moduli spaces of Abelian differentials

We have seen that any stratum $\mathcal{H}(m_1, \dots, m_n)$ of all pairs (Riemann surface S , holomorphic 1-form with n zeroes of degrees m_1, \dots, m_n) is locally modeled on $H^1(S, \{n \text{ points}\}; \mathbb{C})$ and, thus, is endowed with a canonical volume element $d\nu$ (the one normalized by the integer lattice).

The group $SL(2, \mathbb{R})$ acts on the second term in the tensor product

$$H^1(S, \{n \text{ points}\}; \mathbb{R} \oplus i\mathbb{R}) \simeq H^1(S, \{n \text{ points}\}; \mathbb{R}) \otimes \mathbb{R}^2 .$$

The projectivized stratum

$P\mathcal{H}(m_1, \dots, m_n) \simeq \mathcal{H}_1(m_1, \dots, m_n) / SO(2, \mathbb{R}) \simeq \mathcal{H}(m_1, \dots, m_n) / \mathbb{C}^*$ is foliated by hyperbolic planes $\mathbb{H}^2 = SL(2, \mathbb{R}) / SO(2, \mathbb{R})$ called *Teichmüller discs*. The natural projection of such disc to \mathcal{M}_g is an isometric imbedding, so Teichmüller discs are *complex geodesics* in the Teichmüller metric on \mathcal{M}_g .

Similarly, any stratum of meromorphic quadratic differentials with at most simple poles is locally modeled on the anti-invariant subspace of $H^1(\hat{S}, \{n \text{ points}\}; \mathbb{C})$, where $p : \hat{S} \rightarrow S$ is the canonical double cover such that $p^*q = \omega^2$ becomes a global square of a holomorphic form ω .

Moduli spaces of Abelian differentials

We have seen that any stratum $\mathcal{H}(m_1, \dots, m_n)$ of all pairs (Riemann surface S , holomorphic 1-form with n zeroes of degrees m_1, \dots, m_n) is locally modeled on $H^1(S, \{n \text{ points}\}; \mathbb{C})$ and, thus, is endowed with a canonical volume element $d\nu$ (the one normalized by the integer lattice).

The group $\mathrm{SL}(2, \mathbb{R})$ acts on the second term in the tensor product

$$H^1(S, \{n \text{ points}\}; \mathbb{R} \oplus i\mathbb{R}) \simeq H^1(S, \{n \text{ points}\}; \mathbb{R}) \otimes \mathbb{R}^2 .$$

The projectivized stratum

$\mathrm{PH}(m_1, \dots, m_n) \simeq \mathcal{H}_1(m_1, \dots, m_n) / \mathrm{SO}(2, \mathbb{R}) \simeq \mathcal{H}(m_1, \dots, m_n) / \mathbb{C}^*$ is foliated by hyperbolic planes $\mathbb{H}^2 = \mathrm{SL}(2, \mathbb{R}) / \mathrm{SO}(2, \mathbb{R})$ called *Teichmüller discs*. The natural projection of such disc to \mathcal{M}_g is an isometric imbedding, so Teichmüller discs are *complex geodesics* in the Teichmüller metric on \mathcal{M}_g .

Similarly, any stratum of meromorphic quadratic differentials with at most simple poles is locally modeled on the anti-invariant subspace of $H^1(\hat{S}, \{n \text{ points}\}; \mathbb{C})$, where $p : \hat{S} \rightarrow S$ is the canonical double cover such that $p^*q = \omega^2$ becomes a global square of a holomorphic form ω .

Moduli spaces of Abelian differentials

We have seen that any stratum $\mathcal{H}(m_1, \dots, m_n)$ of all pairs (Riemann surface S , holomorphic 1-form with n zeroes of degrees m_1, \dots, m_n) is locally modeled on $H^1(S, \{n \text{ points}\}; \mathbb{C})$ and, thus, is endowed with a canonical volume element $d\nu$ (the one normalized by the integer lattice).

The group $\mathrm{SL}(2, \mathbb{R})$ acts on the second term in the tensor product

$$H^1(S, \{n \text{ points}\}; \mathbb{R} \oplus i\mathbb{R}) \simeq H^1(S, \{n \text{ points}\}; \mathbb{R}) \otimes \mathbb{R}^2.$$

The projectivized stratum

$\mathrm{PH}(m_1, \dots, m_n) \simeq \mathcal{H}_1(m_1, \dots, m_n) / \mathrm{SO}(2, \mathbb{R}) \simeq \mathcal{H}(m_1, \dots, m_n) / \mathbb{C}^*$ is foliated by hyperbolic planes $\mathbb{H}^2 = \mathrm{SL}(2, \mathbb{R}) / \mathrm{SO}(2, \mathbb{R})$ called *Teichmüller discs*. The natural projection of such disc to \mathcal{M}_g is an isometric imbedding, so Teichmüller discs are *complex geodesics* in the Teichmüller metric on \mathcal{M}_g .

Similarly, any stratum of meromorphic quadratic differentials with at most simple poles is locally modeled on the anti-invariant subspace of $H^1(\hat{S}, \{n \text{ points}\}; \mathbb{C})$, where $p : \hat{S} \rightarrow S$ is the canonical double cover such that $p^*q = \omega^2$ becomes a global square of a holomorphic form ω .

*“But still, my homeward way has proved too long.
While we were wasting time there, old Poseidon,
it almost seems, stretched and extended space.”*

J. Brodsky

*И все-таки ведущая домой дорога
оказалась слишком длинной,
как будто Посейдон, пока мы там
теряли время, растянул пространство.*

И. Бродский

3. Renormalization and deviation spectrum

0. Model problem:
diffusion in a periodic
billiard

1. Teichmüller dynamics

2. Translation surfaces
as quadratic differentials

3. Renormalization and
deviation spectrum

- Asymptotic cycle
- First return cycles
- Renormalization
- Asymptotic flag:
empirical description
- Multiplicative ergodic
theorem
- Hodge bundle
- Selected (mostly
geometric) results of
1996–2012

2016. State of the art

∞. Challenges and
open directions

Asymptotic cycle for a torus

Consider a leaf of a measured foliation on a surface. Choose a short transversal segment X . Each time when the leaf crosses X we join the crossing point with the point x_0 along X obtaining a closed loop. Consecutive return points x_1, x_2, \dots define a sequence of cycles c_1, c_2, \dots .

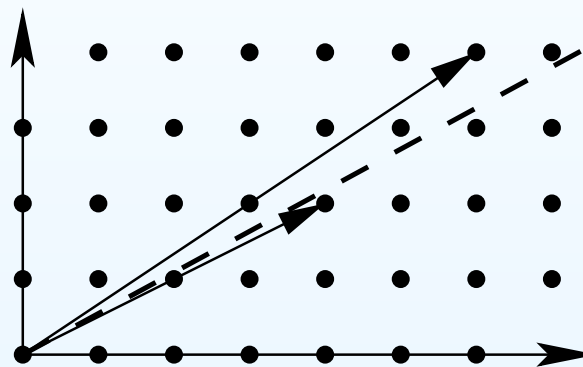
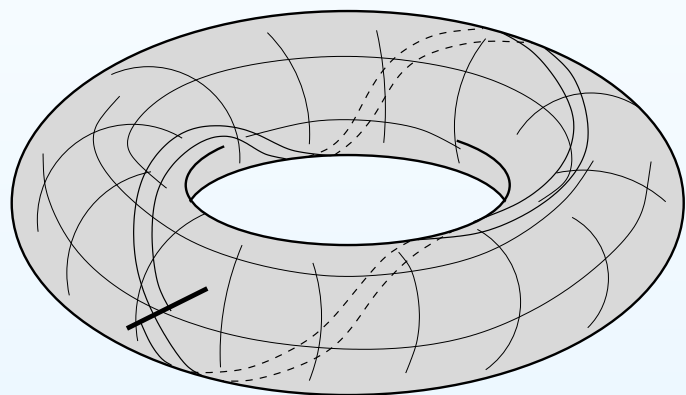

The *asymptotic cycle* is defined as $\lim_{n \rightarrow \infty} \frac{c_n}{n} = c \in H_1(\mathbb{T}^2; \mathbb{R})$.

Theorem (S. Kerckhoff, H. Masur, J. Smillie, 1986.) *For any flat surface directional flow in almost any direction is uniquely ergodic.*

This implies that for almost any direction the asymptotic cycle exists and is the same for all points of the surface.

Asymptotic cycle for a torus

Consider a leaf of a measured foliation on a surface. Choose a short transversal segment X . Each time when the leaf crosses X we join the crossing point with the point x_0 along X obtaining a closed loop. Consecutive return points x_1, x_2, \dots define a sequence of cycles c_1, c_2, \dots .

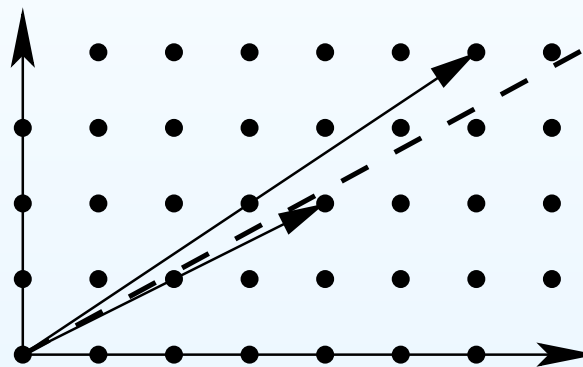
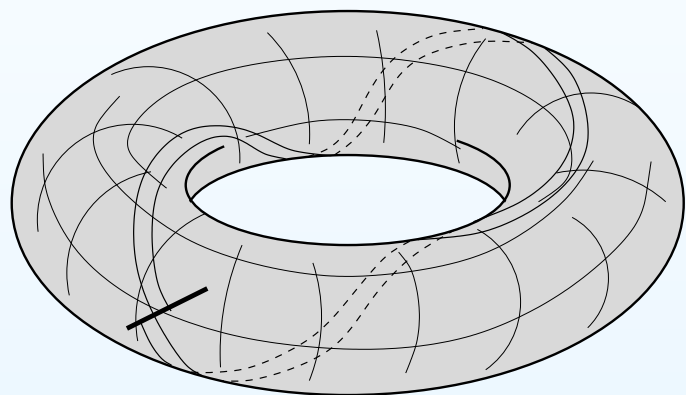

The *asymptotic cycle* is defined as $\lim_{n \rightarrow \infty} \frac{c_n}{n} = c \in H_1(\mathbb{T}^2; \mathbb{R})$.

Theorem (S. Kerckhoff, H. Masur, J. Smillie, 1986.) *For any flat surface directional flow in almost any direction is uniquely ergodic.*

This implies that for almost any direction the asymptotic cycle exists and is the same for all points of the surface.

Asymptotic cycle in the pseudo-Anosov case

Consider a model case of the foliation in direction of the expanding eigenvector \vec{v}_u of the Anosov map $g : \mathbb{T}^2 \rightarrow \mathbb{T}^2$ with $Dg = A = \begin{pmatrix} 1 & 1 \\ 1 & 2 \end{pmatrix}$. Take a closed curve γ and apply to it k iterations of g . The images $g_*^{(k)}(c)$ of the corresponding cycle $c = [\gamma]$ get almost collinear to the expanding eigenvector \vec{v}_u of A , and the corresponding curve $g^{(k)}(\gamma)$ closely follows our foliation.

The first return cycles to a short subinterval exhibit exactly the same behavior by a simple reason that they are images of the first return cycles to a longer subinterval under a high iteration of g .

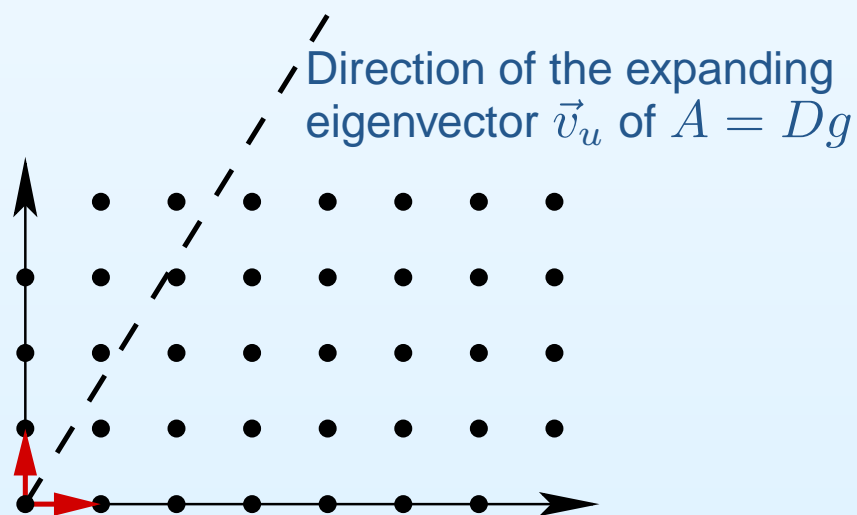

Asymptotic cycle in the pseudo-Anosov case

Consider a model case of the foliation in direction of the expanding eigenvector \vec{v}_u of the Anosov map $g : \mathbb{T}^2 \rightarrow \mathbb{T}^2$ with $Dg = A = \begin{pmatrix} 1 & 1 \\ 1 & 2 \end{pmatrix}$. Take a closed curve γ and apply to it k iterations of g . The images $g_*^{(k)}(c)$ of the corresponding cycle $c = [\gamma]$ get almost collinear to the expanding eigenvector \vec{v}_u of A , and the corresponding curve $g^{(k)}(\gamma)$ closely follows our foliation.

The first return cycles to a short subinterval exhibit exactly the same behavior by a simple reason that they are images of the first return cycles to a longer subinterval under a high iteration of g .

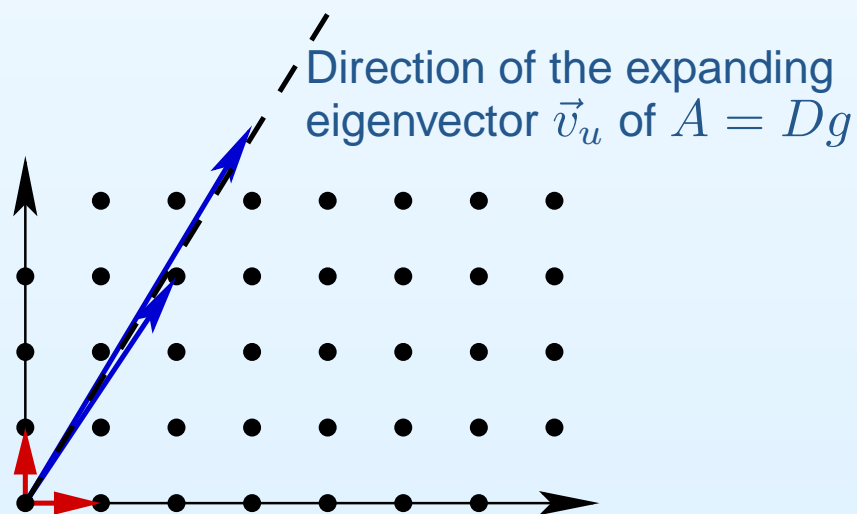

Asymptotic cycle in the pseudo-Anosov case

Consider a model case of the foliation in direction of the expanding eigenvector \vec{v}_u of the Anosov map $g : \mathbb{T}^2 \rightarrow \mathbb{T}^2$ with $Dg = A = \begin{pmatrix} 1 & 1 \\ 1 & 2 \end{pmatrix}$. Take a closed curve γ and apply to it k iterations of g . The images $g_*^{(k)}(c)$ of the corresponding cycle $c = [\gamma]$ get almost collinear to the expanding eigenvector \vec{v}_u of A , and the corresponding curve $g^{(k)}(\gamma)$ closely follows our foliation.

The first return cycles to a short subinterval exhibit exactly the same behavior by a simple reason that they are images of the first return cycles to a longer subinterval under a high iteration of g .

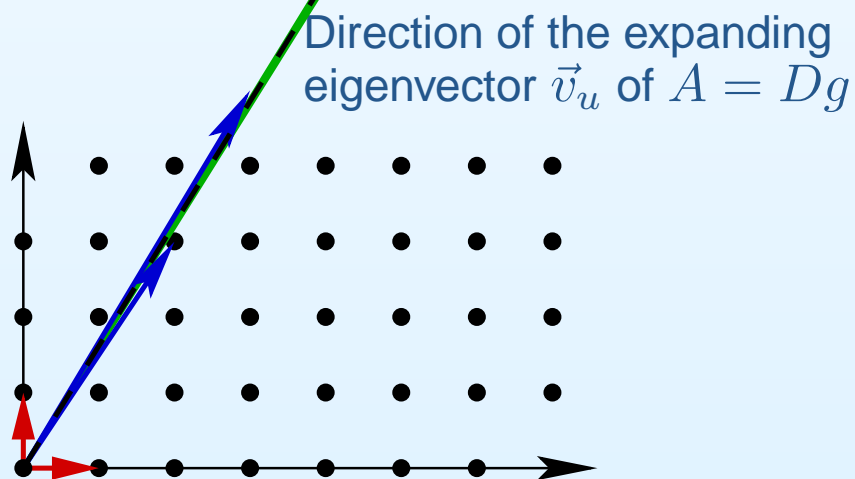

Asymptotic cycle in the pseudo-Anosov case

Consider a model case of the foliation in direction of the expanding eigenvector \vec{v}_u of the Anosov map $g : \mathbb{T}^2 \rightarrow \mathbb{T}^2$ with $Dg = A = \begin{pmatrix} 1 & 1 \\ 1 & 2 \end{pmatrix}$. Take a closed curve γ and apply to it k iterations of g . The images $g_*^{(k)}(c)$ of the corresponding cycle $c = [\gamma]$ get almost collinear to the expanding eigenvector \vec{v}_u of A , and the corresponding curve $g^{(k)}(\gamma)$ closely follows our foliation.

The first return cycles to a short subinterval exhibit exactly the same behavior by a simple reason that they are images of the first return cycles to a longer subinterval under a high iteration of g .

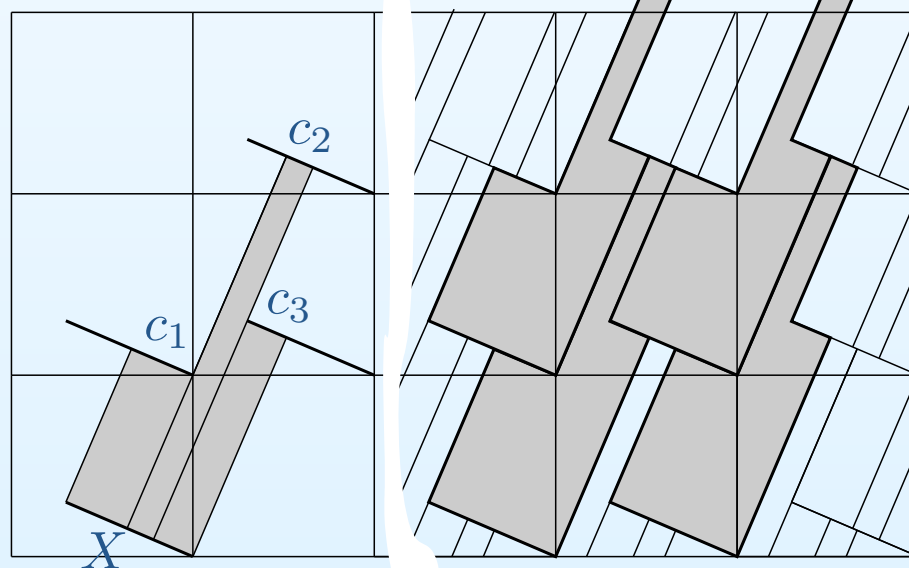
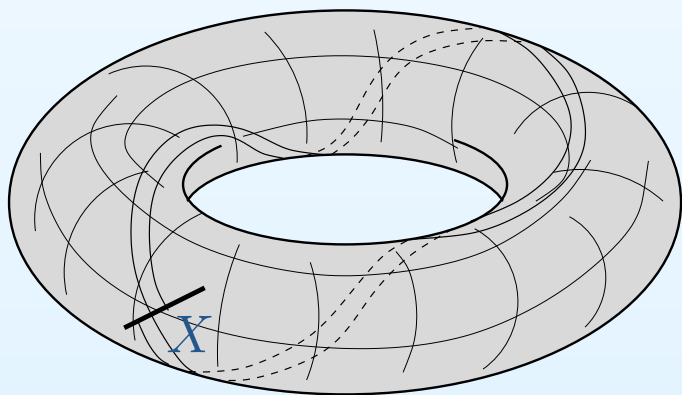

First return cycle $c_i(g(X))$ to $g(X)$ is $g_*(c_i(X))$

First return cycles

One should not think that in this phenomenon there is something special for a torus. The same story is valid for any pseudo-Anosov diffeomorphism g : first return cycles of the expanding foliation to a subinterval X of the contracting foliation are mapped by g to the first return cycles to a shorter subinterval $g(X)$.

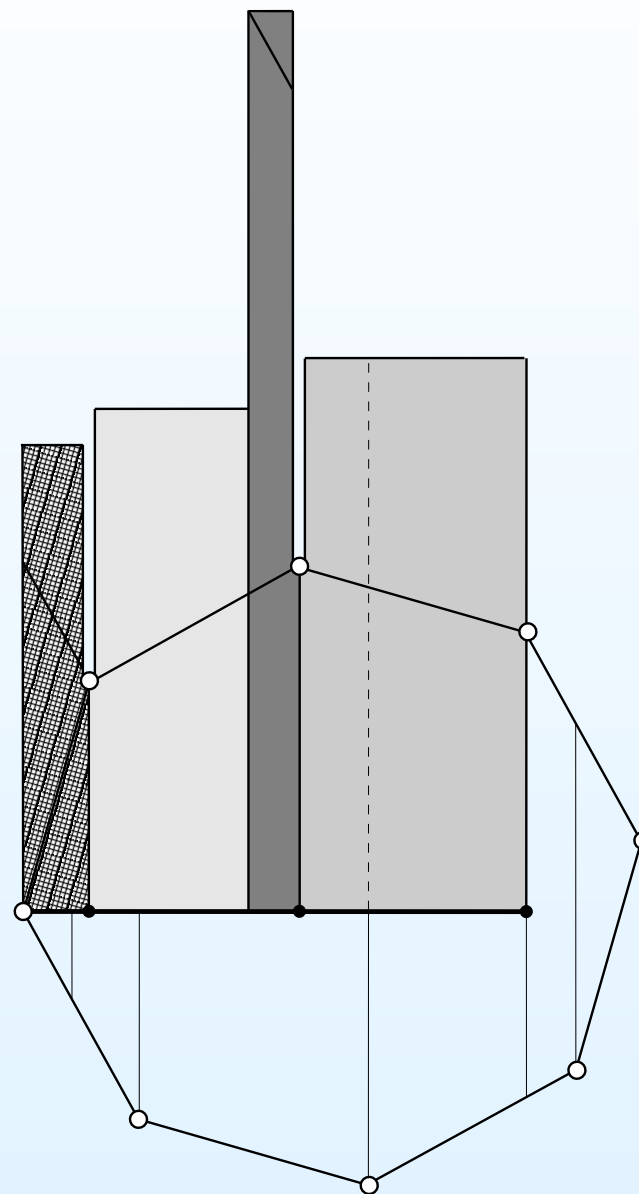
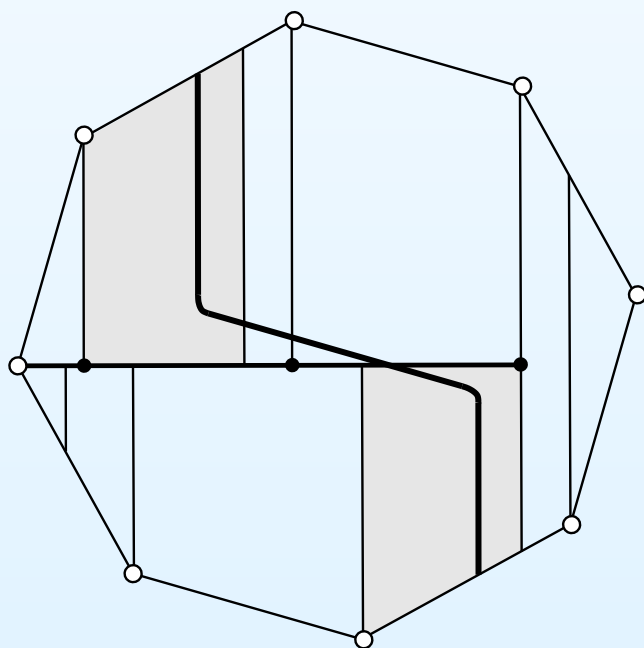

Idea of a renormalization

By the theorem of Masur and Veech, the homogeneous expansion-contraction in vertical-horizontal directions regularly brings almost any flat surface, basically, back to itself. Multiplicative ergodic theorem states that, in a sense, there a matrix (one and the same for almost all flat surfaces) which mimics the matrix of a fixed pseudo-Anosov diffeomorphism as if the Teichmüller flow would be periodic.

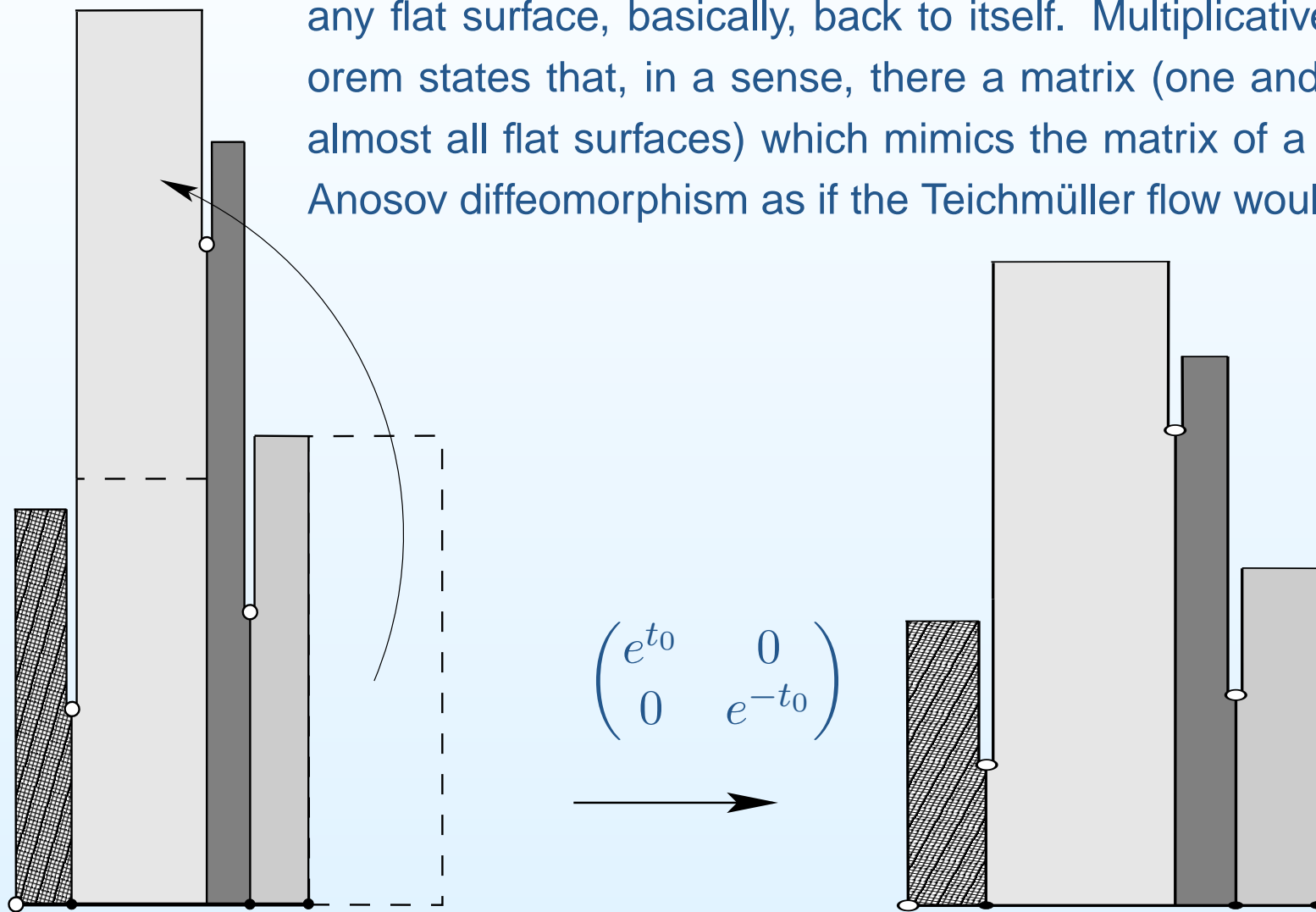

Asymptotic flag: empirical description

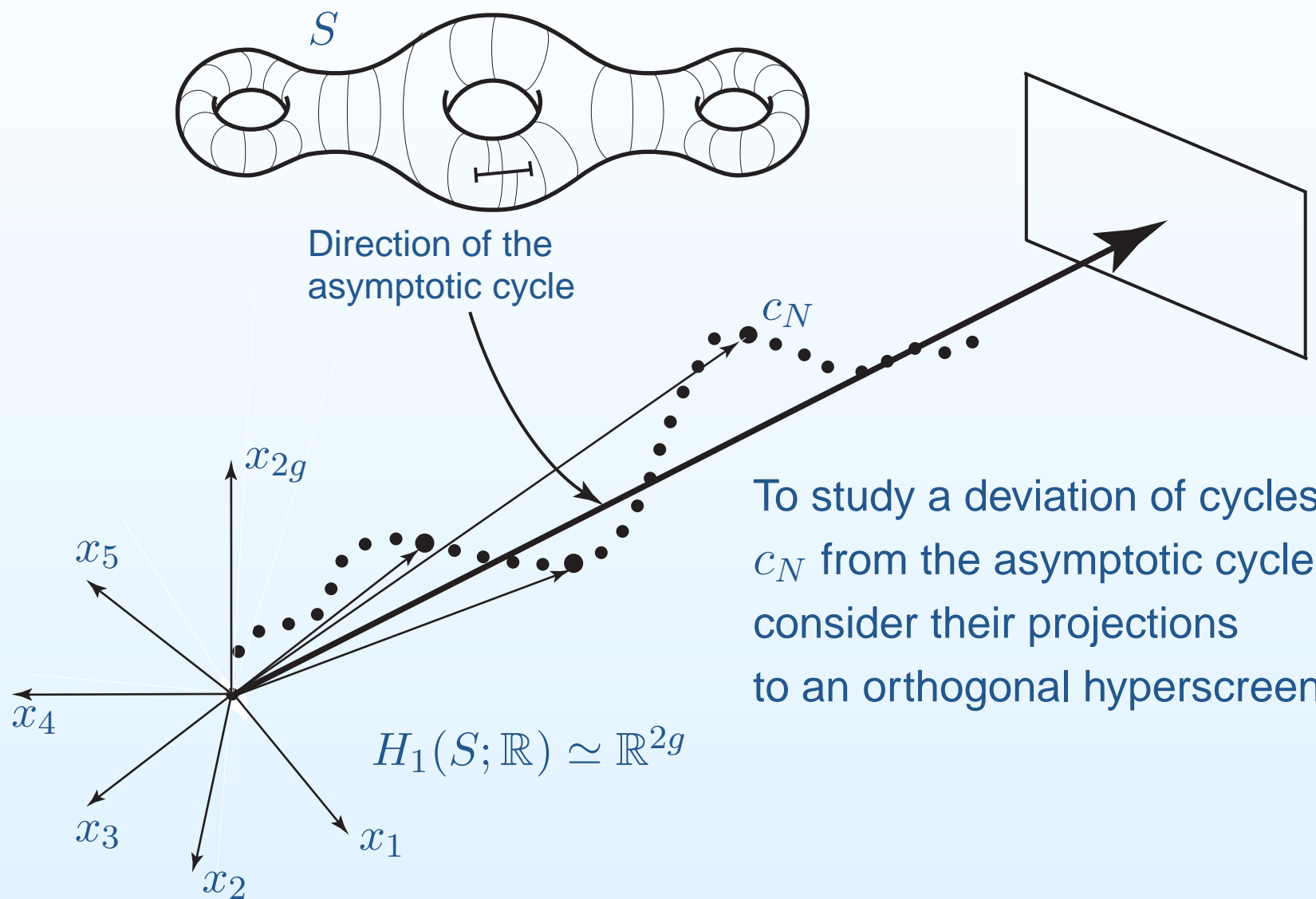

Asymptotic flag: empirical description

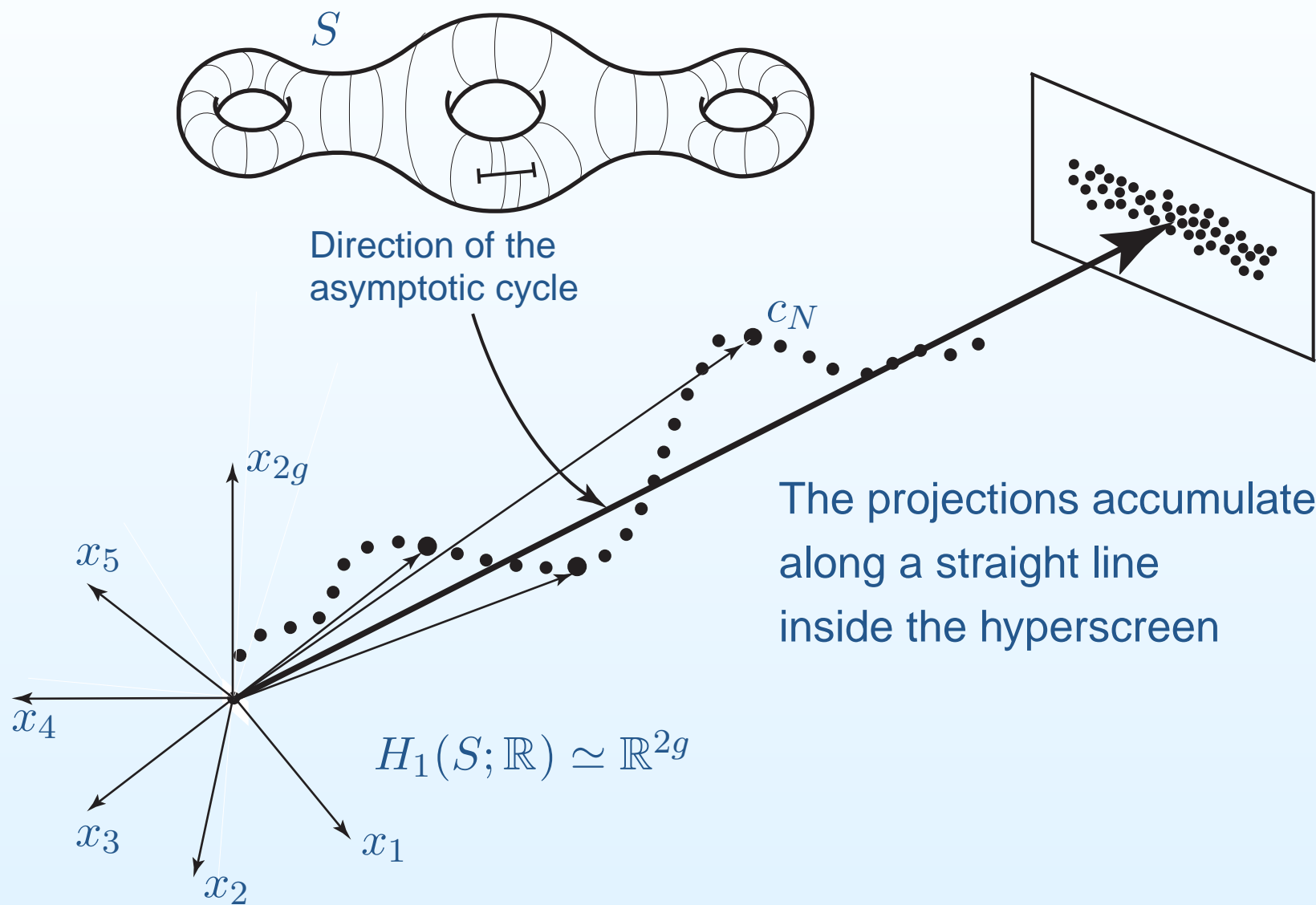

Asymptotic flag: empirical description

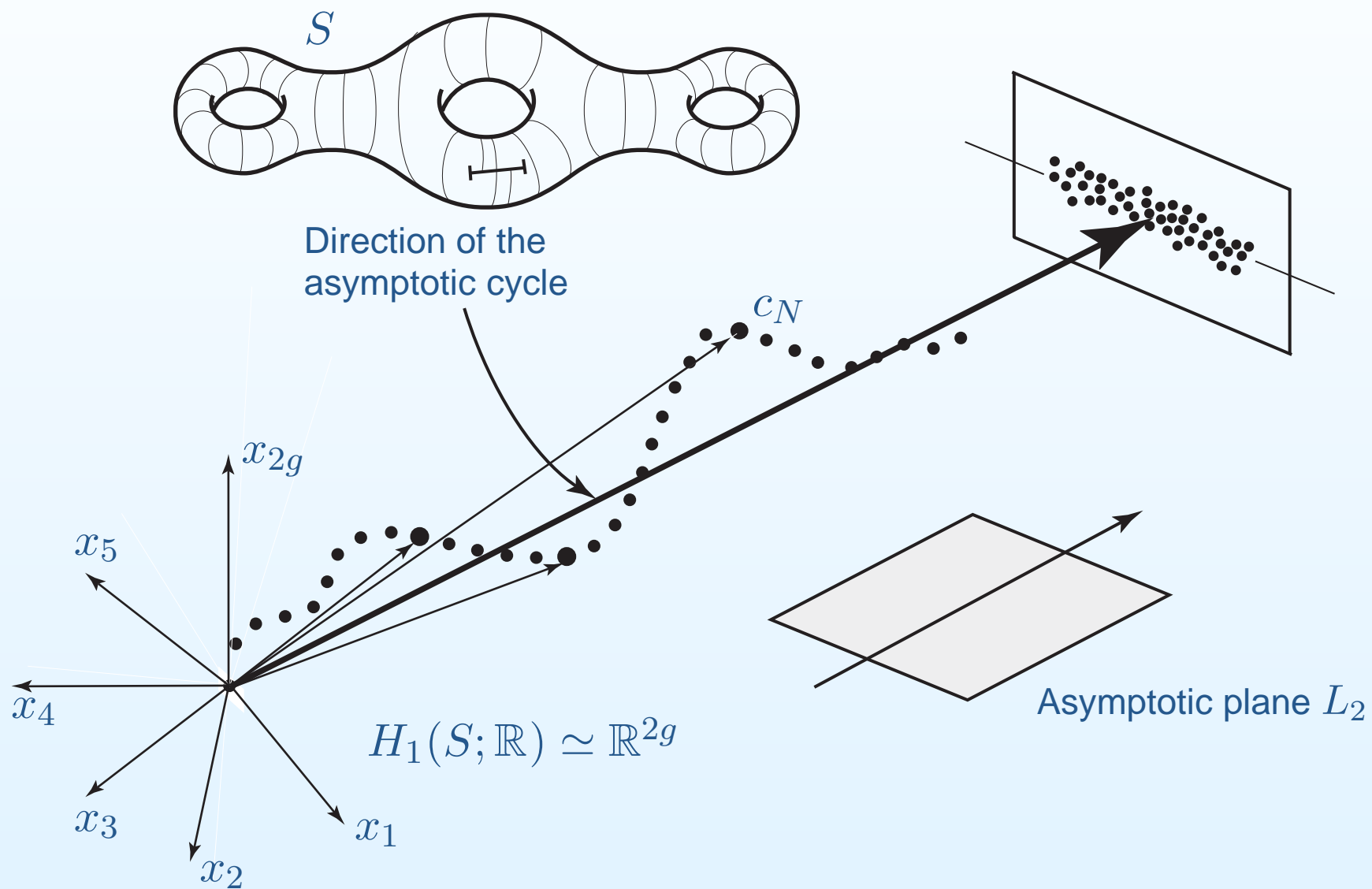

Asymptotic flag: empirical description

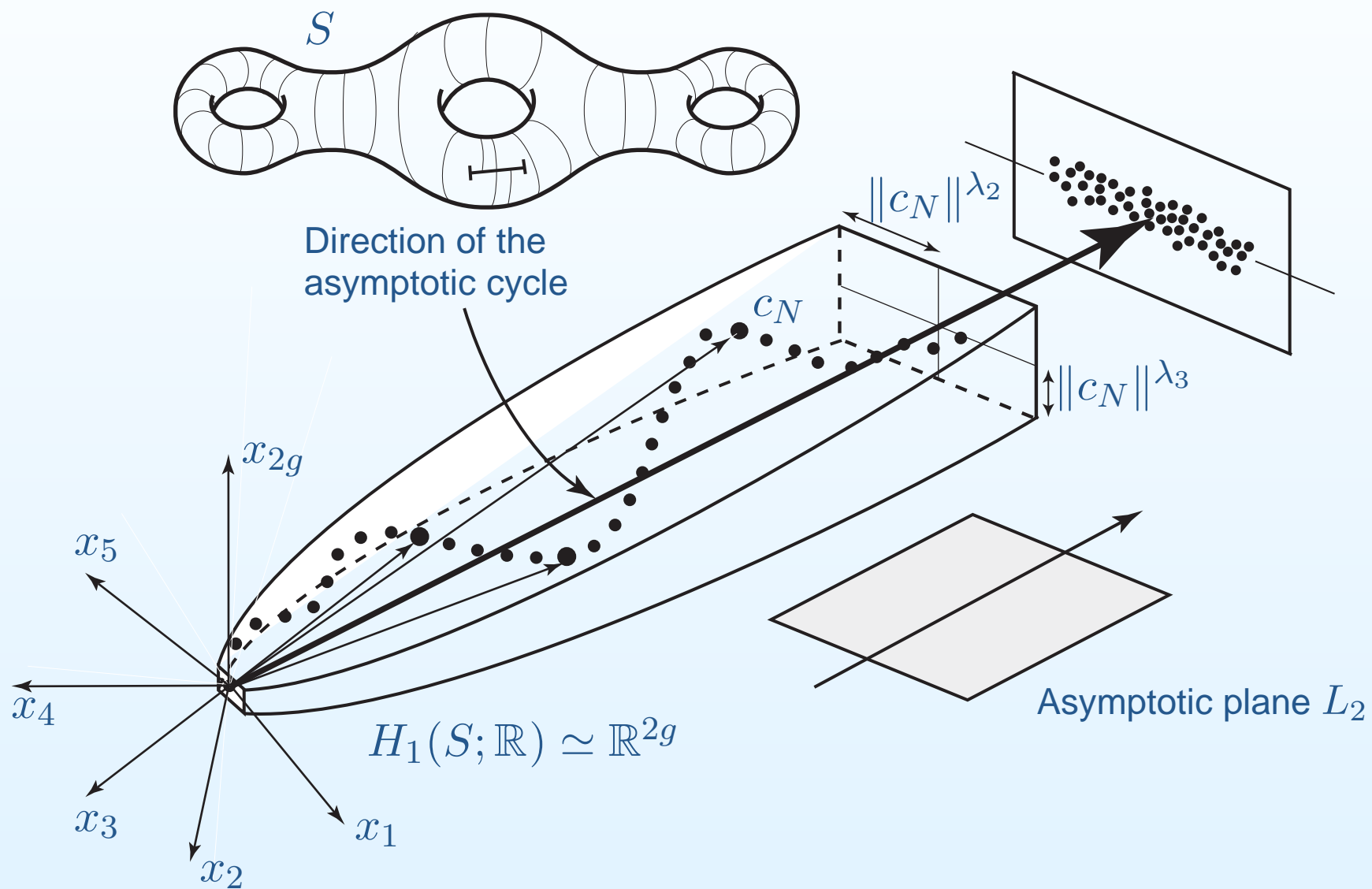

Asymptotic flag

Theorem (A. Z. , 1999) *For almost any surface S in any stratum $\mathcal{H}_1(d_1, \dots, d_n)$ there exists a flag of subspaces $L_1 \subset L_2 \subset \dots \subset L_g \subset H_1(S; \mathbb{R})$ such that for any $j = 1, \dots, g - 1$*

$$\limsup_{N \rightarrow \infty} \frac{\log \text{dist}(c_N, L_j)}{\log N} = \lambda_{j+1}$$

and

$$\text{dist}(c_N, L_g) \leq \text{const},$$

where the constant depends only on S and on the choice of the Euclidean structure in the homology space.

The numbers $1 = \lambda_1 > \lambda_2 > \dots > \lambda_g$ are the top g Lyapunov exponents of the Hodge bundle along the Teichmüller geodesic flow on the corresponding connected component of the stratum $\mathcal{H}(d_1, \dots, d_n)$.

The strict inequalities $\lambda_g > 0$ and $\lambda_2 > \dots > \lambda_g$, and, as a corollary, strict inclusions of the subspaces of the flag, are difficult theorems proved later by Forni (2002) and A. Avila–M. Viana (2007).

Asymptotic flag

Theorem (A. Z. , 1999) *For almost any surface S in any stratum $\mathcal{H}_1(d_1, \dots, d_n)$ there exists a flag of subspaces $L_1 \subset L_2 \subset \dots \subset L_g \subset H_1(S; \mathbb{R})$ such that for any $j = 1, \dots, g - 1$*

$$\limsup_{N \rightarrow \infty} \frac{\log \text{dist}(c_N, L_j)}{\log N} = \lambda_{j+1}$$

and

$$\text{dist}(c_N, L_g) \leq \text{const},$$

where the constant depends only on S and on the choice of the Euclidean structure in the homology space.

The numbers $1 = \lambda_1 > \lambda_2 > \dots > \lambda_g$ are the top g Lyapunov exponents of the Hodge bundle along the Teichmüller geodesic flow on the corresponding connected component of the stratum $\mathcal{H}(d_1, \dots, d_n)$.

The strict inequalities $\lambda_1 > 0$ and $\lambda_2 > \dots > \lambda_g$, and, as a corollary, strict inclusions of the subspaces of the flag, are difficult theorems proved later by Forni (2002) and A. Avila–M. Viana (2007).

Geometric interpretation of multiplicative ergodic theorem: spectrum of “mean monodromy”

Consider a vector bundle endowed with a flat connection over a manifold X^n . Having a flow on the base we can take a fiber of the vector bundle and transport it along a trajectory of the flow. When the trajectory comes close to the starting point we identify the fibers using the connection and we get a linear transformation $\mathcal{A}(x, 1)$ of the fiber; the next time we get a matrix $\mathcal{A}(x, 2)$, etc.

The multiplicative ergodic theorem says that when the flow is ergodic a “*matrix of mean monodromy*” along the flow

$$A_{mean} := \lim_{N \rightarrow \infty} (\mathcal{A}^*(x, N) \cdot \mathcal{A}(x, N))^{\frac{1}{2N}}$$

is well-defined and constant for almost every starting point.

Lyapunov exponents correspond to logarithms of eigenvalues of this “matrix of mean monodromy”.

Geometric interpretation of multiplicative ergodic theorem: spectrum of “mean monodromy”

Consider a vector bundle endowed with a flat connection over a manifold X^n . Having a flow on the base we can take a fiber of the vector bundle and transport it along a trajectory of the flow. When the trajectory comes close to the starting point we identify the fibers using the connection and we get a linear transformation $\mathcal{A}(x, 1)$ of the fiber; the next time we get a matrix $\mathcal{A}(x, 2)$, etc.

The multiplicative ergodic theorem says that when the flow is ergodic a “*matrix of mean monodromy*” along the flow

$$A_{mean} := \lim_{N \rightarrow \infty} (\mathcal{A}^*(x, N) \cdot \mathcal{A}(x, N))^{\frac{1}{2N}}$$

is well-defined and constant for almost every starting point.

Lyapunov exponents correspond to logarithms of eigenvalues of this “matrix of mean monodromy”.

Hodge bundle and Gauss–Manin connection

Consider a natural vector bundle over the stratum with a fiber $H^1(S; \mathbb{R})$ over a “point” (S, ω) , called the *Hodge bundle*. It carries a canonical flat connection called *Gauss–Manin connection*: we have a lattice $H^1(S; \mathbb{Z})$ in each fiber, which tells us how we can locally identify the fibers. Thus, Teichmüller flow on $\mathcal{H}_1(d_1, \dots, d_n)$ defines a multiplicative cocycle acting on fibers of this bundle.

The monodromy matrices of this cocycle are symplectic which implies that the Lyapunov exponents are symmetric:

$$\lambda_1 \geq \lambda_2 \geq \dots \geq \lambda_g \geq -\lambda_g \geq \dots \geq -\lambda_2 \geq -\lambda_1$$

Hodge bundle and Gauss–Manin connection

Consider a natural vector bundle over the stratum with a fiber $H^1(S; \mathbb{R})$ over a “point” (S, ω) , called the *Hodge bundle*. It carries a canonical flat connection called *Gauss–Manin connection*: we have a lattice $H^1(S; \mathbb{Z})$ in each fiber, which tells us how we can locally identify the fibers. Thus, Teichmüller flow on $\mathcal{H}_1(d_1, \dots, d_n)$ defines a multiplicative cocycle acting on fibers of this bundle.

The monodromy matrices of this cocycle are symplectic which implies that the Lyapunov exponents are symmetric:

$$\lambda_1 \geq \lambda_2 \geq \dots \geq \lambda_g \geq -\lambda_g \geq \dots \geq -\lambda_2 \geq -\lambda_1$$

Selected (mostly geometric) results of 1996–2012

- Sum of the Lyapunov exponents of the real Hodge bundle over a Teichmüller curve equals the normalized degree of the determinant bundle (M. Kontsevich).
- Strict inequalities $\lambda_g > 0$ and $\lambda_2 > \dots > \lambda_g$ for all $\mathcal{H}_1(d_1, \dots, d_n)$ (G. Forni and A. Avila–M. Viana correspondingly).
- Classification of connected components of $\mathcal{H}(d_1, \dots, d_n)$ (M. Kontsevich–A. Z.)
- Algorithms for computation of $\text{Vol } \mathcal{H}_1(d_1, \dots, d_n)$ and $\text{Vol } \mathcal{Q}(d_1, \dots, d_n)$ (A. Eskin–A. Okounkov).
- Quadratic asymptotics for the number of closed geodesics on flat surfaces (W. Veech; A. Eskin–H. Masur).
- Expression for Siegel–Veech constants in terms of the volumes of the “principal boundary” strata (A. Eskin–H. Masur–A. Z.)
- Classification of $SL(2, \mathbb{R})$ -invariant submanifolds in genus 2 (C. McMullen)
- Exponential mixing for the Teichmüller flow (A. Avila, S. Gouëzel, J.-C. Yoccoz)
- Infinite series of primitive nonarithmetic Teichmüller curves obtained from cyclic covers (I. Bouw, M. Möller)

Selected (mostly geometric) results of 1996–2012

- Sum of the Lyapunov exponents of the real Hodge bundle over a Teichmüller curve equals the normalized degree of the determinant bundle (M. Kontsevich).
- Strict inequalities $\lambda_g > 0$ and $\lambda_2 > \dots > \lambda_g$ for all $\mathcal{H}_1(d_1, \dots, d_n)$ (G. Forni and A. Avila–M. Viana correspondingly).
- Classification of connected components of $\mathcal{H}(d_1, \dots, d_n)$ (M. Kontsevich–A. Z.)
- Algorithms for computation of $\text{Vol } \mathcal{H}_1(d_1, \dots, d_n)$ and $\text{Vol } \mathcal{Q}(d_1, \dots, d_n)$ (A. Eskin–A. Okounkov).
- Quadratic asymptotics for the number of closed geodesics on flat surfaces (W. Veech; A. Eskin–H. Masur).
- Expression for Siegel–Veech constants in terms of the volumes of the “principal boundary” strata (A. Eskin–H. Masur–A. Z.)
- Classification of $SL(2, \mathbb{R})$ -invariant submanifolds in genus 2 (C. McMullen)
- Exponential mixing for the Teichmüller flow (A. Avila, S. Gouëzel, J.-C. Yoccoz)
- Infinite series of primitive nonarithmetic Teichmüller curves obtained from cyclic covers (I. Bouw, M. Möller)

Selected (mostly geometric) results of 1996–2012

- Sum of the Lyapunov exponents of the real Hodge bundle over a Teichmüller curve equals the normalized degree of the determinant bundle (M. Kontsevich).
- Strict inequalities $\lambda_g > 0$ and $\lambda_2 > \dots > \lambda_g$ for all $\mathcal{H}_1(d_1, \dots, d_n)$ (G. Forni and A. Avila–M. Viana correspondingly).
- Classification of connected components of $\mathcal{H}(d_1, \dots, d_n)$ (M. Kontsevich–A. Z.)
- Algorithms for computation of $\text{Vol } \mathcal{H}_1(d_1, \dots, d_n)$ and $\text{Vol } \mathcal{Q}(d_1, \dots, d_n)$ (A. Eskin–A. Okounkov).
- Quadratic asymptotics for the number of closed geodesics on flat surfaces (W. Veech; A. Eskin–H. Masur).
- Expression for Siegel–Veech constants in terms of the volumes of the “principal boundary” strata (A. Eskin–H. Masur–A. Z.)
- Classification of $SL(2, \mathbb{R})$ -invariant submanifolds in genus 2 (C. McMullen)
- Exponential mixing for the Teichmüller flow (A. Avila, S. Gouëzel, J.-C. Yoccoz)
- Infinite series of primitive nonarithmetic Teichmüller curves obtained from cyclic covers (I. Bouw, M. Möller)

Selected (mostly geometric) results of 1996–2012

- Sum of the Lyapunov exponents of the real Hodge bundle over a Teichmüller curve equals the normalized degree of the determinant bundle (M. Kontsevich).
- Strict inequalities $\lambda_g > 0$ and $\lambda_2 > \dots > \lambda_g$ for all $\mathcal{H}_1(d_1, \dots, d_n)$ (G. Forni and A. Avila–M. Viana correspondingly).
- Classification of connected components of $\mathcal{H}(d_1, \dots, d_n)$ (M. Kontsevich–A. Z.)
- Algorithms for computation of $\text{Vol } \mathcal{H}_1(d_1, \dots, d_n)$ and $\text{Vol } \mathcal{Q}(d_1, \dots, d_n)$ (A. Eskin–A. Okounkov).
- Quadratic asymptotics for the number of closed geodesics on flat surfaces (W. Veech; A. Eskin–H. Masur).
- Expression for Siegel–Veech constants in terms of the volumes of the “principal boundary” strata (A. Eskin–H. Masur–A. Z.)
- Classification of $SL(2, \mathbb{R})$ -invariant submanifolds in genus 2 (C. McMullen)
- Exponential mixing for the Teichmüller flow (A. Avila, S. Gouëzel, J.-C. Yoccoz)
- Infinite series of primitive nonarithmetic Teichmüller curves obtained from cyclic covers (I. Bouw, M. Möller)

Selected (mostly geometric) results of 1996–2012

- Sum of the Lyapunov exponents of the real Hodge bundle over a Teichmüller curve equals the normalized degree of the determinant bundle (M. Kontsevich).
- Strict inequalities $\lambda_g > 0$ and $\lambda_2 > \dots > \lambda_g$ for all $\mathcal{H}_1(d_1, \dots, d_n)$ (G. Forni and A. Avila–M. Viana correspondingly).
- Classification of connected components of $\mathcal{H}(d_1, \dots, d_n)$ (M. Kontsevich–A. Z.)
- Algorithms for computation of $\text{Vol } \mathcal{H}_1(d_1, \dots, d_n)$ and $\text{Vol } \mathcal{Q}(d_1, \dots, d_n)$ (A. Eskin–A. Okounkov).
- Quadratic asymptotics for the number of closed geodesics on flat surfaces (W. Veech; A. Eskin–H. Masur).
- Expression for Siegel–Veech constants in terms of the volumes of the “principal boundary” strata (A. Eskin–H. Masur–A. Z.)
- Classification of $SL(2, \mathbb{R})$ -invariant submanifolds in genus 2 (C. McMullen)
- Exponential mixing for the Teichmüller flow (A. Avila, S. Gouëzel, J.-C. Yoccoz)
- Infinite series of primitive nonarithmetic Teichmüller curves obtained from cyclic covers (I. Bouw, M. Möller)

Selected (mostly geometric) results of 1996–2012

- Sum of the Lyapunov exponents of the real Hodge bundle over a Teichmüller curve equals the normalized degree of the determinant bundle (M. Kontsevich).
- Strict inequalities $\lambda_g > 0$ and $\lambda_2 > \dots > \lambda_g$ for all $\mathcal{H}_1(d_1, \dots, d_n)$ (G. Forni and A. Avila–M. Viana correspondingly).
- Classification of connected components of $\mathcal{H}(d_1, \dots, d_n)$ (M. Kontsevich–A. Z.)
- Algorithms for computation of $\text{Vol } \mathcal{H}_1(d_1, \dots, d_n)$ and $\text{Vol } \mathcal{Q}(d_1, \dots, d_n)$ (A. Eskin–A. Okounkov).
- Quadratic asymptotics for the number of closed geodesics on flat surfaces (W. Veech; A. Eskin–H. Masur).
- Expression for Siegel–Veech constants in terms of the volumes of the “principal boundary” strata (A. Eskin–H. Masur–A. Z.)
- Classification of $SL(2, \mathbb{R})$ -invariant submanifolds in genus 2 (C. McMullen)
- Exponential mixing for the Teichmüller flow (A. Avila, S. Gouëzel, J.-C. Yoccoz)
- Infinite series of primitive nonarithmetic Teichmüller curves obtained from cyclic covers (I. Bouw, M. Möller)

Selected (mostly geometric) results of 1996–2012

- Sum of the Lyapunov exponents of the real Hodge bundle over a Teichmüller curve equals the normalized degree of the determinant bundle (M. Kontsevich).
- Strict inequalities $\lambda_g > 0$ and $\lambda_2 > \dots > \lambda_g$ for all $\mathcal{H}_1(d_1, \dots, d_n)$ (G. Forni and A. Avila–M. Viana correspondingly).
- Classification of connected components of $\mathcal{H}(d_1, \dots, d_n)$ (M. Kontsevich–A. Z.)
- Algorithms for computation of $\text{Vol } \mathcal{H}_1(d_1, \dots, d_n)$ and $\text{Vol } \mathcal{Q}(d_1, \dots, d_n)$ (A. Eskin–A. Okounkov).
- Quadratic asymptotics for the number of closed geodesics on flat surfaces (W. Veech; A. Eskin–H. Masur).
- Expression for Siegel–Veech constants in terms of the volumes of the “principal boundary” strata (A. Eskin–H. Masur–A. Z.)
- Classification of $SL(2, \mathbb{R})$ -invariant submanifolds in genus 2 (C. McMullen)
- Exponential mixing for the Teichmüller flow (A. Avila, S. Gouëzel, J.-C. Yoccoz)
- Infinite series of primitive nonarithmetic Teichmüller curves obtained from cyclic covers (I. Bouw, M. Möller)

Selected (mostly geometric) results of 1996–2012

- Sum of the Lyapunov exponents of the real Hodge bundle over a Teichmüller curve equals the normalized degree of the determinant bundle (M. Kontsevich).
- Strict inequalities $\lambda_g > 0$ and $\lambda_2 > \dots > \lambda_g$ for all $\mathcal{H}_1(d_1, \dots, d_n)$ (G. Forni and A. Avila–M. Viana correspondingly).
- Classification of connected components of $\mathcal{H}(d_1, \dots, d_n)$ (M. Kontsevich–A. Z.)
- Algorithms for computation of $\text{Vol } \mathcal{H}_1(d_1, \dots, d_n)$ and $\text{Vol } \mathcal{Q}(d_1, \dots, d_n)$ (A. Eskin–A. Okounkov).
- Quadratic asymptotics for the number of closed geodesics on flat surfaces (W. Veech; A. Eskin–H. Masur).
- Expression for Siegel–Veech constants in terms of the volumes of the “principal boundary” strata (A. Eskin–H. Masur–A. Z.)
- Classification of $SL(2, \mathbb{R})$ -invariant submanifolds in genus 2 (C. McMullen)
- Exponential mixing for the Teichmüller flow (A. Avila, S. Gouëzel, J.-C. Yoccoz)
- Infinite series of primitive nonarithmetic Teichmüller curves obtained from cyclic covers (I. Bouw, M. Möller)

Selected (mostly geometric) results of 1996–2012

- Sum of the Lyapunov exponents of the real Hodge bundle over a Teichmüller curve equals the normalized degree of the determinant bundle (M. Kontsevich).
- Strict inequalities $\lambda_g > 0$ and $\lambda_2 > \dots > \lambda_g$ for all $\mathcal{H}_1(d_1, \dots, d_n)$ (G. Forni and A. Avila–M. Viana correspondingly).
- Classification of connected components of $\mathcal{H}(d_1, \dots, d_n)$ (M. Kontsevich–A. Z.)
- Algorithms for computation of $\text{Vol } \mathcal{H}_1(d_1, \dots, d_n)$ and $\text{Vol } \mathcal{Q}(d_1, \dots, d_n)$ (A. Eskin–A. Okounkov).
- Quadratic asymptotics for the number of closed geodesics on flat surfaces (W. Veech; A. Eskin–H. Masur).
- Expression for Siegel–Veech constants in terms of the volumes of the “principal boundary” strata (A. Eskin–H. Masur–A. Z.)
- Classification of $SL(2, \mathbb{R})$ -invariant submanifolds in genus 2 (C. McMullen)
- Exponential mixing for the Teichmüller flow (A. Avila, S. Gouëzel, J.-C. Yoccoz)
- Infinite series of primitive nonarithmetic Teichmüller curves obtained from cyclic covers (I. Bouw, M. Möller)

0. Model problem:
diffusion in a periodic
billiard

1. Teichmüller dynamics

2. Translation surfaces
as quadratic differentials

3. Renormalization and
deviation spectrum

2016. State of the art

- Formula for the Lyapunov exponents
- Strata of quadratic differentials
- Kontsevich conjecture
- Invariant measures and orbit closures
- Example of an application: windtree billiards

∞. Challenges and
open directions

2016. State of the art

Formula for the Lyapunov exponents

Theorem (A. Eskin, M. Kontsevich, A. Z., 2014) *The Lyapunov exponents λ_i of the Hodge bundle $H_{\mathbb{R}}^1$ along the Teichmüller flow restricted to an $SL(2, \mathbb{R})$ -invariant suborbifold $\mathcal{L} \subseteq \mathcal{H}_1(d_1, \dots, d_n)$ satisfy:*

$$\lambda_1 + \lambda_2 + \dots + \lambda_g = \frac{1}{12} \cdot \sum_{i=1}^n \frac{d_i(d_i + 2)}{d_i + 1} + \frac{\pi^2}{3} \cdot c_{area}(\mathcal{L}).$$

The proof is based on the initial Kontsevich formula + analytic Riemann-Roch theorem + analysis of $\det \Delta_{flat}$ under degeneration of the flat metric.

Theorem (A. Eskin, H. Masur, A. Z., 2003) *For $\mathcal{L} = \mathcal{H}_1(d_1, \dots, d_n)$ one has*

$$c_{area}(\mathcal{H}_1(d_1, \dots, d_n)) = \sum_{\substack{\text{Combinatorial types} \\ \text{of degenerations}}} (\text{explicit combinatorial factor}) \cdot \frac{\prod_{j=1}^k \text{Vol } \mathcal{H}_1(\text{adjacent simpler strata})}{\text{Vol } \mathcal{H}_1(d_1, \dots, d_n)}.$$

Formula for the Lyapunov exponents

Theorem (A. Eskin, M. Kontsevich, A. Z., 2014) *The Lyapunov exponents λ_i of the Hodge bundle $H_{\mathbb{R}}^1$ along the Teichmüller flow restricted to an $SL(2, \mathbb{R})$ -invariant suborbifold $\mathcal{L} \subseteq \mathcal{H}_1(d_1, \dots, d_n)$ satisfy:*

$$\lambda_1 + \lambda_2 + \dots + \lambda_g = \frac{1}{12} \cdot \sum_{i=1}^n \frac{d_i(d_i + 2)}{d_i + 1} + \frac{\pi^2}{3} \cdot c_{area}(\mathcal{L}).$$

The proof is based on the initial Kontsevich formula + analytic Riemann-Roch theorem + analysis of $\det \Delta_{flat}$ under degeneration of the flat metric.

Theorem (A. Eskin, H. Masur, A. Z., 2003) *For $\mathcal{L} = \mathcal{H}_1(d_1, \dots, d_n)$ one has*

$$c_{area}(\mathcal{H}_1(d_1, \dots, d_n)) = \sum_{\substack{\text{Combinatorial types} \\ \text{of degenerations}}} (\text{explicit combinatorial factor}) \cdot \frac{\prod_{j=1}^k \text{Vol } \mathcal{H}_1(\text{adjacent simpler strata})}{\text{Vol } \mathcal{H}_1(d_1, \dots, d_n)}.$$

Lyapunov exponents for strata of quadratic differentials

Analogous formula exists for the moduli spaces of slightly more general flat surfaces with holonomy $\mathbb{Z}/2\mathbb{Z}$. They correspond to meromorphic quadratic differentials with at most simple poles. For example, the quadratic differential on the picture below lives in the stratum $\mathcal{Q}(1, 1, 1, \underbrace{-1, \dots, -1}_7) =: \mathcal{Q}(1^3, -1^7)$.

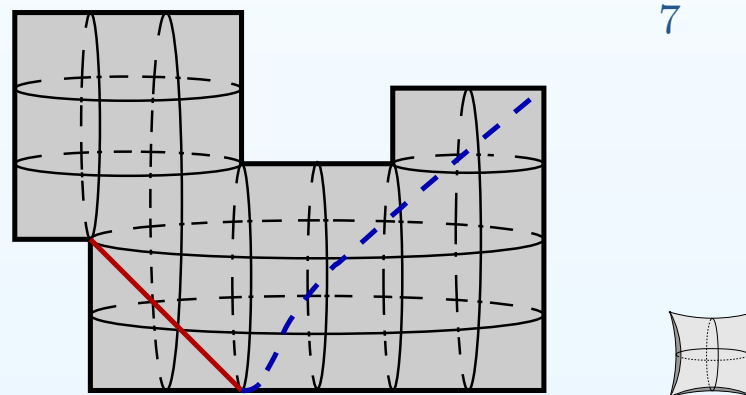

Flat surfaces tiled with unit squares define “integer points” in the corresponding strata. To compute the volume of the corresponding moduli space $\mathcal{Q}_1(d_1, \dots, d_n)$ one needs to compute asymptotics for the number of surfaces with conical singularities $(d_1 + 2)\pi, \dots, (d_n + 2)\pi$ tiled with at most N squares as $N \rightarrow \infty$. When $g = 0$ this number is the *Hurwitz number* of covers $\mathbb{CP}^1 \rightarrow \mathbb{CP}^1$ with a ramification profile, say, as in the picture.

Lyapunov exponents for strata of quadratic differentials

Analogous formula exists for the moduli spaces of slightly more general flat surfaces with holonomy $\mathbb{Z}/2\mathbb{Z}$. They correspond to meromorphic quadratic differentials with at most simple poles. For example, the quadratic differential on the picture below lives in the stratum $\mathcal{Q}(1, 1, 1, \underbrace{-1, \dots, -1}_7) =: \mathcal{Q}(1^3, -1^7)$.

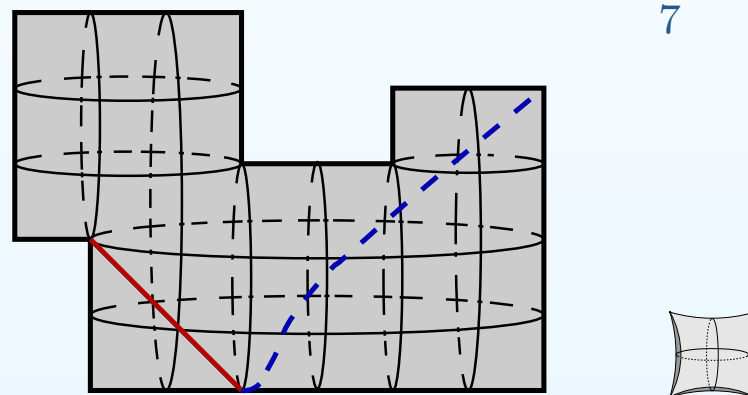

Flat surfaces tiled with unit squares define “integer points” in the corresponding strata. To compute the volume of the corresponding moduli space $\mathcal{Q}_1(d_1, \dots, d_n)$ one needs to compute asymptotics for the number of surfaces with conical singularities $(d_1 + 2)\pi, \dots, (d_n + 2)\pi$ tiled with at most N squares as $N \rightarrow \infty$. When $g = 0$ this number is the *Hurwitz number* of covers $\mathbb{CP}^1 \rightarrow \mathbb{CP}^1$ with a ramification profile, say, as in the picture.

Lyapunov exponents for strata of quadratic differentials



Flat surfaces tiled with unit squares define “integer points” in the corresponding strata. To compute the volume of the corresponding moduli space $\mathcal{Q}_1(d_1, \dots, d_n)$ one needs to compute asymptotics for the number of surfaces with conical singularities $(d_1 + 2)\pi, \dots, (d_n + 2)\pi$ tiled with at most N squares as $N \rightarrow \infty$. When $g = 0$ this number is the *Hurwitz number* of covers $\mathbb{C}P^1 \rightarrow \mathbb{C}P^1$ with a ramification profile, say, as in the picture.

Kontsevich conjecture

$$\text{Let } v(n) := \frac{n!!}{(n+1)!!} \cdot \pi^n \cdot \begin{cases} \pi & \text{when } n \geq -1 \text{ is odd} \\ 2 & \text{when } n \geq 0 \text{ is even} \end{cases}$$

By convention we set $(-1)!! := 0!! := 1$, so $v(-1) = 1$ and $v(0) = 2$.

Theorem (J. Athreya, A. Eskin, A. Z., 2014 ; conjectured by M. Kontsevich about 2003) *The volume of any stratum $\mathcal{Q}_1(d_1, \dots, d_k)$ of meromorphic quadratic differentials with at most simple poles on $\mathbb{C}P^1$ (i.e. when $d_i \in \{-1; 0\} \cup \mathbb{N}$ for $i = 1, \dots, k$, and $\sum_{i=1}^k d_i = -4$) is equal to*

$$\text{Vol } \mathcal{Q}_1(d_1, \dots, d_k) = 2\pi \cdot \prod_{i=1}^k v(d_i).$$

The loci in the moduli spaces of quadratic differentials obtained as orbit closures of flat surfaces arising from wind-tree models are often covers of strata in genus zero. Knowing volumes of these strata we can often compute the Siegel–Veech constants of the covering loci, and, as a result, compute (or estimate) their Lyapunov exponents.

Kontsevich conjecture

$$\text{Let } v(n) := \frac{n!!}{(n+1)!!} \cdot \pi^n \cdot \begin{cases} \pi & \text{when } n \geq -1 \text{ is odd} \\ 2 & \text{when } n \geq 0 \text{ is even} \end{cases}$$

By convention we set $(-1)!! := 0!! := 1$, so $v(-1) = 1$ and $v(0) = 2$.

Theorem (J. Athreya, A. Eskin, A. Z., 2014 ; conjectured by M. Kontsevich about 2003) *The volume of any stratum $\mathcal{Q}_1(d_1, \dots, d_k)$ of meromorphic quadratic differentials with at most simple poles on $\mathbb{C}P^1$ (i.e. when $d_i \in \{-1; 0\} \cup \mathbb{N}$ for $i = 1, \dots, k$, and $\sum_{i=1}^k d_i = -4$) is equal to*

$$\text{Vol } \mathcal{Q}_1(d_1, \dots, d_k) = 2\pi \cdot \prod_{i=1}^k v(d_i).$$

The loci in the moduli spaces of quadratic differentials obtained as orbit closures of flat surfaces arising from wind-tree models are often covers of strata in genus zero. Knowing volumes of these strata we can often compute the Siegel–Veech constants of the covering loci, and, as a result, compute (or estimate) their Lyapunov exponents.

Kontsevich conjecture

$$\text{Let } v(n) := \frac{n!!}{(n+1)!!} \cdot \pi^n \cdot \begin{cases} \pi & \text{when } n \geq -1 \text{ is odd} \\ 2 & \text{when } n \geq 0 \text{ is even} \end{cases}$$

By convention we set $(-1)!! := 0!! := 1$, so $v(-1) = 1$ and $v(0) = 2$.

Theorem (J. Athreya, A. Eskin, A. Z., 2014 ; conjectured by M. Kontsevich about 2003) *The volume of any stratum $\mathcal{Q}_1(d_1, \dots, d_k)$ of meromorphic quadratic differentials with at most simple poles on $\mathbb{C}P^1$ (i.e. when $d_i \in \{-1; 0\} \cup \mathbb{N}$ for $i = 1, \dots, k$, and $\sum_{i=1}^k d_i = -4$) is equal to*

$$\text{Vol } \mathcal{Q}_1(d_1, \dots, d_k) = 2\pi \cdot \prod_{i=1}^k v(d_i).$$

The loci in the moduli spaces of quadratic differentials obtained as orbit closures of flat surfaces arising from wind-tree models are often covers of strata in genus zero. Knowing volumes of these strata we can often compute the Siegel–Veech constants of the covering loci, and, as a result, compute (or estimate) their Lyapunov exponents.

Invariant measures and orbit closures

Magic Wand Theorem (A. Eskin–M. Mirzakhani–A. Mohammadi, 2014).

The closure of any $SL(2, \mathbb{R})$ -orbit is a suborbifold. In period coordinates any $SL(2, \mathbb{R})$ -suborbifold is represented by an affine subspace.

Any ergodic $SL(2, \mathbb{R})$ -invariant measure is supported on a suborbifold. In period coordinates this suborbifold is represented by an affine subspace, and the invariant measure is just a usual affine measure on this affine subspace.

Theorem (S. Filip, 2014) *Any $SL(2, \mathbb{R})$ -invariant orbifold is, actually, a complex orbifold.*

Technology (A. Wright, 2014) *Methods of construction of orbit closures.*

Developement (C. McMullen–R. Mukamel–A. Wright, in progress)

Examples of $SL(2, \mathbb{R})$ -invariant orbifolds (generalizing Bouw–Möller curves).

Theorem (J. Chaika–A. Eskin, 2014). *For any flat surface S almost all vertical directions define a Lyapunov-generic point in the orbit closure $\overline{SL(2, \mathbb{R}) \cdot S}$.*

Developement (A. Eskin–M. Kontsevich–A. Z.; G. Farkas–R. Phandaripande; M. Bainbridge–D. Chen–Q. Gendron–S. Grushevsky–M. Möller, in progress) *Better understanding of an adequate compactification of strata.*

Invariant measures and orbit closures

Magic Wand Theorem (A. Eskin–M. Mirzakhani–A. Mohammadi, 2014).

The closure of any $SL(2, \mathbb{R})$ -orbit is a suborbifold. In period coordinates any $SL(2, \mathbb{R})$ -suborbifold is represented by an affine subspace.

Any ergodic $SL(2, \mathbb{R})$ -invariant measure is supported on a suborbifold. In period coordinates this suborbifold is represented by an affine subspace, and the invariant measure is just a usual affine measure on this affine subspace.

Theorem (S. Filip, 2014) *Any $SL(2, \mathbb{R})$ -invariant orbifold is, actually, a complex orbifold.*

Technology (A. Wright, 2014) *Methods of construction of orbit closures.*

Developement (C. McMullen–R. Mukamel–A. Wright, in progress)

Examples of $SL(2, \mathbb{R})$ -invariant orbifolds (generalizing Bouw–Möller curves).

Theorem (J. Chaika–A. Eskin, 2014). *For any flat surface S almost all vertical directions define a Lyapunov-generic point in the orbit closure $\overline{SL(2, \mathbb{R}) \cdot S}$.*

Developement (A. Eskin–M. Kontsevich–A. Z.; G. Farkas–R. Phandaripande; M. Bainbridge–D. Chen–Q. Gendron–S. Grushevsky–M. Möller, in progress) *Better understanding of an adequate compactification of strata.*

Invariant measures and orbit closures

Magic Wand Theorem (A. Eskin–M. Mirzakhani–A. Mohammadi, 2014).

The closure of any $SL(2, \mathbb{R})$ -orbit is a suborbifold. In period coordinates any $SL(2, \mathbb{R})$ -suborbifold is represented by an affine subspace.

Any ergodic $SL(2, \mathbb{R})$ -invariant measure is supported on a suborbifold. In period coordinates this suborbifold is represented by an affine subspace, and the invariant measure is just a usual affine measure on this affine subspace.

Theorem (S. Filip, 2014) *Any $SL(2, \mathbb{R})$ -invariant orbifold is, actually, a complex orbifold.*

Technology (A. Wright, 2014) *Methods of construction of orbit closures.*

Developement (C. McMullen–R. Mukamel–A. Wright, in progress)

Examples of $SL(2, \mathbb{R})$ -invariant orbifolds (generalizing Bouw–Möller curves).

Theorem (J. Chaika–A. Eskin, 2014). *For any flat surface S almost all vertical directions define a Lyapunov-generic point in the orbit closure $\overline{SL(2, \mathbb{R}) \cdot S}$.*

Developement (A. Eskin–M. Kontsevich–A. Z.; G. Farkas–R. Phandaripande; M. Bainbridge–D. Chen–Q. Gendron–S. Grushevsky–M. Möller, in progress) *Better understanding of an adequate compactification of strata.*

Invariant measures and orbit closures

Magic Wand Theorem (A. Eskin–M. Mirzakhani–A. Mohammadi, 2014).

The closure of any $SL(2, \mathbb{R})$ -orbit is a suborbifold. In period coordinates any $SL(2, \mathbb{R})$ -suborbifold is represented by an affine subspace.

Any ergodic $SL(2, \mathbb{R})$ -invariant measure is supported on a suborbifold. In period coordinates this suborbifold is represented by an affine subspace, and the invariant measure is just a usual affine measure on this affine subspace.

Theorem (S. Filip, 2014) *Any $SL(2, \mathbb{R})$ -invariant orbifold is, actually, a complex orbifold.*

Technology (A. Wright, 2014) *Methods of construction of orbit closures.*

Developement (C. McMullen–R. Mukamel–A. Wright, in progress)

Examples of $SL(2, \mathbb{R})$ -invariant orbifolds (generalizing Bouw–Möller curves).

Theorem (J. Chaika–A. Eskin, 2014). *For any flat surface S almost all vertical directions define a Lyapunov-generic point in the orbit closure $\overline{SL(2, \mathbb{R}) \cdot S}$.*

Developement (A. Eskin–M. Kontsevich–A. Z.; G. Farkas–R. Phandaripande; M. Bainbridge–D. Chen–Q. Gendron–S. Grushevsky–M. Möller, in progress) *Better understanding of an adequate compactification of strata.*

Invariant measures and orbit closures

Magic Wand Theorem (A. Eskin–M. Mirzakhani–A. Mohammadi, 2014).

The closure of any $SL(2, \mathbb{R})$ -orbit is a suborbifold. In period coordinates any $SL(2, \mathbb{R})$ -suborbifold is represented by an affine subspace.

Any ergodic $SL(2, \mathbb{R})$ -invariant measure is supported on a suborbifold. In period coordinates this suborbifold is represented by an affine subspace, and the invariant measure is just a usual affine measure on this affine subspace.

Theorem (S. Filip, 2014) *Any $SL(2, \mathbb{R})$ -invariant orbifold is, actually, a complex orbifold.*

Technology (A. Wright, 2014) *Methods of construction of orbit closures.*

Developement (C. McMullen–R. Mukamel–A. Wright, in progress)

Examples of $SL(2, \mathbb{R})$ -invariant orbifolds (generalizing Bouw–Möller curves).

Theorem (J. Chaika–A. Eskin, 2014). *For any flat surface S almost all vertical directions define a Lyapunov-generic point in the orbit closure $\overline{SL(2, \mathbb{R}) \cdot S}$.*

Developement (A. Eskin–M. Kontsevich–A. Z.; G. Farkas–R. Phandaripande; M. Bainbridge–D. Chen–Q. Gendron–S. Grushevsky–M. Möller, in progress) *Better understanding of an adequate compactification of strata.*

Invariant measures and orbit closures

Magic Wand Theorem (A. Eskin–M. Mirzakhani–A. Mohammadi, 2014).

The closure of any $SL(2, \mathbb{R})$ -orbit is a suborbifold. In period coordinates any $SL(2, \mathbb{R})$ -suborbifold is represented by an affine subspace.

Any ergodic $SL(2, \mathbb{R})$ -invariant measure is supported on a suborbifold. In period coordinates this suborbifold is represented by an affine subspace, and the invariant measure is just a usual affine measure on this affine subspace.

Theorem (S. Filip, 2014) *Any $SL(2, \mathbb{R})$ -invariant orbifold is, actually, a complex orbifold.*

Technology (A. Wright, 2014) *Methods of construction of orbit closures.*

Developement (C. McMullen–R. Mukamel–A. Wright, in progress)

Examples of $SL(2, \mathbb{R})$ -invariant orbifolds (generalizing Bouw–Möller curves).

Theorem (J. Chaika–A. Eskin, 2014). *For any flat surface S almost all vertical directions define a Lyapunov-generic point in the orbit closure $\overline{SL(2, \mathbb{R}) \cdot S}$.*

Developement (A. Eskin–M. Kontsevich–A. Z.; G. Farkas–R. Phandaripande; M. Bainbridge–D. Chen–Q. Gendron–S. Grushevsky–M. Möller, in progress) *Better understanding of an adequate compactification of strata.*

Example of an application: windtree billiards

Diffusion rate of any given generalized “windtree billiard” with rational polygonal obstacles (schematic solution)

- Detect all symmetries of the induced flat surface;
- Find the $SL(2, \mathbb{R})$ -invariant locus \mathcal{L} in the moduli space of quadratic differentials corresponding to these symmetries;
- Prove that the $SL(2, \mathbb{R})$ -orbit closure of S_0 is indeed \mathcal{L} ;
- Compute or estimate the Lyapunov exponents $\lambda(h)$ and $\lambda(v)$.

Currently we do not have a slightest idea on how to approach the problem when the periodic obstacles are irrational or even when periodic rectangular obstacles are twisted with respect to the axes of the square lattice by an angle $\pi \cdot \alpha$ with $\alpha \notin \mathbb{Q}$.

Question. *What diffusion rate has a windtree billiard with generic (in any reasonable sense) obstacles? Is it, by any chance, $\frac{1}{2}$?*

Example of an application: windtree billiards

Diffusion rate of any given generalized “windtree billiard” with rational polygonal obstacles (schematic solution)

- Detect all symmetries of the induced flat surface;
- Find the $SL(2, \mathbb{R})$ -invariant locus \mathcal{L} in the moduli space of quadratic differentials corresponding to these symmetries;
- Prove that the $SL(2, \mathbb{R})$ -orbit closure of S_0 is indeed \mathcal{L} ;
- Compute or estimate the Lyapunov exponents $\lambda(h)$ and $\lambda(v)$.

Currently we do not have a slightest idea on how to approach the problem when the periodic obstacles are irrational or even when periodic rectangular obstacles are twisted with respect to the axes of the square lattice by an angle $\pi \cdot \alpha$ with $\alpha \notin \mathbb{Q}$.

Question. *What diffusion rate has a windtree billiard with generic (in any reasonable sense) obstacles? Is it, by any chance, $\frac{1}{2}$?*

0. Model problem:
diffusion in a periodic
billiard

1. Teichmüller dynamics

2. Translation surfaces
as quadratic differentials

3. Renormalization and
deviation spectrum

2016. State of the art

**∞. Challenges and
open directions**

- Challenges and open directions
- Joueurs de billard

∞. Challenges and open directions

Challenges and open directions

- Study and classify all $GL(2, \mathbb{R})$ -invariant suborbifolds in $\mathcal{H}(d_1, \dots, d_n)$. (C. McMullen, M. Mirzakhani, R. Mukamel, and A. Wright have recently found interesting $SL(2, \mathbb{R})$ -invariant subvarieties generalizing Bouw–Möller curves.)
- Study extremal properties of the “curvature” of the Lyapunov subbundles compared to holomorphic subbundles of the Hodge bundle. Estimate individual Lyapunov exponents (details in the talk of M. Möller).
- Prove conjectural formulae for asymptotics of volumes, and of Siegel–Veech constants when $g \rightarrow \infty$. (Partial results are already obtained by D. Chen–M. Möller–D. Zagier, and by A. Z. (both in progress))
- Express $c_{area}(\mathcal{L})$ in terms of an appropriate intersection theory (in the spirit of ELSV-formula for Hurwitz numbers or Mirzakhani formula for WP-volumes).
- Study dynamics of the Hodge bundle over other families of compact varieties (some experimental results for families of Calabi–Yau varieties are recently obtained by M. Kontsevich; some results for families of K3 surfaces were obtained by S. Filip). Are there other dynamical systems, which admit renormalization leading to dynamics on families of complex varieties?

Challenges and open directions

- Study and classify all $GL(2, \mathbb{R})$ -invariant suborbifolds in $\mathcal{H}(d_1, \dots, d_n)$. (C. McMullen, M. Mirzakhani, R. Mukamel, and A. Wright have recently found interesting $SL(2, \mathbb{R})$ -invariant subvarieties generalizing Bouw–Möller curves.)
- Study extremal properties of the “curvature” of the Lyapunov subbundles compared to holomorphic subbundles of the Hodge bundle. Estimate individual Lyapunov exponents (details in the talk of M. Möller).
- Prove conjectural formulae for asymptotics of volumes, and of Siegel–Veech constants when $g \rightarrow \infty$. (Partial results are already obtained by D. Chen–M. Möller–D. Zagier, and by A. Z. (both in progress))
- Express $c_{area}(\mathcal{L})$ in terms of an appropriate intersection theory (in the spirit of ELSV-formula for Hurwitz numbers or Mirzakhani formula for WP-volumes).
- Study dynamics of the Hodge bundle over other families of compact varieties (some experimental results for families of Calabi–Yau varieties are recently obtained by M. Kontsevich; some results for families of K3 surfaces were obtained by S. Filip). Are there other dynamical systems, which admit renormalization leading to dynamics on families of complex varieties?

Challenges and open directions

- Study and classify all $GL(2, \mathbb{R})$ -invariant suborbifolds in $\mathcal{H}(d_1, \dots, d_n)$. (C. McMullen, M. Mirzakhani, R. Mukamel, and A. Wright have recently found interesting $SL(2, \mathbb{R})$ -invariant subvarieties generalizing Bouw–Möller curves.)
- Study extremal properties of the “curvature” of the Lyapunov subbundles compared to holomorphic subbundles of the Hodge bundle. Estimate individual Lyapunov exponents (details in the talk of M. Möller).
- Prove conjectural formulae for asymptotics of volumes, and of Siegel–Veech constants when $g \rightarrow \infty$. (Partial results are already obtained by D. Chen–M. Möller–D. Zagier, and by A. Z. (both in progress))
- Express $c_{area}(\mathcal{L})$ in terms of an appropriate intersection theory (in the spirit of ELSV-formula for Hurwitz numbers or Mirzakhani formula for WP-volumes).
- Study dynamics of the Hodge bundle over other families of compact varieties (some experimental results for families of Calabi–Yau varieties are recently obtained by M. Kontsevich; some results for families of K3 surfaces were obtained by S. Filip). Are there other dynamical systems, which admit renormalization leading to dynamics on families of complex varieties?

Challenges and open directions

- Study and classify all $GL(2, \mathbb{R})$ -invariant suborbifolds in $\mathcal{H}(d_1, \dots, d_n)$. (C. McMullen, M. Mirzakhani, R. Mukamel, and A. Wright have recently found interesting $SL(2, \mathbb{R})$ -invariant subvarieties generalizing Bouw–Möller curves.)
- Study extremal properties of the “curvature” of the Lyapunov subbundles compared to holomorphic subbundles of the Hodge bundle. Estimate individual Lyapunov exponents (details in the talk of M. Möller).
- Prove conjectural formulae for asymptotics of volumes, and of Siegel–Veech constants when $g \rightarrow \infty$. (Partial results are already obtained by D. Chen–M. Möller–D. Zagier, and by A. Z. (both in progress))
- Express $c_{area}(\mathcal{L})$ in terms of an appropriate intersection theory (in the spirit of ELSV-formula for Hurwitz numbers or Mirzakhani formula for WP-volumes).
- Study dynamics of the Hodge bundle over other families of compact varieties (some experimental results for families of Calabi–Yau varieties are recently obtained by M. Kontsevich; some results for families of K3 surfaces were obtained by S. Filip). Are there other dynamical systems, which admit renormalization leading to dynamics on families of complex varieties?

Challenges and open directions

- Study and classify all $GL(2, \mathbb{R})$ -invariant suborbifolds in $\mathcal{H}(d_1, \dots, d_n)$. (C. McMullen, M. Mirzakhani, R. Mukamel, and A. Wright have recently found interesting $SL(2, \mathbb{R})$ -invariant subvarieties generalizing Bouw–Möller curves.)
- Study extremal properties of the “curvature” of the Lyapunov subbundles compared to holomorphic subbundles of the Hodge bundle. Estimate individual Lyapunov exponents (details in the talk of M. Möller).
- Prove conjectural formulae for asymptotics of volumes, and of Siegel–Veech constants when $g \rightarrow \infty$. (Partial results are already obtained by D. Chen–M. Möller–D. Zagier, and by A. Z. (both in progress))
- Express $c_{area}(\mathcal{L})$ in terms of an appropriate intersection theory (in the spirit of ELSV-formula for Hurwitz numbers or Mirzakhani formula for WP-volumes).
- Study dynamics of the Hodge bundle over other families of compact varieties (some experimental results for families of Calabi–Yau varieties are recently obtained by M. Kontsevich; some results for families of K3 surfaces were obtained by S. Filip). Are there other dynamical systems, which admit renormalization leading to dynamics on families of complex varieties?

Billiard in a polygon: artistic image



Varvara Stepanova. Joueurs de billard. Thyssen Museum, Madrid