

On the Teichmüller tower of mapping class groups

Allen Hatcher, Pierre Lochak and Leila Schneps

Abstract. Let \widehat{GT}^1 be the subgroup of the Grothendieck-Teichmüller group having λ -component equal to 1. We define a subgroup Λ of \widehat{GT}^1 by adding one additional defining relation to the definition of \widehat{GT}^1 , and show that Λ acts on the tower of profinite mapping class groups $\widehat{\Gamma}_{g,n}^m$ for all $g, n, m \geq 0$, respecting all the natural arrows $\widehat{\Gamma}_{g',n'}^{m'} \rightarrow \widehat{\Gamma}_{g,n}^m$ coming from cutting out a topological surface of genus g' with n' punctures and m' boundary components inside one of genus g with n punctures and m boundary components. The proof that these homomorphisms are respected is an easy consequence of a certain *local inertia conjugation property* of the action of Λ .

§1. Introduction and results.

In this paper, we exhibit a large subgroup of the Grothendieck-Teichmüller group which has the following property: it acts on the profinite mapping class groups $\widehat{\Gamma}_{g,n}^m$ for all $g, n, m \geq 0$ (recall that these groups, also called Teichmüller modular groups in an algebraic context, are isomorphic to fundamental groups of moduli spaces of curves with a given finite number of marked points and boundary components). We uncover and emphasize the fact that this action, which extends the known action in the genus 0 case, respects certain fundamental homomorphisms between the mapping class groups, namely *those naturally induced by inclusions of the associated subsurfaces*. Before stating the results, let us informally recall some mathematical facts and historical background.

The history of the main character, namely the Grothendieck-Teichmüller group \widehat{GT} is still a short one. A fascinating watermark version of it can be found in Grothendieck's *Esquisse d'un programme* (see [GGA] and the comments of V.G.Drinfeld in [D]). Let us briefly sketch our version of this history. A *Teichmüller tower* consists of a collection of (algebraic, i.e. profinite) mapping class groups linked by certain natural homomorphisms coming from corresponding homomorphisms between the associated moduli spaces. The *geometric (outer) automorphism group* of such a Teichmüller tower is the collection of tuples of automorphisms of each of the mapping class groups which commute, up to inner automorphism, with the homomorphisms of the tower. Until now, only Teichmüller towers consisting of mapping class groups in genus zero (or braid groups) have been studied. The *ideal Teichmüller tower* should consist of the collection of the (algebraic, i.e. profinite) fundamental groups $\widehat{\Gamma}_{g,n}^m$ of the moduli spaces $\mathcal{M}_{g,n}^m$ of genus g curves with n marked

points and m boundary components for all possible types (g, n, m) , linked by homomorphisms coming from *all possible* natural morphisms between the corresponding moduli spaces. The present article does not claim to give a full definition of the ideal Teichmüller tower, but it takes a fundamental step in that direction by introducing the two following new features: *considering a tower of mapping class groups in all genera, and equipping it with the “subsurface-inclusion homomorphisms”*. These homomorphisms are induced by morphisms of the moduli spaces which send a given space to a divisor at infinity of another one of larger dimension. They are very natural, because the divisor at infinity of the completion of any $\mathcal{M}_{g,n}^m$ is (essentially, i.e. up to finite morphisms) “made of” copies of other $\mathcal{M}_{g',n'}^{m'}$, of strictly lower dimensions (in fact, the stable completion of any $\mathcal{M}_{g,n}^m$ has a stratified structure, with $\mathcal{M}_{g,n}^m$ itself as the only open stratum). Thus, these homomorphisms should certainly be included in any definition of an ideal Teichmüller tower. The group which truly deserves the name of “Grothendieck-Teichmüller” should be the automorphism group of the ideal geometric Teichmüller tower, consisting of all profinite mapping class groups and *all possible* natural homomorphisms reflecting important geometric morphisms between the moduli spaces.

In the *Esquisse*, Grothendieck suggests that the geometric automorphism group of a Teichmüller tower can be in some sense “explicitly” described. Furthermore, he conjectures that such an automorphism group must depend in fact only on the first two levels (*les deux premiers étages*), i.e. on the fundamental groups of the moduli spaces of types (g, n, m) with $3g - 3 + (n + m)$ equal to 1 or 2. Part of this “two-level philosophy” is of essentially geometric and even topological nature, and this is where one first comes across the work of Thurston on surfaces and its bearing on the study of the moduli spaces (viewed as real orbifolds) and their (topological) fundamental groups (see [L] for a more detailed discussion). Thus, the first striking piece of news is the fact that the group of geometric automorphisms of a Teichmüller tower should afford a reasonably explicit description. This is a very rare and precious phenomenon. The first result in this direction is that the geometric automorphism group of the Teichmüller tower of mapping class groups in genus zero linked by subsurface-inclusion homomorphisms is equal to the original Grothendieck-Teichmüller group \widehat{GT} defined by Drinfel’d in [D]. This follows from the computation, in [LS], of the automorphism group of a certain tower of braid groups with specific linking homomorphisms; the geometric aspect of this tower was not explored in [LS] but the tower constructed there is essentially equivalent to the genus zero Teichmüller tower. In the present article we compute the geometric automorphism group Λ of a tower consisting of all the $\widehat{\Gamma}_{g,n}^m$ and all subsurface-inclusion homomorphisms, and its action restricts to the genus zero Teichmüller tower; thus Λ naturally occurs as a subgroup of \widehat{GT} . Similarly, Λ should contain (a large subgroup of) the *ideal Grothendieck-Teichmüller group*, geometric automorphism group of the ideal Teichmüller tower.

A major incentive for studying the Grothendieck-Teichmüller group is its close connection with the absolute Galois group $G_{\mathbb{Q}}$ of \mathbb{Q} . The moduli spaces $\mathcal{M}_{g,n}^m$ are defined over \mathbb{Q} , and this gives rise to an outer action of $G_{\mathbb{Q}}$ on the algebraic parts $\widehat{\Gamma}_{g,n}^m$ of their fundamental groups, justified by generalizing to stacks the Grothendieck short exact sequence for fundamental groups (see [O]). In the ideal Teichmüller tower, all the morphisms between moduli spaces should be \mathbb{Q} -morphisms (this is the case for the morphisms studied in the present article). This would ensure a $G_{\mathbb{Q}}$ -action on all the $\widehat{\Gamma}_{g,n}^m$, respecting all the morphisms of the ideal Teichmüller tower, thus giving rise to a natural homomorphism of $G_{\mathbb{Q}}$ into the geometric automorphism group of the ideal tower (which can be shown to be injective via the Belyi three-point theorem). Thus the interesting question of the possible equality of the ideal Grothendieck-Teichmüller group with $G_{\mathbb{Q}}$ arises. This interpretation of the usual group \widehat{GT} makes it obvious that it contains $G_{\mathbb{Q}}$. The same is true of the group Λ defined in this article – except that because of certain assumptions made about the type of the action, it is actually a certain large subgroup of $G_{\mathbb{Q}}$ which is included in Λ , namely the absolute Galois group G_K of the extension K of \mathbb{Q} obtained by adding all n -th roots of unity and of 2 for all $n \geq 1$. An actual proof of the fact that Λ contains this large group follows as a corollary of the results of [NS] (see also [LNS]). Indeed, in that article, a group \mathbb{F} is defined which contains $G_{\mathbb{Q}}$, and it possesses a subgroup $\widetilde{\mathbb{F}}$ such that $G_K \subset \widetilde{\mathbb{F}} \subset \Lambda$. Such results are far from obvious from the definitions of these groups as subsets of elements of profinite groups satisfying combinatorial properties; the first proof that $G_{\mathbb{Q}} \hookrightarrow \widehat{GT}$, which used the combinatorial definition of \widehat{GT} , was given by Ihara in [I].

Let us now proceed to a statement of our main results. We first need a little notation and background. Let $\Sigma_{g,n}^m$ denote a topological surface with genus $g \geq 0$, $n \geq 0$ punctures, and $m \geq 0$ boundary components, i.e. such that filling in the n punctures gives a compact surface with m boundary components homeomorphic to circles. We write $\Sigma_{g,n}$ when $m = 0$, Σ_g^m when $n = 0$, and Σ_g when $n = m = 0$. The associated *pure mapping class group*, denoted $\Gamma_{g,n}^m$, is defined to be the group of classes of orientation-preserving diffeomorphisms of $\Sigma_{g,n}^m$ fixing the boundaries pointwise, modulo those which are isotopic to the identity fixing the boundaries pointwise. The term “pure” indicates the fact that we do not consider classes of diffeomorphisms permuting the punctures or boundary components. The group $\Gamma_{g,n}^m$ is generated by Dehn twists a along simple closed curves α on $\Sigma_{g,n}^m$ (cf. [B] for a basic reference on this material.) We use corresponding Greek and Roman letters for corresponding loops and Dehn twists. Generally, we write Σ for such a surface and $\Gamma(\Sigma)$ for its mapping class group; we say that Σ is of type (g, n, m) , and use hats to indicate profinite completions. As for the Σ 's, we write $\Gamma_{g,n} = \Gamma_{g,n}^0$, $\Gamma_g^m = \Gamma_{g,0}^m$ and $\Gamma_g = \Gamma_{g,0}$. The Dehn twists along the boundary components are obviously central in $\Gamma_{g,n}^m$, and we have the exact sequence

$$1 \rightarrow \mathbb{Z}^m \rightarrow \Gamma_{g,n}^m \rightarrow \Gamma_{g,n+m} \rightarrow 1,$$

corresponding to collapsing the boundary components of $\Sigma_{g,n}^m$ to punctures.

Definition. Let \widehat{GT}^1 be the set of elements f in the derived subgroup \widehat{F}'_2 of \widehat{F}_2 such that $x \mapsto x$ and $y \mapsto f^{-1}yf$ extends to an automorphism F_f of \widehat{F}_2 , and which furthermore satisfy the following three relations:

- (I) $f(a_2^2, a_1^2)f(a_1^2, a_2^2) = 1$ in $\widehat{\Gamma}_1^1$, where α_1 and α_2 are as in figure 1(a);
- (II) $f(b_3, b_1)f(b_2, b_3)f(b_1, b_2) = 1$ in $\widehat{\Gamma}_0^4$, where β_1, β_2 and β_3 are as in figure 1(b);
- (III) $f(b_3, b_4)f(b_5, b_1)f(b_2, b_3)f(b_4, b_5)f(b_1, b_2) = 1$ in $\widehat{\Gamma}_0^5$, where the β_i are as in figure 1(c).

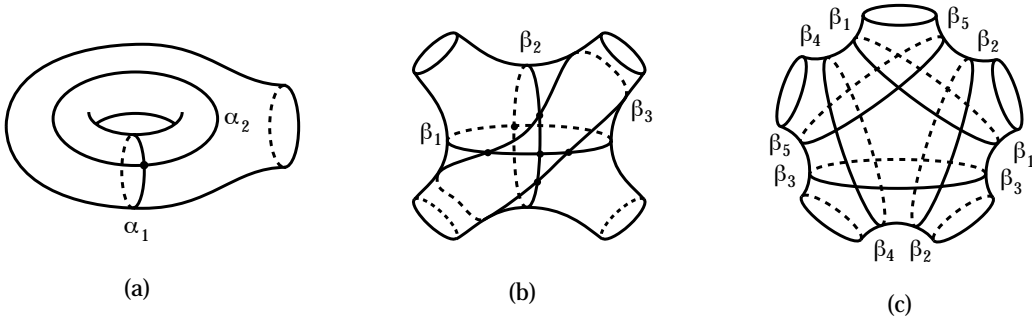

Figure 1

In this definition, $f(a, b)$ denotes the image of f under a homomorphism of \widehat{F}_2 into some profinite group G sending $x \mapsto a$ and $y \mapsto b$. The set \widehat{GT}^1 is made into a group by defining the multiplication law $f \cdot g$ to be given by composition of the automorphisms. In other words, if F_f and F_g denote the automorphisms of \widehat{F}_2 associated to f and $g \in \widehat{GT}^1$, then the automorphism $F_{g \cdot f}$ is defined to be $F_g \circ F_f$, so that we have $g \cdot f = gF_g(f)$.

Remark 1. We note that relation (II) actually takes place in the subgroup of $\widehat{\Gamma}_0^4$ generated by b_1, b_2 and b_3 . This subgroup is described by the three relations: $b_1b_2b_3$ commutes with $b_i, i = 1, 2, 3$. In other words, it is the quotient of the free group generated by b_1, b_2 and b_3 obtained by requiring that $b_1b_2b_3$ be central. Thus, we can write $f(x, y)f(z, x)f(y, z) = 1$ whenever x, y and z generate a group such that xyz is central. Whenever this is the case we also have the useful identity

$$(1) \quad f(x, y)x^{-1}f(z, x)z^{-1}f(y, z)y^{-1} = 1.$$

Although our presentation is unusual, the above group \widehat{GT}^1 easily seen to be equivalent to the set of elements $(\lambda, f) \in \widehat{GT}^1$ with $\lambda = 1$, according to usual definitions. Let Λ be the subset of \widehat{GT}^1 consisting of the elements $f \in \widehat{F}'_2$ satisfying the following additional relation, taking place in $\widehat{\Gamma}_1^2$, where the loops α_i and ϵ_i are as in figure 2.

$$(R) \quad f(e_3, a_1)f(a_2^2, a_3^2)f(e_2, e_3)f(e_1, e_2)f(a_1^2, a_2^2)f(a_3, e_1) = 1.$$

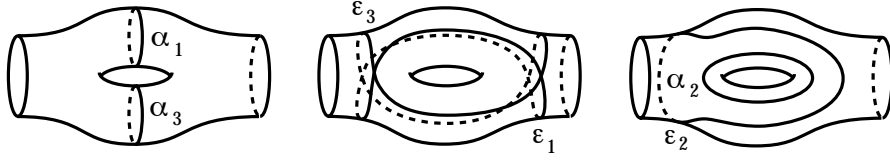

Figure 2

Now we can list our main results.

Theorem A. (Lemma 7 of §3) Λ is a subgroup of \widehat{GT}^1 .

Throughout this paper, the terms “loop” and “curve” refer to homotopy classes of those objects. The intersection (or self-intersection) numbers are defined as the minimal such numbers as the curves vary in their homotopy classes. A simple loop is a loop whose self-intersection number is zero. If α and β are two simple loops on Σ , we write $|\alpha \cap \beta|$ for their intersection number. If two loops intersect in two points but with algebraic intersection equal to 0, then following [G], we write $|\alpha \cap \beta| = 2_0$. Our second main result is the following.

Theorem B. (Theorem 4 of §3) Let Σ be a surface of type (g, n, m) and let \mathcal{P} be a pants decomposition of Σ . Then there exists a group homomorphism $\psi_{\mathcal{P}} : \Lambda \rightarrow \text{Aut}(\widehat{\Gamma}(\Sigma))$ such that setting $F_{\mathcal{P}} = \psi_{\mathcal{P}}(f)$, the automorphism $F_{\mathcal{P}}$ has the following “local properties”:

$$\left\{ \begin{array}{ll} F_{\mathcal{P}}(a) = a & \text{for all } \alpha \in \mathcal{P} \\ F_{\mathcal{P}}(b) = f(a^2, b^2)^{-1} b f(a^2, b^2) & \text{if } |\beta \cap \alpha| = 1 \text{ for some } \alpha \in \mathcal{P} \text{ and } |\beta \cap \alpha'| = 0 \\ & \text{for all } \alpha' \in \mathcal{P}, \alpha' \neq \alpha \\ F_{\mathcal{P}}(c) = f(a, c)^{-1} c f(a, c) & \text{if } |\gamma \cap \alpha| = 2_0 \text{ for some } \alpha \in \mathcal{P} \text{ and } |\gamma \cap \alpha'| = 0 \\ & \text{for all } \alpha' \in \mathcal{P}, \alpha' \neq \alpha. \end{array} \right.$$

Furthermore, the homomorphisms $\Lambda \rightarrow \text{Out}(\widehat{\Gamma}(\Sigma))$ induced by the $\psi_{\mathcal{P}}$ for different \mathcal{P} are all equal and give rise to a canonical homomorphism $\psi_{g,n}^m : \Lambda \rightarrow \text{Out}^*(\widehat{\Gamma}_{g,n}^m)$ for each $g, n, m \geq 0$.

Now we can define the Teichmüller tower studied in this article, and state our third main result.

Definition. We define the *Teichmüller tower of (pure) mapping class groups* to be the collection of pure mapping class groups $\Gamma_{g,n}^m$ for all $g, n, m \geq 0$, equipped with all the natural homomorphisms

$$\Gamma_{g',n'}^{m'} \rightarrow \Gamma_{g,n}^m$$

associated to subsurfaces of type (g', n', m') which can be cut out of $\Sigma_{g,n}^m$ by cutting along disjoint simple closed loops, and defined by sending the Dehn twist along a simple closed

loop in the subsurface to the Dehn twist along the same loop considered in the full surface. We define the *profinite Teichmüller tower* to be the analogous tower with the profinite mapping class groups $\widehat{\Gamma}_{g,n}^m$ and the corresponding homomorphisms.

Definition. For $g, n, m \geq 0$, let $\text{Out}^*(\widehat{\Gamma}_{g,n}^m)$ denote the subgroup of $\text{Out}(\widehat{\Gamma}_{g,n}^m)$ consisting of the outer automorphisms which *preserve conjugacy classes of Dehn twists*; we call these outer automorphisms *special* outer automorphisms of $\widehat{\Gamma}_{g,n}^m$. We use them to define *the group of special outer automorphisms of the tower \mathcal{T}* , as follows. A *special outer automorphism of \mathcal{T}* is a tuple $(\phi_{g,n}^m)_{\{(g,n,m)\}}$ of special outer automorphisms $\phi_{g,n}^m \in \text{Out}^*(\widehat{\Gamma}_{g,n}^m)$ having the following property: for any liftings $\tilde{\phi}_{g,n}^m$ and $\tilde{\phi}_{g',n'}^{m'}$ of $\phi_{g,n}^m$ and $\phi_{g',n'}^{m'}$ to automorphisms of $\widehat{\Gamma}_{g,n}^m$ and $\widehat{\Gamma}_{g',n'}^{m'}$ and any homomorphism $t : \widehat{\Gamma}_{g',n'}^{m'} \rightarrow \widehat{\Gamma}_{g,n}^m$ belonging to \mathcal{T} , the homomorphism $\tilde{\phi}_{g,n}^m \circ t$ differs from $t \circ \tilde{\phi}_{g',n'}^{m'}$ by an inner automorphism of $\widehat{\Gamma}_{g,n}^m$. We denote the group of special outer automorphisms of \mathcal{T} by $\text{Out}^*(\mathcal{T})$. For every (g, n, m) , there is a natural homomorphism

$$(2) \quad \rho_{g,n}^m : \text{Out}^*(\mathcal{T}) \rightarrow \text{Out}^*(\widehat{\Gamma}_{g,n}^m),$$

obtained by sending the tuple $(\phi_{g,n}^m)$ to the (g, n, m) -component $\phi_{g,n}^m$.

Remark 2. We note that the maps $\Gamma(\Sigma') \rightarrow \Gamma(\Sigma)$ are almost injective, that is they are injective except for the possible identification of pairs of boundary components which become identified as a simple loop in Σ . However, the injectivity of these homomorphisms in the profinite case is an important open question.

Theorem C. (Theorem 5 of §3) *There is an injection of groups*

$$\Psi : \Lambda \hookrightarrow \text{Out}^*(\mathcal{T})$$

such that for each $g, n, m \geq 0$, we have $\rho_{g,n}^m \circ \Psi = \psi_{g,n}^m$.

The fundamental tool used in our proofs of all these theorems is a certain complex of curves called the *maximal multicurve complex* $H(\Sigma)$. The definition is long and requires several figures, so we put it in §2. However, the main result on $H(\Sigma)$ which we use in the remainder of the article is the following simple statement.

Theorem D. (Theorem 2 of §2) *The maximal multicurve complex $H(\Sigma)$ is simply connected.*

In §3, we make fundamental use of the fact that an explicit presentation of the mapping class groups $\Gamma_{g,n}^m$ is known, the generators being the Dehn twists along simple closed curves on the topological surface $\Sigma_{g,n}^m$. Let us conclude this introduction with this presentation, a first version of which was given by Gervais [G], and a subsequent improvement by Feng

Luo in [FL]. Note that we compose Dehn twists from right to left so that ab means the twist b followed by the twist a .

We define the following *braid relations*:

$$(C) \quad ab = ba \quad \text{if} \quad |\alpha \cap \beta| = 0$$

$$(B) \quad c = bab^{-1} \quad \text{if} \quad |\alpha \cap \beta| = 1 \quad \text{and} \quad \gamma = b(\alpha)$$

Relation B implies the well-known braid relation $aba = bab$ for $|\alpha \cap \beta| = 1$ (cf. [FL] Lemma 1).

The *doughnut relation*, taking place on a subsurface Σ' of Σ of type $(1, i, j)$ with $i + j = 1$, is given by

$$(D) \quad (a_1 a_2 a_1)^4 = d$$

where δ is the boundary loop of Σ' (so it may just surround a puncture), and α_1 and α_2 are as in figure 1(a).

Finally, the *lantern relation*, taking place on a subsurface Σ' of Σ of type $(0, i, j)$ with $i + j = 4$, is given by

$$(L) \quad a_1 a_2 a_3 a_4 = b_1 b_2 b_3$$

where the α_i are loops on Σ bounding Σ' (we allow α_i to be a loop surrounding a puncture, so that $a_i = 1$) and β_1, β_2 and β_3 are the loops in the interior of Σ' shown in figure 1(b). These loops intersect each other in $|2_0|$.

Theorem 1. ([G] Thm. A, [FL]) *A presentation for the pure mapping class group $\Gamma_{g,n}^m$ for every $g, n, m \geq 0$ is given by taking all Dehn twists along simple closed loops as generators and imposing all the relations (C), (B), (D) and (L).*

§2. Transformations of pants decompositions.

In this section we shall be concerned with curves on the surface Σ , and for this purpose the distinction between punctures and boundary components becomes irrelevant, so for simplicity we shall assume there are no punctures, only boundary components. Thus we say Σ has type (g, n) if it has genus g and n boundary components.

By a *maximal multicurve* on Σ we mean a finite collection \mathcal{P} of disjoint simple loops (modulo isotopy) cutting Σ into pieces which are surfaces of type $(0, 3)$. In other words, \mathcal{P} defines a *pants decomposition* of Σ . The number of curves in a maximal multicurve is $3g - 3 + n$, and the number of complementary components is $2g - 2 + n = |\chi(\Sigma)|$.

We are interested in two fundamental types of transformations of pants decompositions of Σ . Let \mathcal{P} be a pants decomposition, and suppose that one of the loops β of \mathcal{P} is such that deleting β from \mathcal{P} produces a complementary component of type $(1, 1)$. This is equivalent to saying there is a simple loop γ intersecting β in one point transversely and disjoint from all the other loops in \mathcal{P} . In this case, replacing β by γ in \mathcal{P} produces a new pants decomposition \mathcal{P}' . We call this replacement a *simple move*, or S-move, and write $\mathcal{P}' = S_{\beta, \gamma}(\mathcal{P})$.

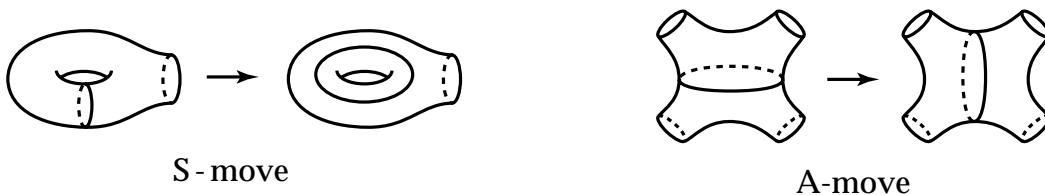

Figure 3

In similar fashion, if \mathcal{P} contains a loop β such that deleting β from \mathcal{P} produces a complementary component of type $(0, 4)$, then we obtain a new pants decomposition \mathcal{P}' by replacing β by a loop γ such that $|\gamma \cap \beta| = 2$, and disjoint from the other curves of \mathcal{P} . The transformation $\mathcal{P} \rightarrow \mathcal{P}'$ in this case is called an *associativity move* or A-move, and we write $\mathcal{P}' = A_{\beta, \gamma}(\mathcal{P})$. (In the surface of type $(0, 4)$ containing β and γ these two curves separate the four boundary circles in two different ways, and one can view these separation patterns as analogous to inserting parentheses via associativity.) Note that the inverse of an S-move is again an S-move, and the inverse of an A-move is again an A-move.

Remark 3. It is known that compositions of S-moves and A-moves act transitively on the set of isotopy classes of pants decompositions of Σ . In other words, if we build a graph by letting its vertices be isotopy classes of pants decompositions of Σ , with an edge joining two vertices whenever they are related by an S-move or A-move, then this graph is connected. This statement was given in the final sentence of [HT], and we fill in the details of this argument in the proof of Theorem 2 below.

Definition. The *maximal multicurve complex* $H(\Sigma)$ is the two-dimensional cell complex having vertices the isotopy classes of maximal multicurves in Σ , with an edge joining two vertices whenever the corresponding maximal multicurves differ by a single S-move or A-move, and with faces added to fill in all cycles of the following five forms:

- (3A) Suppose that deleting one loop from a pants decomposition creates a complementary component of type $(0, 4)$. Then in this component there are loops β_1 , β_2 , and β_3 , shown in figure 4(a), which yield a cycle of three A-moves: $\beta_1 \rightarrow \beta_2 \rightarrow \beta_3 \rightarrow \beta_1$. (No other loops in the given pants decomposition change.)

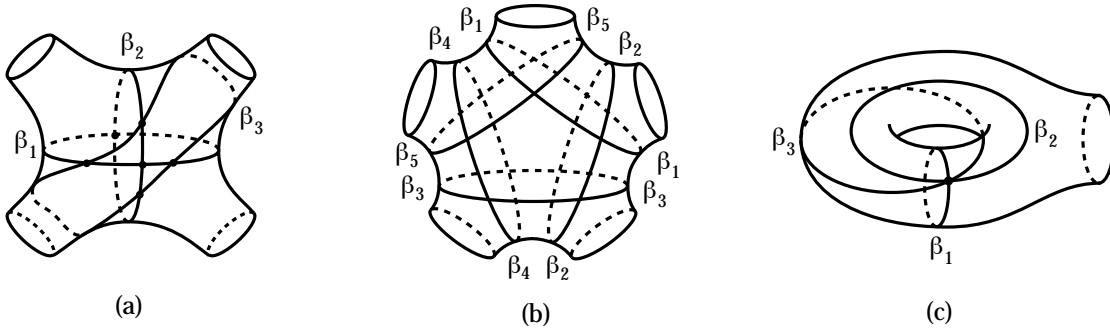

Figure 4

- (5A) Suppose that deleting two loops from a pants decomposition creates a complementary component of type $(0, 5)$. Then in this component there is a cycle of five A-moves involving the loops β_i shown in figure 4(b): $\{\beta_1, \beta_3\} \rightarrow \{\beta_1, \beta_4\} \rightarrow \{\beta_2, \beta_4\} \rightarrow \{\beta_2, \beta_5\} \rightarrow \{\beta_3, \beta_5\} \rightarrow \{\beta_3, \beta_1\}$.
- (3S) Suppose that deleting one loop from a pants decomposition creates a complementary component of type $(1, 1)$. Then in this component there are loops β_1 , β_2 , and β_2 , shown in figure 4(c), which yield a cycle of three S-moves: $\beta_1 \rightarrow \beta_2 \rightarrow \beta_3 \rightarrow \beta_1$.
- (6AS) Suppose that deleting two loops from a pants decomposition creates a complementary component of type $(1, 2)$. Then in this component there is a cycle of four A-moves and two S-moves shown in figure 5: $\{\alpha_1, \alpha_3\} \rightarrow \{\alpha_1, \varepsilon_3\} \rightarrow \{\alpha_2, \varepsilon_3\} \rightarrow \{\alpha_2, \varepsilon_3\} \rightarrow \{\alpha_2, \varepsilon_2\} \rightarrow \{\alpha_2, \varepsilon_1\} \rightarrow \{\alpha_3, \varepsilon_1\} \rightarrow \{\alpha_3, \alpha_1\}$.

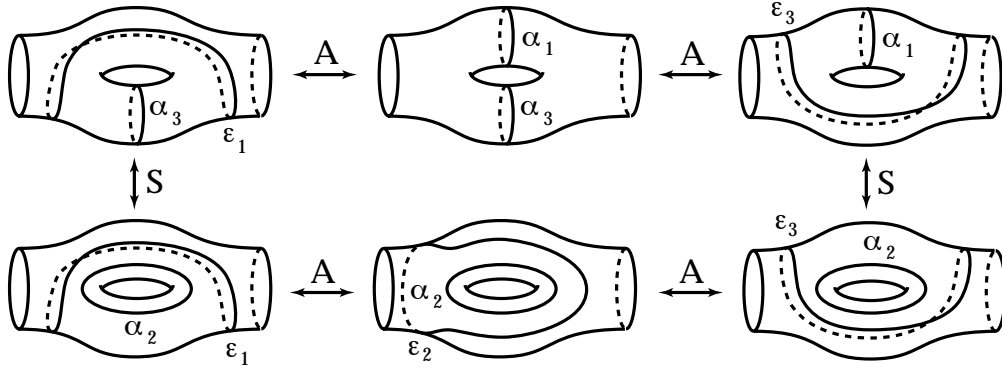

Figure 5

(C) If two moves which are either A-moves or S-moves are supported in disjoint subsurfaces of Σ , then they commute, and their commutator is a cycle of four moves. We call them *disjoint moves*.

Remark 4. The four basic relations 3A, 3S, 5A and 6AS live on surfaces of type $\Sigma_{0,4}$, $\Sigma_{1,1}$, $\Sigma_{0,5}$ and $\Sigma_{1,2}$ respectively. This fact is closely related to Grothendieck's philosophy of the importance of the first two levels of the Teichmüller tower, a level being defined by its modular dimension $3g - 3 + n$.

The remainder of this section is devoted to the proof of the following theorem.

Theorem 2. *The maximal multicurve complex $H(\Sigma)$ is simply connected.*

Remark 5. Thus any two sequences of A-moves and S-moves joining two given pants decompositions can be obtained one from the other by a finite number of insertions or deletions of the five types of cycles, together with the trivial operation of inserting or deleting a move followed by its inverse. For example, if Σ has type (0,4) or (1,1), the two cases when a maximum multicurve contains just one circle, then $H(\Sigma)$ is the two-dimensional complex shown in figure 6, consisting entirely of triangles since only the relations 3A or 3S are possible in these two cases. The vertices of $H(\Sigma)$ are labelled by slopes, which classify the nontrivial isotopy classes of circles on Σ . This is a familiar fact for the torus, where slopes are defined via homology. For the (0,4) surface, slopes are defined by lifting curves to the torus via the standard two-sheeted branched covering of the sphere by the torus, branched over four points which become the four boundary circles of the (0,4) surface.

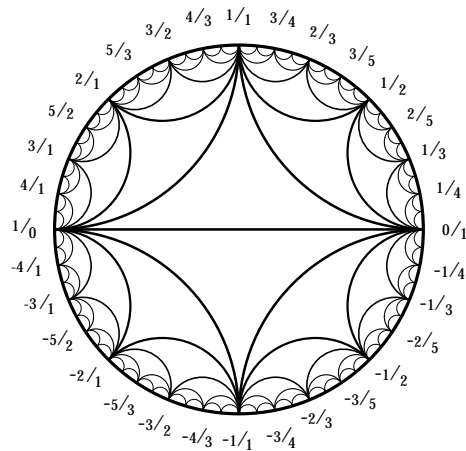

Figure 6

PROOF OF THEOREM 2. This uses the same basic approach as in [HT], which consists of realizing multicurves as level sets of Morse functions $f: \Sigma \rightarrow \mathbb{R}$.

Let $I = [0, 1]$. We consider Morse functions $f: (\Sigma, \partial\Sigma) \rightarrow (I, 0)$ whose critical points all lie in the interior of Σ . To such a Morse function we associate a finite graph $\Gamma(f)$, which is the quotient space of Σ obtained by collapsing all points in the same component of a level set $f^{-1}(a)$ to a single point in $\Gamma(f)$. If we assume f is generic, so that all critical points have distinct critical values, then the vertices of $\Gamma(f)$ all have valence 1 or 3 and arise from critical points of f or from boundary components of Σ . Namely, boundary components give rise to vertices of valence 1, as do local maxima and minima of f , while saddles of f produce vertices of valence 3. See figure 2 of [HT] for pictures. We can associate to such a function f a maximal multicurve $C(f)$, unique up to isotopy, by either of the following two equivalent procedures:

- (1) Choose one point in the interior of each edge of $\Gamma(f)$, take the loops in Σ which these points correspond to, then delete those loops which bound disks in Σ or are isotopic to boundary components, and replace collections of mutually isotopic loops by a single loop.
- (2) Let $\Gamma_0(f)$ be the unique smallest subgraph of $\Gamma(f)$ which $\Gamma(f)$ deformation retracts to and which contains all the vertices corresponding to boundary components of Σ . If $\Gamma_0(f)$ has vertices of valence 2, regard these not as vertices but as interior points of edges. In each edge of $\Gamma_0(f)$ not having a valence 1 vertex as an endpoint, choose an interior point distinct from the points which were vertices of valence 2. Then let $C(f)$ consist of the loops in Σ corresponding to these chosen points of $\Gamma_0(f)$.

Every maximal multicurve arises as $C(f)$ for some generic $f: (\Sigma, \partial\Sigma) \rightarrow (I, 0)$. To obtain such an f , one can first define it near the loops of the given multicurve and the loops of $\partial\Sigma$ so that all these loops are noncritical level curves, then extend to a function

defined on all of Σ , then perturb this function to be a generic Morse function.

After these preliminaries, we can now show that $H(\Sigma)$ is connected. Given two maximal multicurves, realize them as $C(f_0)$ and $C(f_1)$. Connect the generic Morse functions f_0 and f_1 by a one-parameter family $f_t: (\Sigma, \partial\Sigma) \rightarrow (I, 0)$ with no critical points near $\partial\Sigma$. This is possible since the space of such functions is convex. After perturbing the family f_t to be generic, then f_t is a generic Morse function for each t , except for two phenomena: birth-death critical points, and *crossings* interchanging the heights of two consecutive nondegenerate critical points, as described on p.224 of [HT]. The associated maximal multicurves $C(f_t)$ will be independent of t except for possible changes caused by these two phenomena. Birth-death points are local in nature and occur in the interior of an annulus in Σ bounded by two level curves, hence produce no change in $C(f_t)$. Crossings can affect $C(f_t)$ only when both critical points are saddles. Up to level-preserving diffeomorphism, there are five possible configurations for such a pair of saddles, shown in figures 5 and 6 of [HT]. The three simplest configurations are shown in figure 7 below, and one can see that the intermediate level curve dividing the subsurface into two pairs of pants changes by an A-move as the relative heights of the two saddles are switched.

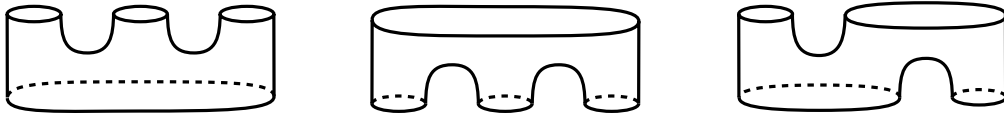

Figure 7

The fourth configuration, shown in the left half of figure 8 below, also occurs in a subsurface of type (0,4). Here the crossing produces an interchange of the level curves α_1 and α_2 . These two curves intersect in four points, and can be redrawn as in the right half of the figure. They are related by a pair of A-moves, interpolating between them the horizontal loop β . (In terms of figure 6, we can connect the slope 1 and -1 vertices by an edgepath passing through either the slope 0 or slope ∞ vertices.)

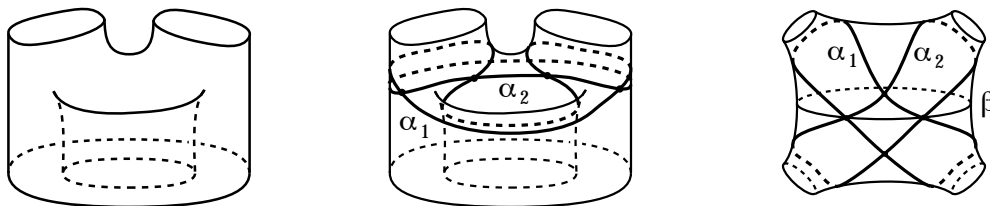

Figure 8

The fifth configuration takes place in a subsurface of type (1,2), as shown in figure 9. Here the two level curves in the left-hand figure change to the two in the right-hand figure.

This is precisely the change from the pair of loops in the middle of the upper row of figure 5 to the pair in the middle of the lower row. Thus the change is realized by an A-move, an S-move, and an A-move. This finishes the proof that $H(\Sigma)$ is connected.

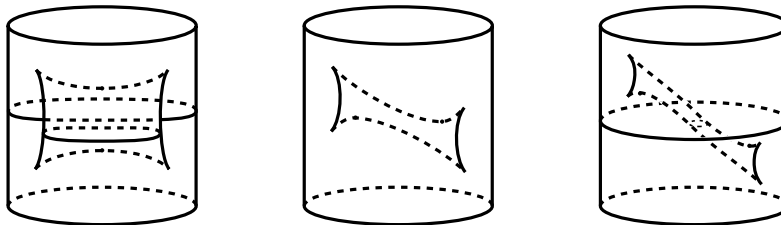

Figure 9

Note that the edgepath in $H(\Sigma)$ associated to the generic family f_t is not quite unique. For a crossing as in the fourth configuration, shown in figure 8, there were two associated edgepaths in $H(\Sigma)$, which in figure 6 corresponded to passing from slope 1 to slope -1 through either slope 0 or slope ∞ . These two edgepaths are homotopic in $H(\Sigma)$ using two relations of type 3A. Similarly, a crossing in the fifth configuration, in figure 9, corresponded to an edgepath of three edges, but there are precisely two choices for this edgepath, the two ways of going halfway around figure 5, so these two choices are related by a relation of type 6AS. Thus we conclude that the edgepath associated to a generic family f_t is unique up to homotopy in $H(\Sigma)$.

A preliminary step to showing $H(\Sigma)$ is simply connected is:

Lemma 3. *Every edgepath in $H(\Sigma)$ is homotopic in the 1-skeleton of $H(\Sigma)$ to an edgepath which is the sequence of maximal multicurves $C(f_t)$ associated to a generic one-parameter family f_t .*

PROOF. First we show:

- (*) If the multicurves $C(f_0)$ and $C(f_1)$ are isotopic, then there is a generic family f_t joining f_0 and f_1 such that f_t has nonsingular level curves in the isotopy classes of all the loops of $C(f_0) = C(f_1)$ for all t .

This can be shown as follows. Composing f_0 with an ambient isotopy of Σ taking the curves in $C(f_0)$ to the curves in $C(f_1)$, we may assume that $C(f_0) = C(f_1)$. The normal directions to these curves defined by increasing values of f_0 and f_1 may not agree, but this can easily be achieved by a deformation of f_0 near $C(f_0)$. Then we can further deform f_0 so that it agrees with f_1 near $C(f_0) = C(f_1)$ and near $\partial\Sigma$, without changing the local behavior near critical points. Then, keeping the new f_0 fixed where we have made it agree with f_1 , we can deform it to coincide with f_1 everywhere by a generic family f_t . To deduce lemma 3 from (*) it then suffices to realize an arbitrary A-move or S-move. For A-moves

we can just use figure 7. Similarly, figure 9 realizes a given S-move sandwiched between two A-moves, but we can realize the inverses of these A-moves, so the result follows. \diamond

Now consider an arbitrary loop in $H(\Sigma)$. By lemma 3, together with the statement (*) in its proof, this loop is homotopic to a loop of the form $C(f_t)$ for a loop of generic functions f_t . Since the space of functions is convex, there is a 2-parameter family f_{tu} giving a nullhomotopy of the loop f_t . We may assume f_{tu} is a generic 2-parameter family, so that f_{tu_0} is a generic 1-parameter family for each u_0 except for the six types of isolated phenomena listed on page 230 of [HT]. The proof that $H(\Sigma)$ is simply connected will be achieved by showing that these phenomena change the associated loop $C(f_{tu_0})$ by homotopy in $H(\Sigma)$.

The first three of the six involve degenerate critical points and are uninteresting for our purposes. In each case the change in generic 1-parameter family is supported in subsurfaces of Σ of type $(0, k)$, $k \leq 3$, bounded by level curves, so there is no change in the associated path in $H(\Sigma)$.

The last three phenomena, numbered (4), (5), and (6) on page 230 of [HT], involve only nondegenerate critical points, which we may assume are saddles since otherwise the reasoning in the preceding paragraph shows that nothing interesting is happening. Number (4) is rather trivial: A crossing and its “inverse” are cancelled or introduced. We may choose the segment of the edgepath in $H(\Sigma)$ associated to the crossing and its inverse so that it simply backtracks across up to three edges, hence the edgepath changes only by homotopy. Number (5) is the commutation of two crossings involving four distinct saddles. This corresponds to a homotopy of the associated edgepath across 2-cells representing the commutation relation C. Number (6) arises when three saddles have the same f_{tu} -value at an isolated point in the (t, u) -parameter space. As one circles around this value, the heights of the saddles vary through the six possible orders: 123, 132, 312, 321, 231, 213, 123. To finish the proof it remains to analyze the various possible configurations for these three saddles. The interesting cases not covered by previous arguments are when the three saddles lie in a connected subsurface bounded by level curves just above and below the three saddles. Note that we can immediately say that all relations among moves, apart from the commutation relation, are supported in subsurfaces of types $(0,5)$ and $(1,3)$. This is because a subsurface bounded by level curves with three saddles, hence Euler characteristic -3 , must have at least two boundary circles, one below the saddles and one above, so if the surface is connected it must have type $(0,5)$ or $(1,3)$. The analysis below will show that the $(1,3)$ subsurfaces can be reduced to $(1,2)$ subsurfaces. There are sixteen possible configurations of three saddles on one level, shown in figure 10, where the saddles are regarded as 1-handles, or rectangles, attached to level curves. The sixteen configurations are grouped into eight pairs, the two configurations in each pair being related by replacing f_{tu} by its negative.

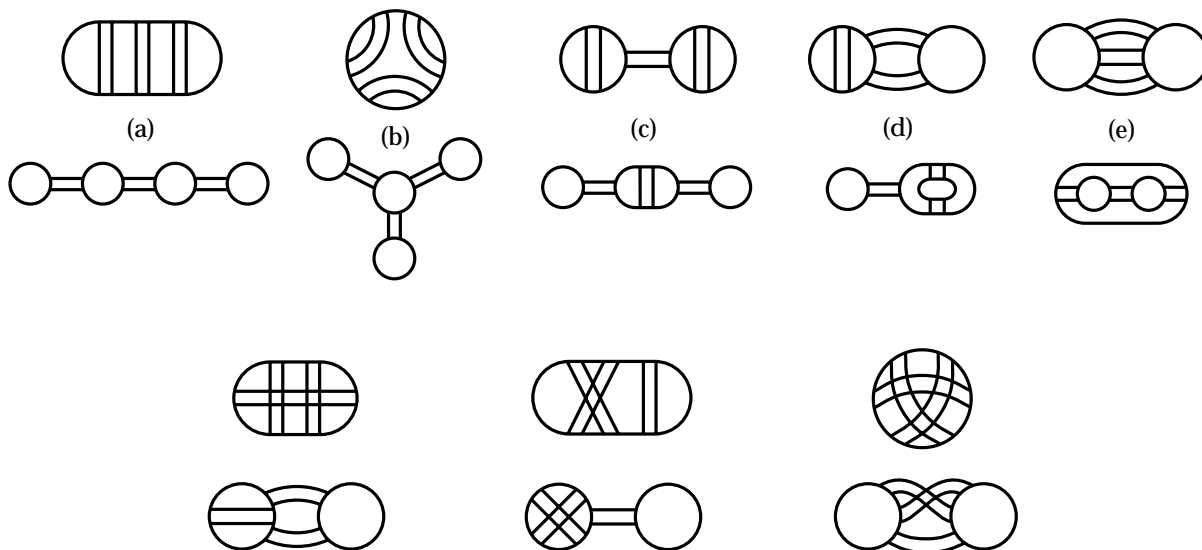

Figure 10

The first five pairs involve a genus zero subsurface and are somewhat easier to analyze visually than the other three pairs, which occur in a genus one subsurface. We consider each of these five pairs in turn.

(a) A picture of the subsurface with $\pm f_{tu}$ as the height function is shown in figure 11.

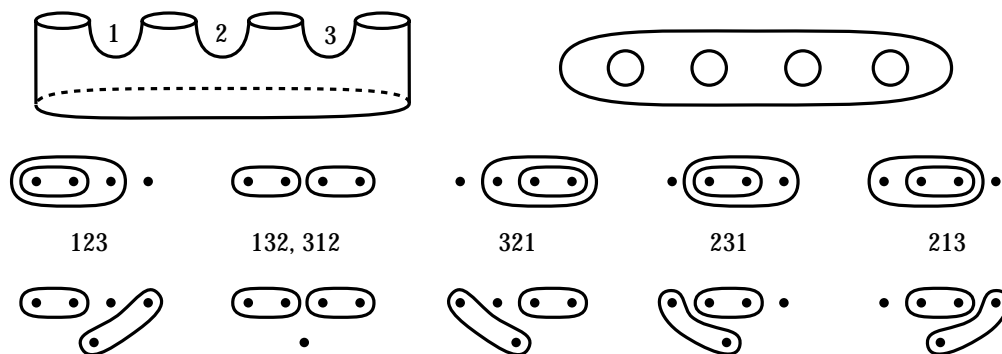

Figure 11

Viewed from above, the surface can be seen as a disk with four subdisks deleted, a $(0,5)$ surface. In the second row of the figure we show the various configurations of level curves when the saddles are perturbed to each of the six possible orders. For example, the first diagram shows the order 123, where the saddle 1 is the highest, 2 is the middle, and 3 is the lowest. The two circles shown lie between the two adjacent pairs of saddles. The four dots represent four of the five boundary circles of the $(0,5)$ surface, the fifth being regarded as the point at infinity in the one-point compactification of the plane. In the third row of

the figure this fifth point is brought in to a finite point and the level circles are redrawn accordingly. The two adjacent orderings 132 and 312 produce the same level curves, so we have in reality a cycle of five maximal multicurves. Each is related to the next (and the first to the last) by an A-move, and the whole cycle is the relation 5A.

(c) We treat this case next since it is very similar to (a). From figure 12 it is clear that one again has the relation 5A.

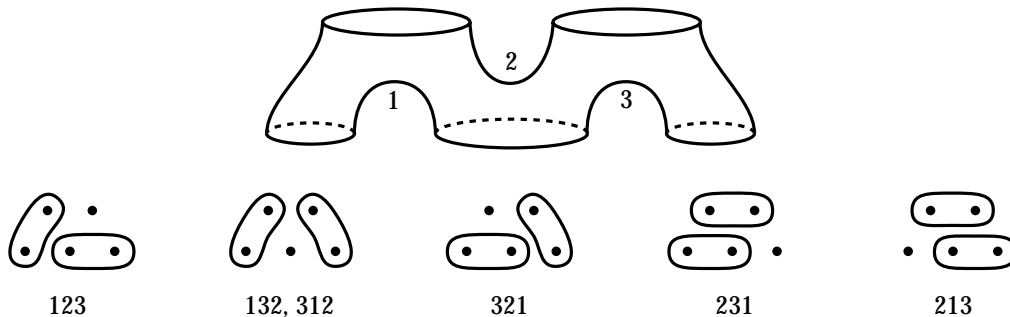

Figure 12

(b) Here the 3-fold rotational symmetry makes it unlikely that one would directly get the relation 5A. The second row of figure 13 shows the cycle of six multicurves.

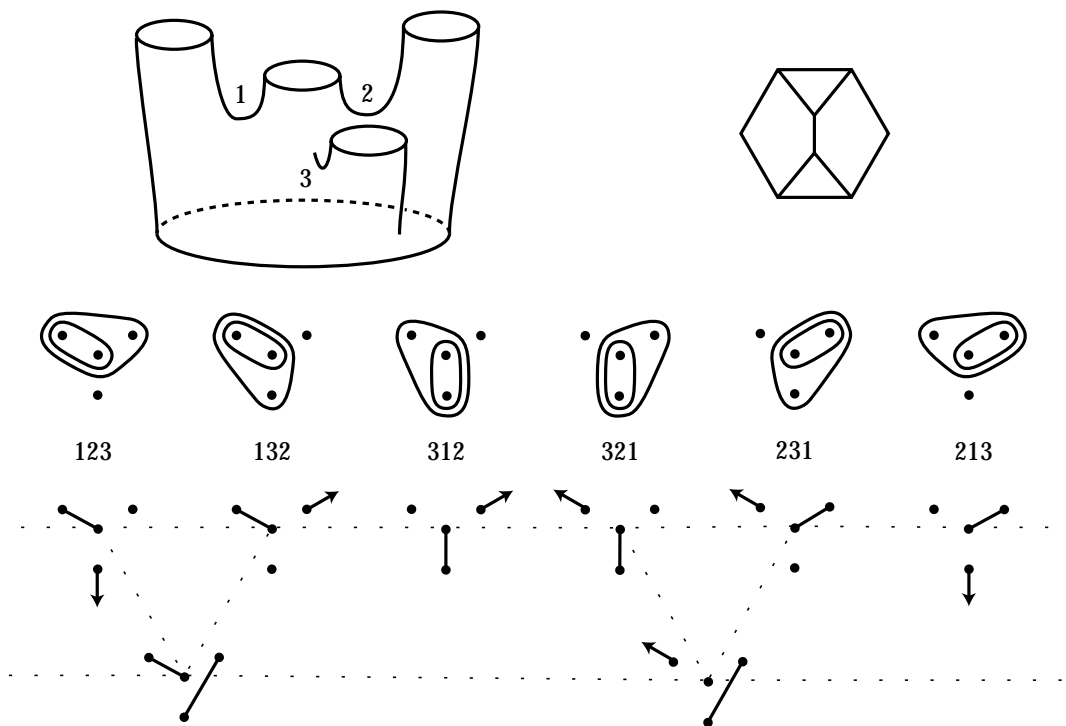

Figure 13

It is convenient to simplify the notation at this point by representing the two circles in a pants decomposition of the $(0,5)$ surface by two arcs joining four of the five points representing the boundary circles. The boundary of a neighborhood of each arc is then a circle separating two of the five points from the other three. The third row of the figure shows the cycle of six multicurves in this notation, with the fifth point at infinity and an arc to this point indicated by an arrow from one of the other four points. Note that we have a cycle of six A-moves. This can be reduced to two 3A and two 5A relations by adjoining the two configurations in the fourth row. Schematically, one subdivides a hexagon into two pentagons and two triangles by inserting two interior vertices, as shown.

(d) Here the cycle of six multicurves contains two steps which are not A-moves but resolve into a pair of A-moves. Thus we have a cycle of eight A-moves, and this decomposes into two 5A relations, as shown in figure 14.

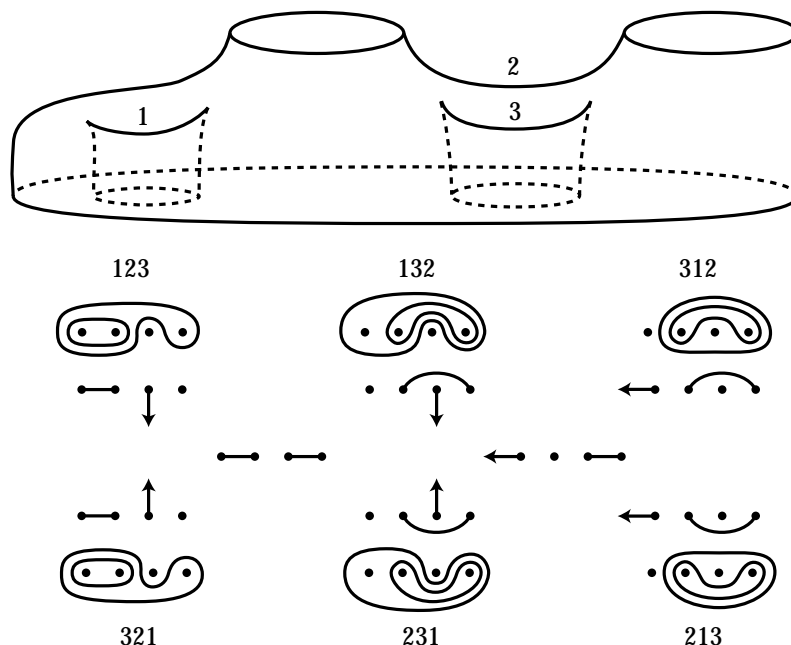

Figure 14

(e) In this case we have the configuration shown in figure 15, with 3-fold symmetry. The cycle of six multicurves has three steps which resolve into pairs of A-moves, so we have a cycle of nine A-moves. This can be reduced to three 3A relations and four cycles of six A-moves. After a permutation of the five boundary circles of the $(0,5)$ surface, each of these 6-cycles becomes the 6-cycle considered in case (b).

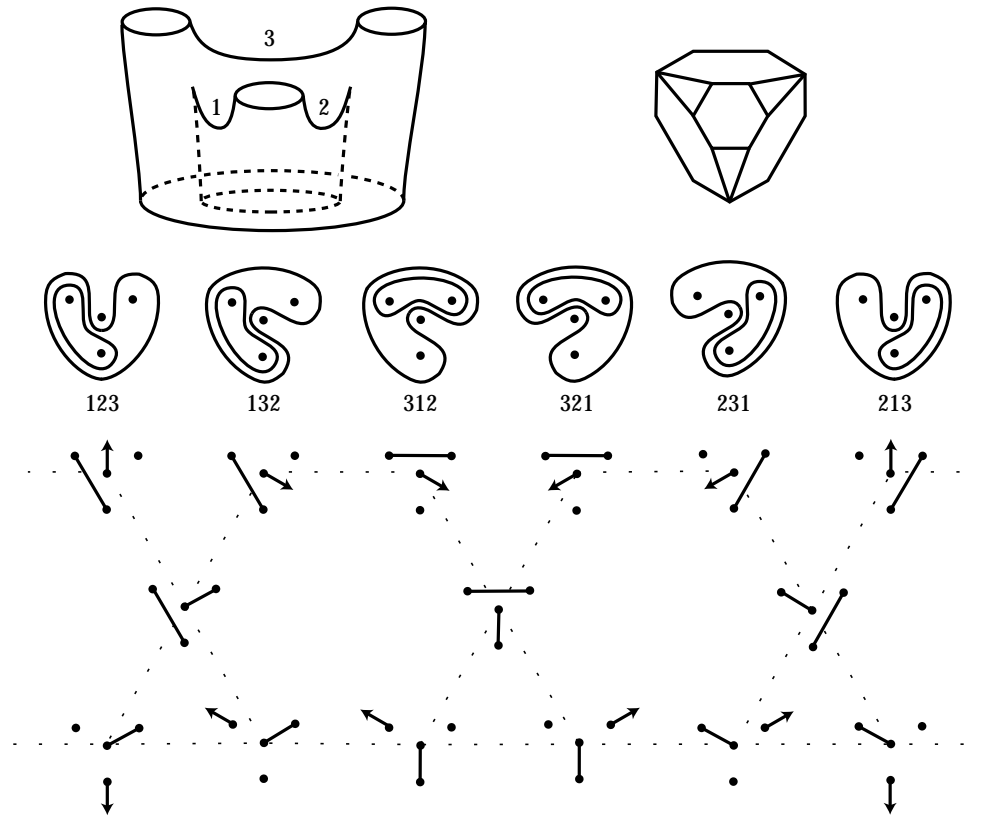

Figure 15

This completes the analysis of the five cases of the phenomenon (5) involving genus 0 surfaces. In particular, the theorem is now proved for surfaces of type $(0, n)$. To finish the proof it would suffice to do a similar analysis of the three remaining configurations of three saddles in surfaces of type $(1, 3)$. However, the cycles of A- and S-moves arising from these configurations are somewhat more complicated than those in the genus zero configurations, so instead of carrying out this analysis, we shall make a more general argument, showing that the relation 3A and 6AS suffice to reduce the genus one case to the genus zero case. So let Σ have type $(1, n)$. We can view the boundary components of Σ as punctures rather than circles, so Σ is the complement of n points in a torus $\widehat{\Sigma}$. Given an edgepath loop γ in $H(\Sigma)$, its image $\hat{\gamma}$ in $H(\widehat{\Sigma})$ is nullhomotopic since the explicit picture of $H(\widehat{\Sigma})$ shows it is contractible. Our task is to show the nullhomotopy of $\hat{\gamma}$ lifts to a nullhomotopy of γ .

The nullhomotopy of $\hat{\gamma}$ gives a map $\hat{g}: D^2 \rightarrow H(\widehat{\Sigma})$. Making \hat{g} transverse to the graph dual to the 1-skeleton of $H(\widehat{\Sigma})$, the preimage of this dual graph is a graph G in D^2 , intersecting the boundary of D^2 transversely, as depicted by the solid lines in the left half of figure 16.

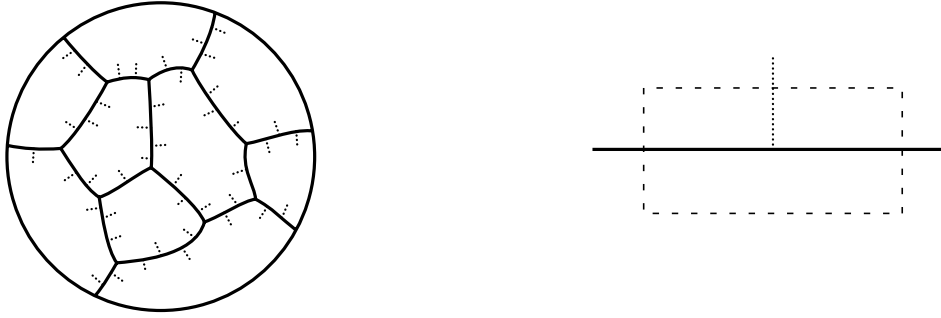

Figure 16

The vertices of G in the interior of D^2 have valence three, and are the preimages of the center points of triangles of $H(\widehat{\Sigma})$. Each such vertex corresponds to three simple loops on $\widehat{\Sigma}$ having distinct slopes and disjoint except for a single point where they all three intersect transversely. Each edge of G corresponds to a pair of simple loops on $\widehat{\Sigma}$ of distinct slopes, intersecting transversely in one point. The complementary regions of G correspond to single loops.

In a neighborhood N of G we can choose all these loops in $\widehat{\Sigma}$ to vary continuously with the point in N . We can also assume these continuously varying loops have general position intersections with the n puncture points, so that they are disjoint from the punctures except along arcs, shown dotted in figure 16, abutting interior points of edges of G , where a single loop slides across a puncture. Near such a dotted arc we thus have three loops: the loop before it slides across the puncture, the loop after it slides across the puncture, and a third loop intersecting each of the two loops in one point transversely. We can perturb the first two loops to be disjoint, so they are essentially two parallel copies of the same loop with the puncture between them. A neighborhood of the three loops is then a surface of type (1,2). We can identify the three loops in this subsurface with the three simplest loops in figure 5: the upper and lower meridian loops and the longitudinal loop. The puncture is one of the two boundary circles of the subsurface. Adjoining the other loops shown in the figure, we get various pants decompositions of the subsurface. Choosing a fixed pants decomposition of the rest of Σ then gives a way of lifting \hat{g} to $g: D^2 \rightarrow H(\Sigma)$ in a neighborhood of the dotted arc, by superimposing figure 5 on the right half of figure 16. Since the chosen loops are disjoint from punctures elsewhere along G , we can then extend the lift g over G by extending the given loops to pants decompositions of Σ , using just the fact that any two pants decompositions of a genus zero surface can be connected by a sequence of A-moves. Finally, the lift g can be extended over the complementary regions of G since the theorem is already proved for genus zero surfaces. \diamond

§3. The Λ -action on the Teichmüller tower.

In this section, we return to the definitions of Λ , \mathcal{T} and $\text{Out}^*(\mathcal{T})$ given in §1. In both this and the next section, curves and diffeomorphisms are understood up to isotopy, and for the sake of brevity this will not be explicitly mentioned every time. Naturally this convention applies also to the objects built out of these two classes, as for instance pants decompositions. The main results of this section are stated in theorems 4 and 5.

Theorem 4. *Let Σ be a surface of type (g, n, m) and let \mathcal{P} be a pants decomposition of Σ . Then there exists a group homomorphism $\psi_{\mathcal{P}} : \Lambda \rightarrow \text{Aut}(\widehat{\Gamma}(\Sigma))$ such that setting $F_{\mathcal{P}} = \psi_{\mathcal{P}}(f)$, the automorphism $F_{\mathcal{P}}$ has the following “local properties”:*

$$\left\{ \begin{array}{ll} F_{\mathcal{P}}(a) = a & \text{for all } \alpha \in \mathcal{P} \\ F_{\mathcal{P}}(b) = f(a^2, b^2)^{-1} b f(a^2, b^2) & \text{if } |\beta \cap \alpha| = 1 \text{ for some } \alpha \in \mathcal{P} \text{ and } |\beta \cap \alpha'| = 0 \\ & \text{for all } \alpha' \in \mathcal{P}, \alpha' \neq \alpha \\ F_{\mathcal{P}}(c) = f(a, c)^{-1} c f(a, c) & \text{if } |\gamma \cap \alpha| = 2_0 \text{ for some } \alpha \in \mathcal{P} \text{ and } |\gamma \cap \alpha'| = 0 \\ & \text{for all } \alpha' \in \mathcal{P}, \alpha' \neq \alpha. \end{array} \right.$$

Furthermore, the homomorphisms $\Lambda \rightarrow \text{Out}(\widehat{\Gamma}(\Sigma))$ induced by the $\psi_{\mathcal{P}}$ for different \mathcal{P} are all equal and give rise to a canonical homomorphism $\psi_{g,n}^m : \Lambda \rightarrow \text{Out}^*(\widehat{\Gamma}_{g,n}^m)$ for each $g, n, m \geq 0$.

Remark 6. The conditions defining when the second (resp. third) local property can take place can be rephrased as follows: the pants decomposition \mathcal{P}' obtained from \mathcal{P} by replacing the loop α by β (resp. by γ) is obtained from \mathcal{P} by a single S-move (resp. a single A-move).

Theorem 5. *There is an injection of groups*

$$\Psi : \Lambda \hookrightarrow \text{Out}^*(\mathcal{T})$$

such that for each $g, n, m \geq 0$, we have $\rho_{g,n}^m \circ \Psi = \psi_{g,n}^m$.

PROOF OF THEOREM 4. The proof has three steps. Steps 1 and 2 are devoted to constructing an automorphism $F_{\mathcal{P}}$ of $\widehat{\Gamma}(\Sigma)$ associated to each $f \in \Lambda$ and each pants decomposition \mathcal{P} . In Step 1, we define the value of $F_{\mathcal{P}}$ on the Dehn twists generating $\widehat{\Gamma}(\Sigma)$. In order to give the value of $F_{\mathcal{P}}$ on an infinite number of generators, we give a procedure for computing this value and then show that the defining relations (I), (II), (III) and (R) of Λ ensure that this procedure is well-defined. In Step 2, we show that the action of $F_{\mathcal{P}}$ on the generators of $\widehat{\Gamma}(\Sigma)$ respects all the defining relations of $\widehat{\Gamma}(\Sigma) \simeq \widehat{\Gamma}_{g,n}^m$ given in theorem 1, so that $F_{\mathcal{P}}$ gives an automorphism of $\widehat{\Gamma}(\Sigma)$. Finally, in Step 3 we show that Λ is a group and that the map $\psi_{\mathcal{P}} : \Lambda \rightarrow \text{Aut}(\widehat{\Gamma}(\Sigma))$ is in fact a group homomorphism, and that all the $\psi_{\mathcal{P}}$ induce the same homomorphism $\Lambda \rightarrow \text{Out}^*(\widehat{\Gamma}_{g,n}^m)$.

Step 1. The generators of $\widehat{\Gamma}(\Sigma)$. Fix a pants decomposition \mathcal{P} of Σ , and let us define the automorphism $F_{\mathcal{P}}$ of $\widehat{\Gamma}(\Sigma)$. To start with, we define the values of $F_{\mathcal{P}}$ on the Dehn twists of $\widehat{\Gamma}(\Sigma)$ via the following procedure.

To begin with, set $F_{\mathcal{P}}(a) = a$ for all the loops $\alpha \in \mathcal{P}$, and also for all boundary twists, i.e. for all α corresponding to boundary components of Σ . Now let us define $F_{\mathcal{P}}(b)$ for any simple loop β on Σ . By remark 3, there exists a pants decomposition \mathcal{Q} of Σ containing β and a finite sequence $\mathcal{S} = \mathcal{S}_{\beta_r, \gamma_r} \circ \cdots \circ \mathcal{S}_{\beta_1, \gamma_1}$ of S- and A-moves taking \mathcal{P} to \mathcal{Q} . We define

$$(3) \quad \begin{aligned} F_{\mathcal{P}}(b) &= \text{inn} \left(\prod_{i=r}^1 f(b_i^{\epsilon_i}, c_i^{\epsilon_i}) \right) (b) \\ &= f(b_1^{\epsilon_1}, c_1^{\epsilon_1})^{-1} \cdots f(b_r^{\epsilon_r}, c_r^{\epsilon_r})^{-1} b f(b_r^{\epsilon_r}, c_r^{\epsilon_r}) \cdots f(b_1^{\epsilon_1}, c_1^{\epsilon_1}), \end{aligned}$$

where

$$\epsilon_i = \begin{cases} 1 & \text{if } \mathcal{S}_{\beta_i, \gamma_i} \text{ is an A-move} \\ 2 & \text{if } \mathcal{S}_{\beta_i, \gamma_i} \text{ is an S-move.} \end{cases}$$

Lemma 6. *The value $F_{\mathcal{P}}(b) \in \widehat{\Gamma}(\Sigma)$ is independent of the choice of the sequence \mathcal{S} and of the pants decomposition \mathcal{Q} containing β .*

PROOF. Let \mathcal{Q} be a pants decomposition containing β , and consider two sequences \mathcal{S} and \mathcal{S}' taking \mathcal{P} to \mathcal{Q} . By theorem 2, \mathcal{S} can be homotoped to \mathcal{S}' in $H(\Sigma)$ via substitutions from the basic cycles (3A), (5A), (3S) and (6AS), and from the commutation relations (C). So we only have to check that the action defined by (3) respects the relations $\mathcal{S}_{3A} = 1$, $\mathcal{S}_{5A} = 1$, $\mathcal{S}_{3S} = 1$, $\mathcal{S}_{6AS} = 1$ and $\mathcal{S}_C = 1$. Relations (3A) and (5A) are respected because of relations (II) and (III) in the definition of \widehat{GT}^1 ; that is, a sequence of type \mathcal{S}_{3A} (resp. \mathcal{S}_{5A}) induces a conjugation by an element which is unity by relation (II) (resp. (III)). For \mathcal{S}_{3S} , we use the first part of remark 5 and the fact that the squares b_1^2 , b_2^2 and b_3^2 generate a subgroup of $\widehat{\Gamma}_1^1$ in which $b_1^2 b_2^2 b_3^2$ is central, so that we have $f(b_3^2, b_1^2) f(b_2^2, b_3^2) f(b_1^2, b_2^2) = 1$. A sequence of type \mathcal{S}_{3S} induces conjugation by exactly this element, so the action defined by (3) respects (3S).

The validity of $\mathcal{S}_{6AS} = 1$ is a direct consequence of the defining relation (R) of Λ , which again says that a cycle \mathcal{S}_{6AS} induces conjugation by the unit element. Finally, if \mathcal{S}_1 and \mathcal{S}_2 are disjoint moves in the sense of the definition of (C), then (3) makes them induce a conjugation by elements f_1 and f_2 which commute, because they are prowords on twists over disjoint sets of curves. So $\text{inn}(f_1)$ and $\text{inn}(f_2)$ also commute as automorphisms, as was to be checked. This shows that if we choose a pants decomposition \mathcal{Q} containing β , then the value of $F_{\mathcal{P}}(b)$ is independent of the sequence \mathcal{S} taking \mathcal{P} to \mathcal{Q} .

Now let us show that the value $F_{\mathcal{P}}(b)$ is also independent of the choice of pants decomposition containing β . Let \mathcal{Q} and \mathcal{Q}' be two pants decompositions containing β . If we cut Σ along β , the remaining loops of \mathcal{Q}' and of \mathcal{Q} form pants decompositions of the cut

surface, so there exists a sequence \mathcal{T} of S- and A-moves transforming one into the other. The same sequence \mathcal{T} can be considered as a sequence of S- and A-moves transforming \mathcal{Q}' into \mathcal{Q} on Σ , and involving only moves whose departure and arrival loops are disjoint from β . Now, let \mathcal{S} be a sequence of moves from \mathcal{P} to \mathcal{Q} and \mathcal{S}' a sequence of moves from \mathcal{P} to \mathcal{Q}' . Then we have a new sequence $\mathcal{T}\mathcal{S}'$ from \mathcal{P} to \mathcal{Q} , and by the previous argument, the value of $F_{\mathcal{P}}(b)$ is the same whether the sequence \mathcal{S} or $\mathcal{T}\mathcal{S}'$ is used. However, the value of $F_{\mathcal{P}}(b)$ computed using the sequence $\mathcal{T}\mathcal{S}'$ is given by conjugating b with the f 's corresponding to the moves in \mathcal{T} and those corresponding to the moves in \mathcal{S}' , and all f 's corresponding to the moves in \mathcal{T} commute with b by definition (since the curves involved are disjoint from β). Thus, the value $F_{\mathcal{P}}(b)$ computed by using the pants decomposition \mathcal{Q}' and the sequence \mathcal{S}' is again the same. This concludes the proof. \diamond

Corollary 1. *Let \mathcal{P} and \mathcal{Q} be two pants decompositions of Σ and let $\mathcal{S} = \mathcal{S}_{\beta_r, \gamma_r} \circ \dots \circ \mathcal{S}_{\beta_1, \gamma_1}$ be a finite sequence of S- and A-moves taking \mathcal{P} to \mathcal{Q} . Let $f \in \Lambda$, and set*

$$x = \prod_{i=r}^1 f(b_i^{\varepsilon_i}, c_i^{\varepsilon_i}) \in \widehat{\Gamma}(\Sigma).$$

Then for all Dehn twists b , we have the equality

$$F_{\mathcal{P}}(b) = (\text{inn}(x) \circ F_{\mathcal{Q}})(b).$$

We have proved in this step that the actions of the $F_{\mathcal{P}}$ on Dehn twists are well-defined and related by conjugation; in the following step we will show that they extend to automorphisms of $\widehat{\Gamma}(\Sigma)$.

Step 2. The defining relations of $\widehat{\Gamma}(\Sigma) \simeq \widehat{\Gamma}_{g,n}^m$. In this step, we show that the action of $F_{\mathcal{P}}$ on Dehn twists defined in Step 1 above respects all the defining relations (C), (B), (L) and (D) of $\widehat{\Gamma}(\Sigma)$ (cf. theorem 1). If these relations are respected by $F_{\mathcal{Q}}$ for any pants decomposition \mathcal{Q} , then by corollary 1, they are respected by $F_{\mathcal{P}}$, so it suffices to show that each relation is respected by some $F_{\mathcal{Q}}$ for a suitable choice of \mathcal{Q} .

For (C), suppose β_1 and β_2 are two disjoint loops on Σ and let \mathcal{Q} be a pants decomposition containing both of them. Then by definition, $F_{\mathcal{Q}}(b_1) = b_1$ and $F_{\mathcal{Q}}(b_2) = b_2$, so they commute.

Let us consider braid relations of type (B). Let β_1 and β_2 be loops intersecting in one point, and let \mathcal{Q} be a pants decomposition containing β_1 and not intersecting β_2 . Then the definition above shows that $F_{\mathcal{Q}}(b_1) = b_1$ and $F_{\mathcal{Q}}(b_2) = f(b_2^2, b_1^2)b_2f(b_1^2, b_2^2)$. Let $\gamma = b_1(\beta_2)$. Relation (B) states that $c = b_1b_2b_1^{-1}$. Computing the right-hand side gives

$$\begin{aligned} F_{\mathcal{Q}}(b_1)F_{\mathcal{Q}}(b_2)F_{\mathcal{Q}}(b_1)^{-1} &= b_1f(b_2^2, b_1^2)b_2f(b_1^2, b_2^2)b_1^{-1} \\ &= f(b_1b_2^2b_1^{-1}, b_1^2)b_1b_2b_1^{-1}f(b_1^2, b_1b_2^2b_1^{-1}) \\ &= f(c^2, b_1^2)cf(b_1^2, c^2). \end{aligned}$$

On the other hand, since the loop γ can be obtained from β_1 by a single simple move, the definition of $F_{\mathcal{Q}}$ shows that $F_{\mathcal{Q}}(c) = f(c^2, b_1^2)cf(b_1^2, c^2)$, so that relation (B) is respected by $F_{\mathcal{Q}}$.

Now consider any lantern relation $a_1a_2a_3a_4 = b_1b_2b_3$ in $\widehat{\Gamma}(\Sigma)$, and let \mathcal{Q} be a pants decomposition containing the loops α_i for $1 \leq i \leq 4$ (bounding a subsurface of type $(1, i, j)$ with $i + j = 4$) and β_1 . Then $F_{\mathcal{Q}}(a_i) = a_i$ and $F_{\mathcal{Q}}(b_1) = b_1$, so in particular we have

$$F_{\mathcal{Q}}(a_1)F_{\mathcal{Q}}(a_2)F_{\mathcal{Q}}(a_3)F_{\mathcal{Q}}(a_4) = a_1a_2a_3a_4,$$

so we just have to check that $F_{\mathcal{Q}}$ preserves $b_1b_2b_3$. The loop b_2 is obtained from b_1 by an A-move A_{b_1, b_2} , and b_3 is obtained from b_1 by an A-move A_{b_1, b_3} , so the definition of the action $F_{\mathcal{Q}}$ on b_2 and b_3 gives

$$F_{\mathcal{Q}}(b_2) = f(b_2, b_1)b_2f(b_1, b_2) \quad \text{and} \quad F_{\mathcal{Q}}(b_3) = f(b_3, b_1)b_3f(b_1, b_3).$$

Thus

$$\begin{aligned} F_{\mathcal{Q}}(b_1)F_{\mathcal{Q}}(b_2)F_{\mathcal{Q}}(b_3) &= b_1f(b_2, b_1)b_2f(b_1, b_2)f(b_3, b_1)b_3f(b_1, b_3) \\ &= b_1f(b_2, b_1)b_2f(b_3, b_2)b_3f(b_1, b_3) = a_1a_2a_3a_4 \end{aligned}$$

where the last equality is obtained by using the inverse of equation (1) and the fact that $a_1a_2a_3a_4$ is central.

Finally, we check that all doughnut relations are respected by the action. Let α_1, α_2 and δ be loops as in figure 1(a), so the doughnut relation is $(a_1a_2a_1)^4 = d$. Let \mathcal{Q} be a pants decomposition containing α_1 and δ . Then $F_{\mathcal{Q}}(d) = d$, $F_{\mathcal{Q}}(a_1) = a_1$ and since α_2 is obtained from α_1 by a single S-move, we have $F_{\mathcal{Q}}(a_2) = f(a_2^2, a_1^2)a_2f(a_1^2, a_2^2)$. We compute

$$\begin{aligned} F_{\mathcal{Q}}(a_1)F_{\mathcal{Q}}(a_2)F_{\mathcal{Q}}(a_1) &= a_1f(a_2^2, a_1^2)a_2f(a_1^2, a_2^2)a_1 \\ &= f(a_1a_2^2a_1^{-1}, a_1^2)a_1a_2f(a_1^2, a_2^2)a_1 \\ &= f(a_1a_2^2a_1^{-1}, a_1^2)f(a_2^2, a_1a_2^2a_1^{-1})a_1a_2a_1 \\ &= f(a_2^2, a_1^2)a_1a_2a_1. \end{aligned}$$

The last equality is obtained by applying relation (II), which is legitimate since setting $x = a_1^2$, $y = a_2^2$ and $z = a_1a_2^2a_1^{-1}$, we have $xyz = (a_1a_2)^3$ which commutes with x , y and z . So we have

$$F_{\mathcal{Q}}(a_1)F_{\mathcal{Q}}(a_2)F_{\mathcal{Q}}(a_1) = f(a_2^2, a_1^2)a_1a_2a_1 = a_1a_2a_1f(a_2^2, a_1^2)$$

(the second equality comes from passing the $a_1a_2a_1$ to the left by conjugating the arguments of f), so

$$(F_{\mathcal{Q}}(a_1)F_{\mathcal{Q}}(a_2)F_{\mathcal{Q}}(a_1))^2 = a_1a_2a_1f(a_1^2, a_2^2)f(a_2^2, a_1^2)a_1a_2a_1 = (a_1a_2a_1)^2$$

by relation (I). A fortiori, we find that

$$(F_{\mathcal{Q}}(a_1)F_{\mathcal{Q}}(a_2)F_{\mathcal{Q}}(a_1))^4 = (a_1a_2a_1)^4 = d = F_{\mathcal{Q}}(d).$$

This proves that the action of $F_{\mathcal{P}}$ respects the doughnut relation.

Corollary 2. *Let \mathcal{P} and \mathcal{Q} be two pants decompositions of Σ and let $\mathcal{S} = \mathcal{S}_{\beta_r, \gamma_r} \circ \cdots \circ \mathcal{S}_{\beta_1, \gamma_1}$ be a finite sequence of S- and A-moves taking \mathcal{P} to \mathcal{Q} . Let $f \in \Lambda$, and set*

$$(4) \quad x = \prod_{i=r}^1 f(b_i^{\epsilon_i}, c_i^{\epsilon_i}) \in \widehat{\Gamma}(\Sigma).$$

Then we have an equality of automorphisms $F_{\mathcal{P}} = \text{inn}(x) \circ F_{\mathcal{Q}}$.

PROOF. This follows immediately from corollary 1 since we established in Step 2 that the $F_{\mathcal{P}}$ are automorphisms of $\widehat{\Gamma}(\Sigma)$. \diamond

Step 3. The homomorphism $\psi_{g,n}^m : \Lambda \rightarrow \text{Out}^*(\widehat{\Gamma}(\Sigma))$. In the two previous steps, we defined a map $\psi_{\mathcal{P}} : \Lambda \rightarrow \text{Aut}(\widehat{\Gamma}(\Sigma))$ associated to each pants decomposition \mathcal{P} of Σ . Now we need to show that Λ is a group.

Lemma 7. *Λ is a group.*

PROOF. Consider Λ as a subset of \widehat{GT}^1 . The product of two elements $f, g \in \widehat{GT}^1$ is given by composition of the associated automorphisms of \widehat{F}_2 ; it is given explicitly by

$$(5) \quad h = g \cdot f = g(x, y)f(x, g(y, x)yg(x, y)) = h(x, y).$$

The fact that \widehat{GT}^1 is a group implies that for any $f \in \widehat{GT}^1$, the inverse f^* of f (in the sense of \widehat{GT}^1) also belongs to \widehat{GT}^1 , as does the product $g \cdot f$ for any elements $f, g \in \widehat{GT}^1$. Thus, for all $f, g \in \Lambda$, the inverses of these elements and the compositions $g \cdot f$ lie in \widehat{GT}^1 and satisfy relations (I), (II) and (III). To show that Λ is a subgroup of \widehat{GT}^1 , it remains only to show that for all $f, g \in \Lambda$, f^* and the composition $g \cdot f$ satisfy relation (R).

In Steps 1 and 2 above, we showed that for every $f \in \Lambda$, there exists a family $(F_{\mathcal{P}})_{\mathbf{P}}$ of automorphisms of $\widehat{\Gamma}(\Sigma)$, where \mathbf{P} denotes the family of pants decompositions of Σ , and that the automorphisms $F_{\mathcal{P}}$ are related by corollary 2. Let $g \in \Lambda$ and let $h = g \cdot f \in \widehat{GT}^1$. Set $H_{\mathcal{P}} = G_{\mathcal{P}} \circ F_{\mathcal{P}}$ for every $\mathcal{P} \in \mathbf{P}$. Let us show that corollary 2 remains valid when f is replaced by h and $(F_{\mathcal{P}})_{\mathbf{P}}$ by $(H_{\mathcal{P}})_{\mathbf{P}}$, even though we do not know that $h \in \Lambda$. Suppose that \mathcal{Q} is a pants decomposition obtained from \mathcal{P} by a single S- or A-move taking a loop β to a loop γ . Then by corollary 2, we know that $F_{\mathcal{P}} = \text{inn}(f(b^\epsilon, c^\epsilon))F_{\mathcal{Q}}$, where $\epsilon = 1$ if \mathcal{Q} is obtained from \mathcal{P} by an associativity move and $\epsilon = 2$ if \mathcal{Q} is obtained from \mathcal{P} by a

simple move. We also have $G_{\mathcal{P}} = \text{inn}(g(b^\epsilon, c^\epsilon))G_{\mathcal{Q}}$. Therefore, we find that

$$\begin{aligned}
H_{\mathcal{P}} &= G_{\mathcal{P}} \circ F_{\mathcal{P}} = \text{inn}(g(b^\epsilon, c^\epsilon)) \circ G_{\mathcal{Q}} \circ \text{inn}(f(b^\epsilon, c^\epsilon)) \circ F_{\mathcal{Q}} \\
&= \text{inn}(g(b^\epsilon, c^\epsilon)) \circ \text{inn}(G_{\mathcal{Q}}(f(b^\epsilon, c^\epsilon))) \circ G_{\mathcal{Q}} \circ F_{\mathcal{Q}} = \text{inn}(G_{\mathcal{Q}}(f(b^\epsilon, c^\epsilon))g(b^\epsilon, c^\epsilon)) \circ H_{\mathcal{Q}} \\
&= \text{inn}(f(G_{\mathcal{Q}}(b^\epsilon), G_{\mathcal{Q}}(c^\epsilon))g(b^\epsilon, c^\epsilon)) \circ H_{\mathcal{Q}} = \text{inn}(f(g(b^\epsilon, c^\epsilon)b^\epsilon g(c^\epsilon, b^\epsilon), c^\epsilon)g(b^\epsilon, c^\epsilon)) \circ H_{\mathcal{Q}} \\
&= \text{inn}(g(b^\epsilon, c^\epsilon)f(b^\epsilon, g(c^\epsilon, b^\epsilon)c^\epsilon g(b^\epsilon, c^\epsilon))) \circ H_{\mathcal{Q}} \\
&= \text{inn}(h(b^\epsilon, c^\epsilon)) \circ H_{\mathcal{Q}}.
\end{aligned}$$

Taking sequences of moves, we find that corollary 2 is valid for $(H_{\mathcal{P}})_{\mathbf{P}}$.

Now, consider the case where $\Sigma = \Sigma_1^2$. The group $\Gamma(\Sigma_1^2)$ is isomorphic to B_4/Z , the quotient of the Artin braid group on four strands modulo its center. Let \mathcal{P} be the pants decomposition of Σ_1^2 given by the loops α_1 and α_3 shown in figure 5, and let $\mathcal{Q} = \mathcal{P}$. Then the sequence of moves (6AS) takes \mathcal{P} to \mathcal{Q} (i.e. to itself). Thus by corollary 2 applied to the family $(H_{\mathcal{P}})_{\mathbf{P}}$, we find that

$$H_{\mathcal{P}} = \text{inn}(h(e_3, a_1)h(a_2^2, a_3^2)h(e_2, e_3)h(e_1, e_2)h(a_1^2, a_2^2)h(a_3, e_1))H_{\mathcal{P}}.$$

Thus the element $h(e_3, a_1)h(a_2^2, a_3^2)h(e_2, e_3)h(e_1, e_2)h(a_1^2, a_2^2)h(a_3, e_1)$ lies in the center of $\widehat{\Gamma}_1^2$. However, each factor of this expression belongs to the derived subgroup of $\widehat{\Gamma}_1^2$, and the intersection of the derived subgroup with the center (generated by the Dehn twists along the two boundary components) is trivial.

We have shown that if $f, g \in \Lambda$, then $h = g \cdot f \in \Lambda$. To show that Λ is a group, it remains only to show that if $f \in \Lambda$, then f^* is also in Λ . This time we consider the family $(F_{\mathcal{P}}^{-1})_{\mathbf{P}}$. We know that

$$F_{\mathcal{P}} = \text{inn}(f(b^\epsilon, c^\epsilon)) \circ F_{\mathcal{Q}};$$

and inverting this formula gives

$$F_{\mathcal{P}}^{-1} = F_{\mathcal{Q}}^{-1} \circ \text{inn}(f(c^\epsilon, b^\epsilon)) = \text{inn}(F_{\mathcal{Q}}^{-1}(f(c^\epsilon, b^\epsilon))) \circ F_{\mathcal{Q}}^{-1} = \text{inn}(f^*(b^\epsilon, c^\epsilon)) \circ F_{\mathcal{Q}}^{-1}.$$

Indeed, f^* is defined by $f^*(x, y)F^{-1}(f(x, y)) = 1$ with $F(x) = x$ and $F(y) = f(y, x)yf(x, y)$, so under the homomorphism $x \mapsto c$ and $y \mapsto b$, F corresponds to $F_{\mathcal{Q}}$ and we have $f^*(b^\epsilon, c^\epsilon) = F_{\mathcal{Q}}^{-1}(f(c^\epsilon, b^\epsilon))$. As for h above, using the cycle (6AS) in $\widehat{\Gamma}_{1,2}$ to bring \mathcal{P} to $\mathcal{Q} = \mathcal{P}$, we find that

$$f^*(e_3, a_1)f^*(a_2^2, a_3^2)f^*(e_2, e_3)f^*(e_1, e_2)f^*(a_1^2, a_2^2)f^*(a_3, e_1) = 1,$$

so $f^* \in \Lambda$. This concludes the proof that Λ is a group and also that for each pants decomposition \mathcal{P} , $\psi_{\mathcal{P}} : \Lambda \rightarrow \widehat{\Gamma}(\Sigma)$ is a group homomorphism. \diamond

Let us conclude the proof of theorem 4. The fact that the automorphisms $\psi_{\mathcal{P}}(f)$ of $\widehat{\Gamma}_{g,n}^m$ are all equivalent modulo inner automorphisms is an immediate consequence of formula (4) in Corollary 2. Furthermore, the image of Λ in $\text{Out}(\widehat{\Gamma}_{g,n}^m)$ obviously lies in $\text{Out}^*(\widehat{\Gamma}_{g,n}^m)$ since by construction, Dehn twists are sent to conjugates of themselves under the action of $\psi_{\mathcal{P}}(f)$, so that as outer automorphisms, the $\psi_{\mathcal{P}}(f)$ preserve conjugacy classes of Dehn twists. \diamond

PROOF OF THEOREM 5. Let us show that the map

$$(6) \quad f \mapsto \mathcal{F} = (\psi_{g,n}^m(f))_{(g,n,m)}$$

defines an injective group homomorphism from Λ to $\text{Out}^*(\mathcal{T})$. We know from theorem 4 that each $\psi_{g,n}^m$ is a group homomorphism from Λ to $\text{Out}^*(\widehat{\Gamma}_{g,n}^m)$. To see that \mathcal{F} is an automorphism of \mathcal{T} , we need to check that the $\psi_{g,n}^m(f)$ commute with the homomorphisms belonging to the Teichmüller tower \mathcal{T} associated to the cutting out of a subsurface of $\Sigma_{g,n}^m$ along loops of \mathcal{P} . But this is an immediate consequence of the local properties of the liftings $F_{\mathcal{P}} = \psi_{\mathcal{P}}(f)$ of $\psi_{g,n}^m(f)$ to $\text{Aut}(\widehat{\Gamma}(\Sigma))$. Thus we obtain a group homomorphism from Λ to $\text{Out}^*(\mathcal{T})$. To see that it is injective, it suffices to note that the group homomorphism $\psi_{0,4} : \Lambda \rightarrow \text{Out}^*(\widehat{\Gamma}_{0,4})$ is already injective. Indeed, if $\psi_{0,4}(f) = 1$, then for any pants decomposition \mathcal{P} of $\Sigma_{0,4}$, $F_{\mathcal{P}} = \psi_{\mathcal{P}}(f)$ is an inner automorphism of $\widehat{\Gamma}_{0,4}$. But this automorphism is given by $b_1 \mapsto b_1$ and $b_2 \mapsto f(b_2, b_1)b_2f(b_1, b_2)$ where b_1 and b_2 are generators of $\widehat{\Gamma}_{0,4}$, and since $\widehat{\Gamma}_{0,4}$ is a free group and $f \in \widehat{F}_2'$, we must have $f = 1$. \diamond

References

- [B] J. Birman, *Braids, links, and mapping class groups*, Ann. of Math. Studies, vol. **82**, Princeton Univ. Press, 1975.
- [D] V.G. Drinfel'd, On quasitriangular quasi-Hopf algebras and a group closely connected with $\text{Gal}(\overline{\mathbb{Q}}/\mathbb{Q})$, *Leningrad Math. J.* **2** (1991), 829-860.
- [FL] Feng Luo, A presentation of the mapping class group, *Math. Res. Lett.* **4**, 1997, 735-739.
- [G] S. Gervais, Presentation and central extensions of mapping class groups, *Trans. Amer. Math. Soc.* **348**, No. 8 (1996), 3097-3132.
- [GGA] *Geometric Galois Actions*, L.Schneps and P.Lochak eds., London Math. Soc. Lecture Notes **242**, Cambridge University Press, 1997.
- [HT] A. Hatcher, W. Thurston, A presentation for the mapping class group of a closed orientable surface, *Topology* **19** (1980), 221-237.
- [I] Y.Ihara, Embedding of $G_{\mathbb{Q}}$ into \widehat{GT} , in *The Grothendieck theory of dessins d'enfants*, L.Schneps ed., London Math. Soc. Lecture Notes **200**, Cambridge University Press, 1994, 289-305.
- [IM] Y.Ihara and M.Matsumoto, On Galois actions on profinite completions of braid groups, in *Recent developments in the inverse Galois problem*, Contemp. Math. **186**, M.Fried et al. eds, 1995, 173-200.
- [L] P. Lochak, The fundamental groups at infinity of the moduli spaces of curves, in [GGA], 139-158.
- [LNS] P. Lochak, H. Nakamura, L. Schneps, On a new version of the Grothendieck-Teichmüller group, *Note aux C.R.A.S., Série I* **325** (1997), 11-16.
- [LS] P. Lochak, L. Schneps, The Grothendieck-Teichmüller group and automorphisms of braid groups, in *The Grothendieck Theory of Dessins d'Enfants*, London Math. Soc. Lecture Notes **200**, Cambridge University Press, 1994.
- [NS] H.Nakamura, L. Schneps, On a subgroup of the Grothendieck-Teichmüller group acting on the tower of profinite Teichmüller modular groups, to appear in *Invent. Math.*.
- [O] T. Oda, Etale homotopy type of the moduli spaces of algebraic curves, in [GGA], 85-95.
- [PS] *Espaces de modules de courbes, groupes modulaires et théorie des champs*, L.Schneps ed., Panoramas et Synthèses **7**, SMF Publ., 1998.

Allen Hatcher, hatcher@math.cornell.edu

Mathematics Department, Cornell University, White Hall, Ithaca, NY 14853-0001, USA

Pierre Lochak, lochak@dmi.ens.fr

DMI, Ecole Normale Supérieure, 45 rue d'Ulm, 75005 Paris, France

Leila Schneps, schneps@dmi.ens.fr

Laboratoire de Mathématiques, Faculté des Sciences de Besançon, 25030 Besançon Cedex, France