

Geometry and dynamics in moduli spaces

Lecture 11. Arnold's Problem on interval exchange permutations

Anton Zorich
Université Paris Cité

April 7, 2026

Arnold and Sinai

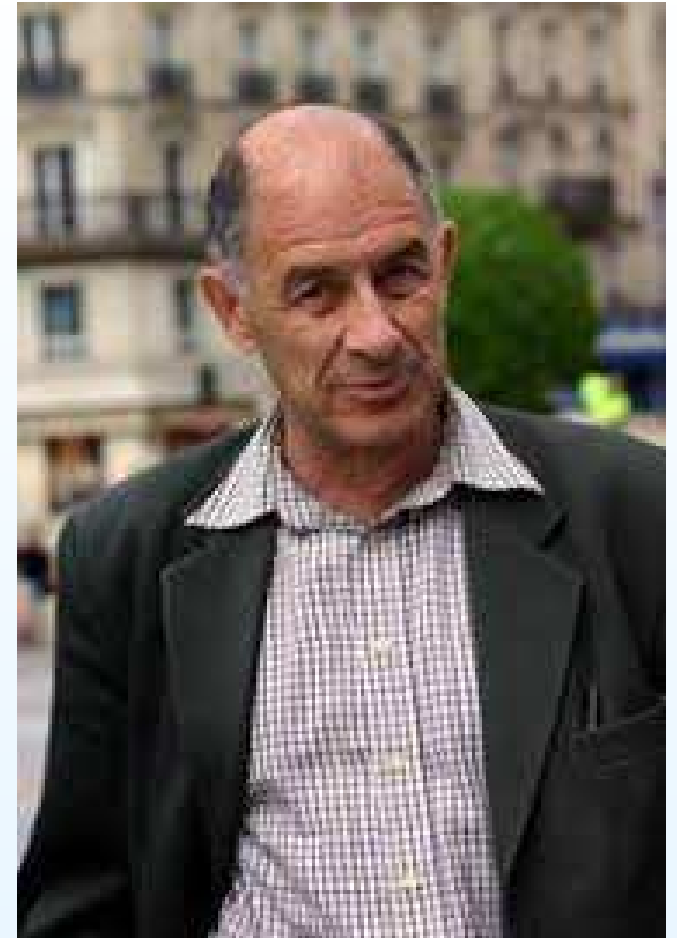

Left picture: Vladimir Arnold and Yakov Sinai; the picture is taken by Jurgen Moser in 1963 on the stairs of Moscow State University.

Right picture: Vladimir Arnold, I bet, in Paris.

Arnold's problem

- Arnold's problem
- Non-cyclic example
- Cyclic nontransitive example
- Transitive example
- Suspension flow on the flat torus
- Interval exchange as the first return map
- Count of square-tiled tori
- Asymptotic proportions

Approach to Arnold's problem

Explicit answers for low dimensional strata

Stratification of the moduli space of holomorphic 1-forms

Arnold's problem

Arnold's problem

2002-8. The (C, B, A) -permutation of the set $\{1, 2, \dots, n\}$ transports to the last place the subset $A = \{1, 2, \dots, a\}$ preceded by the transported set $B = \{a + 1, \dots, a + b\}$ while the starting position is occupied by $C = \{a + b + 1, \dots, n\}$.

Some of these $(n - 1)(n - 2)/2$ permutations permute *cyclically* (like the addition of a constant to the residues mod n), and some of these cyclic permutations are *transitive* (like the addition of the constant 1).

Find the proportion of both the cyclic and the transitive cyclic permutations among the (C, B, A) -permutations for large n .

More generally, starting from a permutation of k elements, one defines a permutation of the set $\{1, \dots, n\}$ from its decomposition into k segments $\{a_i + 1, a_{i+1} - 1\}$. The problem is to study the statistics of the Young diagrams formed by the cycle lengths of the resulting permutations, for the case of large n and random decompositions of n into k parts.

Example of a non-cyclic (C,B,A)-permutation



Let us chop the interval $X = [0, n[$ into three subintervals

$X_A = [0, a[$, $X_B = [a + 1, a + b[$, and $X_C = [a + b + 1, n[$.

In our example $A = \{1, 2\}$, $B = \{3, 4, 5, 6\}$, $C = \{7, 8, 9, 10, 11\}$.

Example of a non-cyclic (C,B,A)-permutation

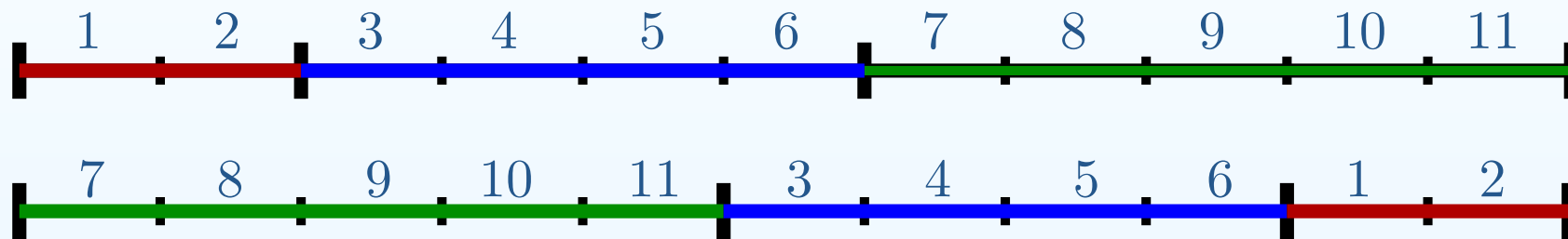

The decomposition a (C, B, A) -permutation into disjoint cycles can be studied through the interval exchange transformation placing the subintervals in the order X_C, X_B, X_A and mapping the resulting interval to the original interval X by isometry.

Example of a non-cyclic (C,B,A)-permutation

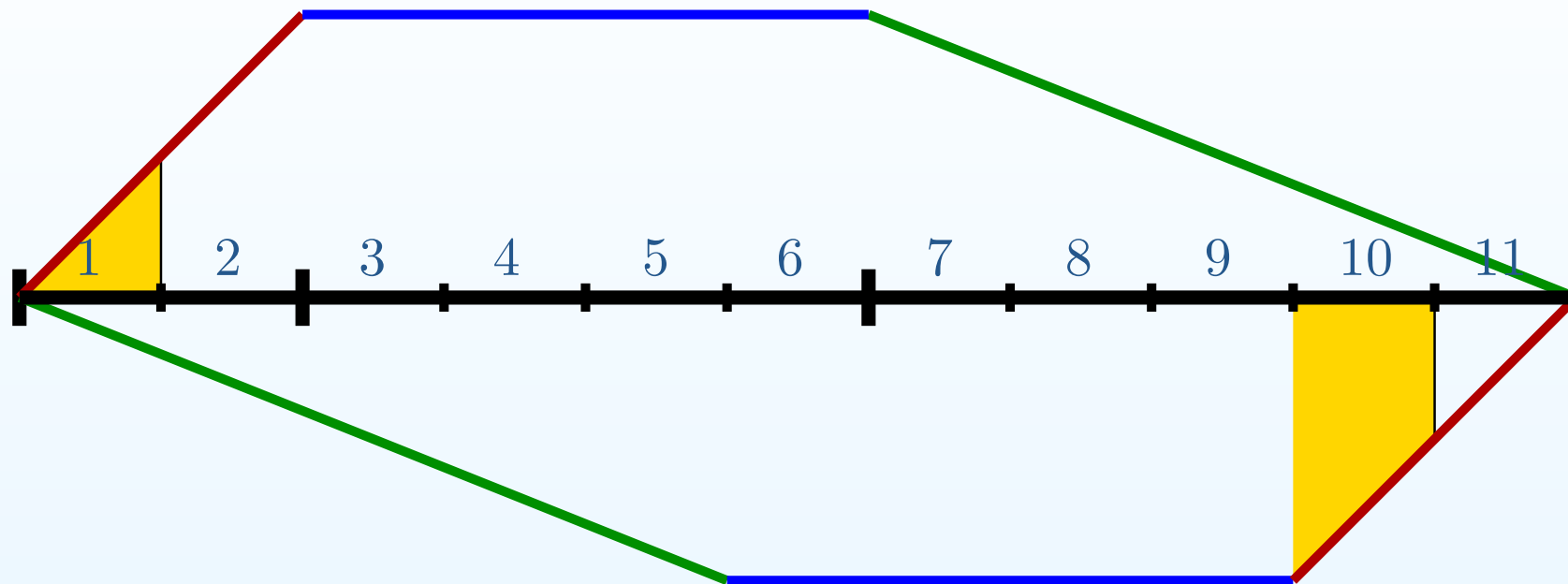

It is convenient to use a suspension over the interval exchange transformation to study its orbits. We get

$$1 \mapsto 10$$

Example of a non-cyclic (C,B,A)-permutation

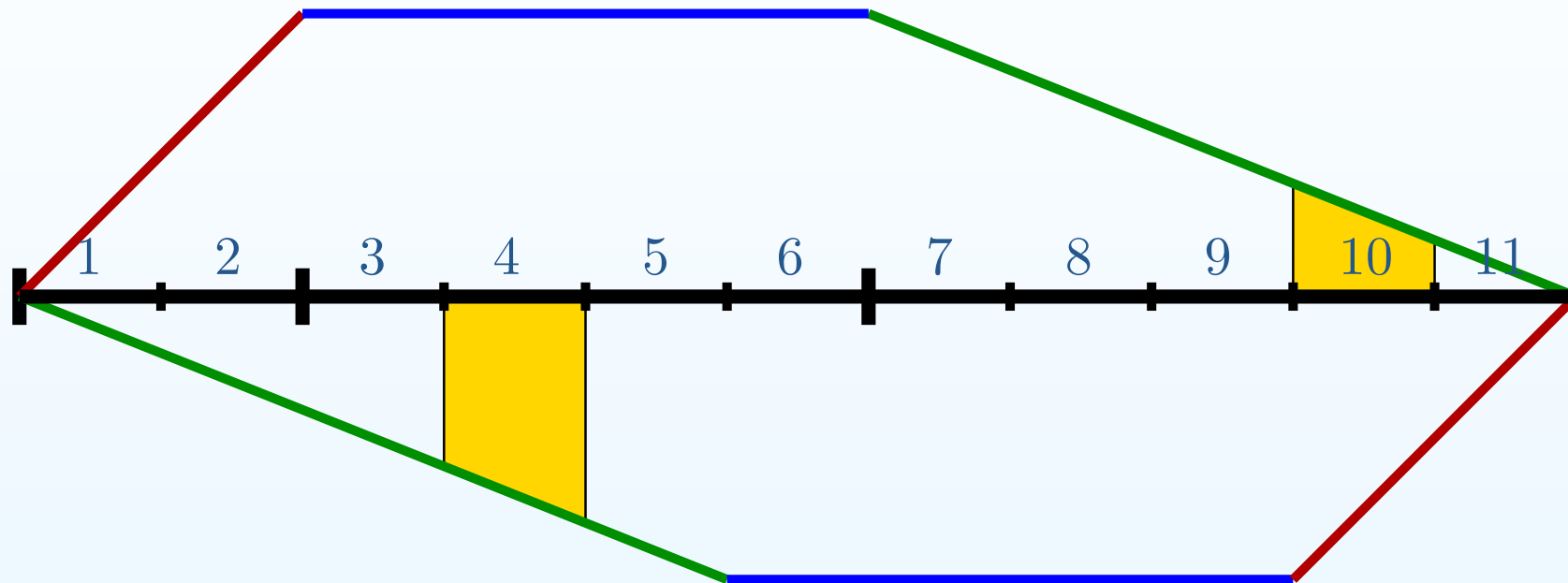

It is convenient to use a suspension over the interval exchange transformation to study its orbits. We get

$$1 \mapsto 10 \mapsto 4$$

Example of a non-cyclic (C,B,A)-permutation

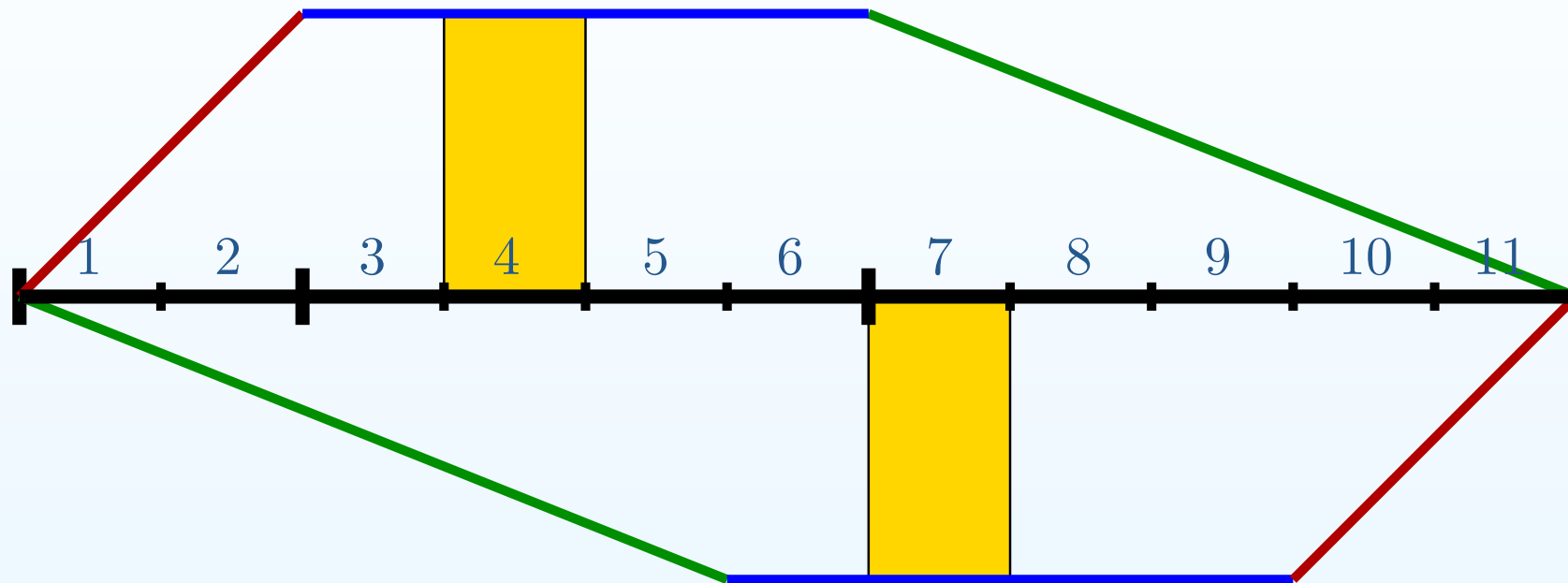

It is convenient to use a suspension over the interval exchange transformation to study its orbits. We get

$$1 \mapsto 10 \mapsto 4 \mapsto 7$$

Example of a non-cyclic (C,B,A)-permutation

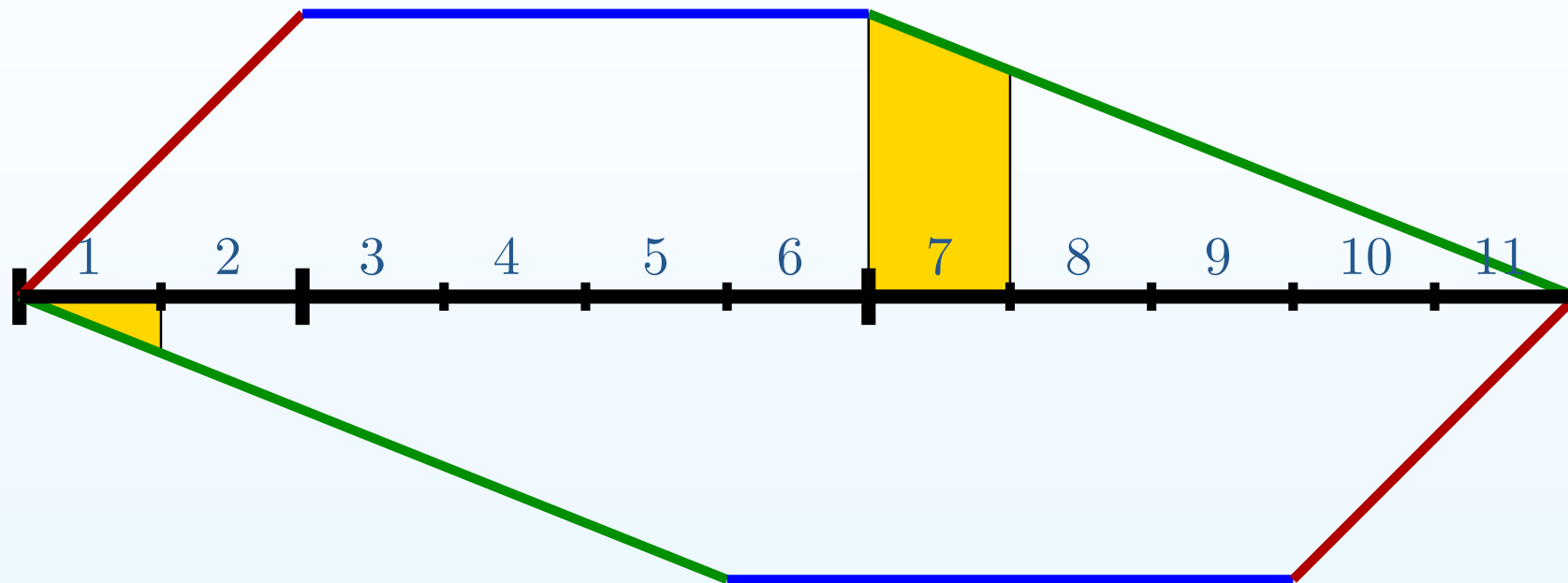

It is convenient to use a suspension over the interval exchange transformation

to study its orbits. We get

$1 \mapsto 10 \mapsto 4 \mapsto 7 \mapsto$

and the first cycle closes up.

Example of a non-cyclic (C,B,A)-permutation

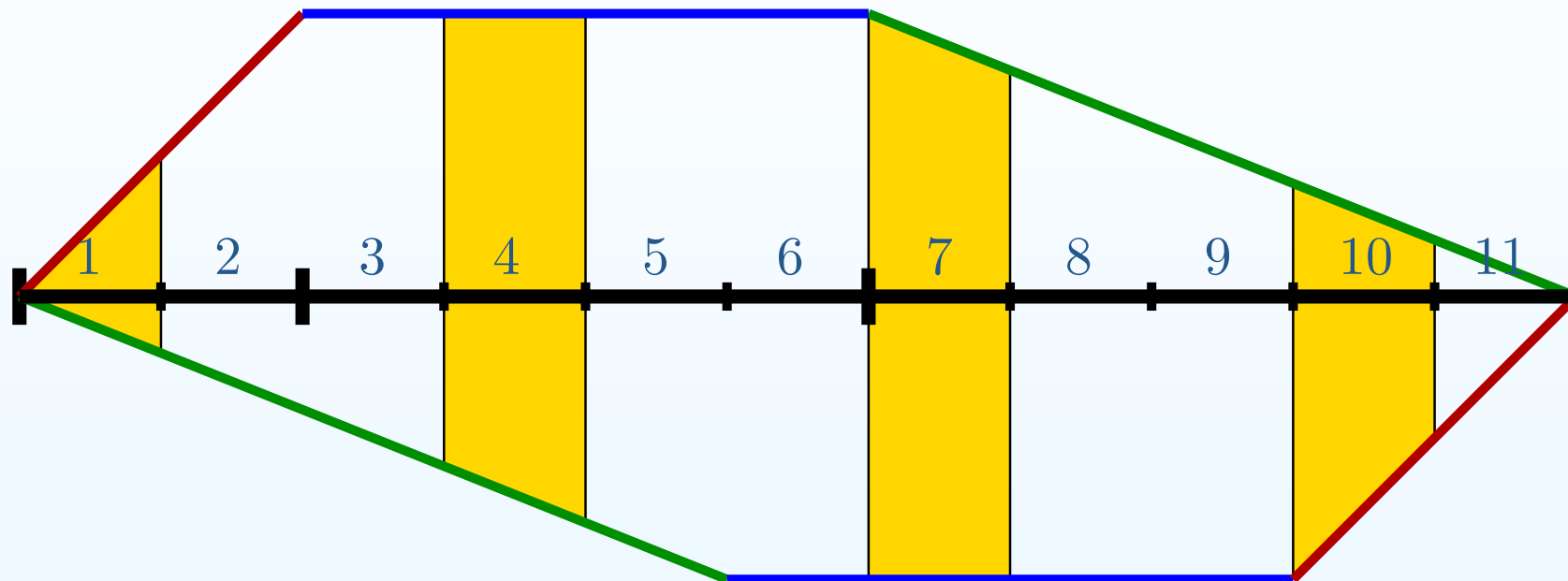

It is convenient to use a suspension over the interval exchange transformation

to study its orbits. We get

$1 \mapsto 10 \mapsto 4 \mapsto 7 \mapsto$

and the first cycle closes up.

Example of a non-cyclic (C,B,A)-permutation

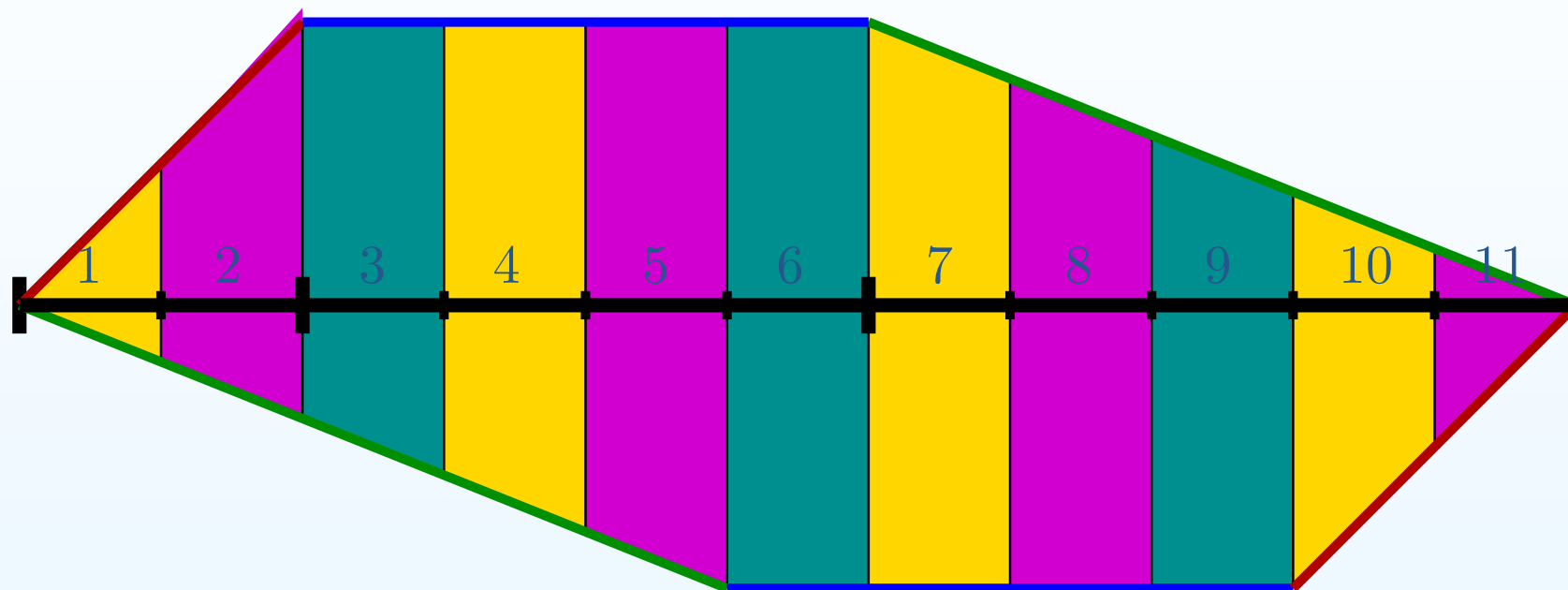

In a similar way we get the complete cyclic decomposition of our permutation:

$$(1, 10, 4, 7)(2, 11, 5, 8)(3, 6, 9).$$

We considered the example, where $|A| = 2$, $|B| = 4$, $|C| = 5$, and observed that the resulting (C, B, A) -permutation is not “cyclic” in the sense of Arnold (and, hence, also non transitive).

Example of a cyclic but nontransitive (C,B,A)-permutation

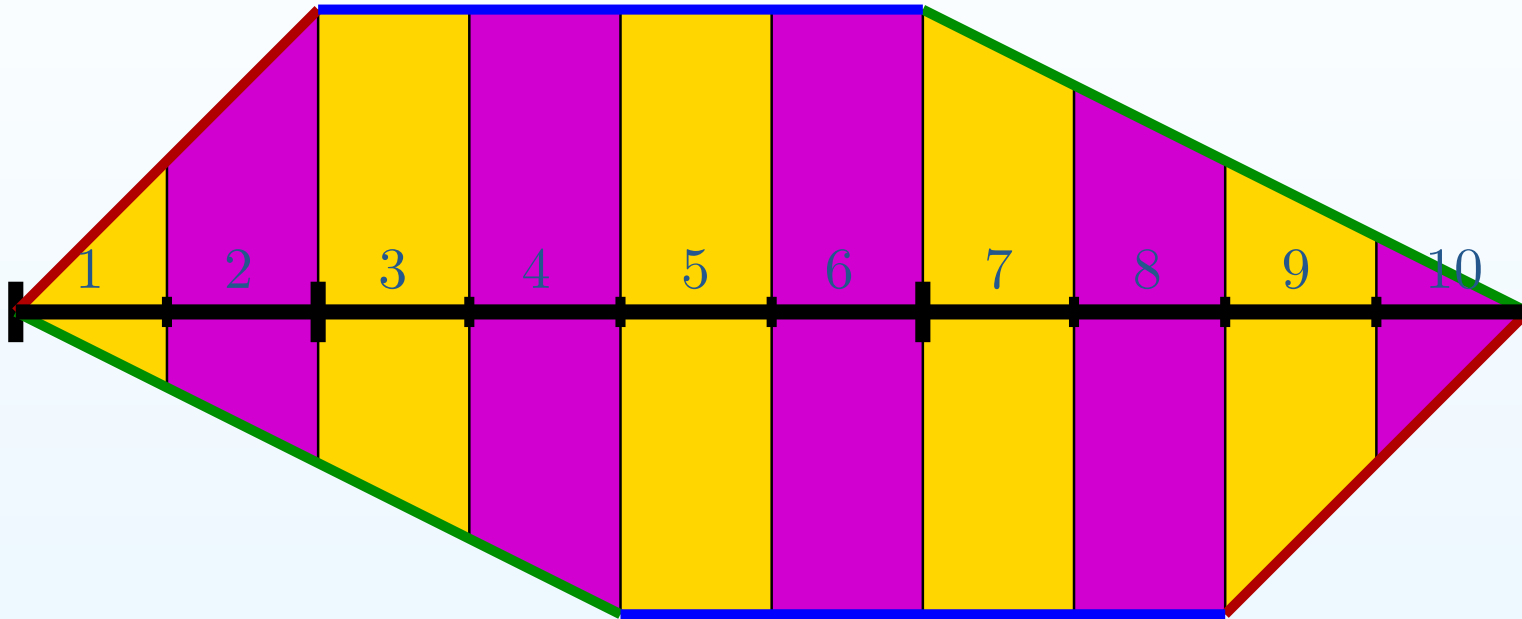

Choosing $|A| = 2$, $|B| = 4$, $|C| = 4$ we get the following cyclic decomposition of the resulting (C, B, A) -permutation:

$$(1, 9, 3, 5, 7)(2, 10, 4, 6, 8)$$

Forgetting the ordering in the two cycles, we get two unordered sets

$$\{1, 3, 5, 7, 9\} \sqcup \{2, 4, 6, 8, 10\},$$

which mimic orbits of a cyclic permutation (as when adding the constant 2).

However, since there are two distinct orbits and not a single orbit, this permutation is “cyclic” but not “transitive” in the sense of Arnold.

Example of a transitive (C,B,A)-permutation

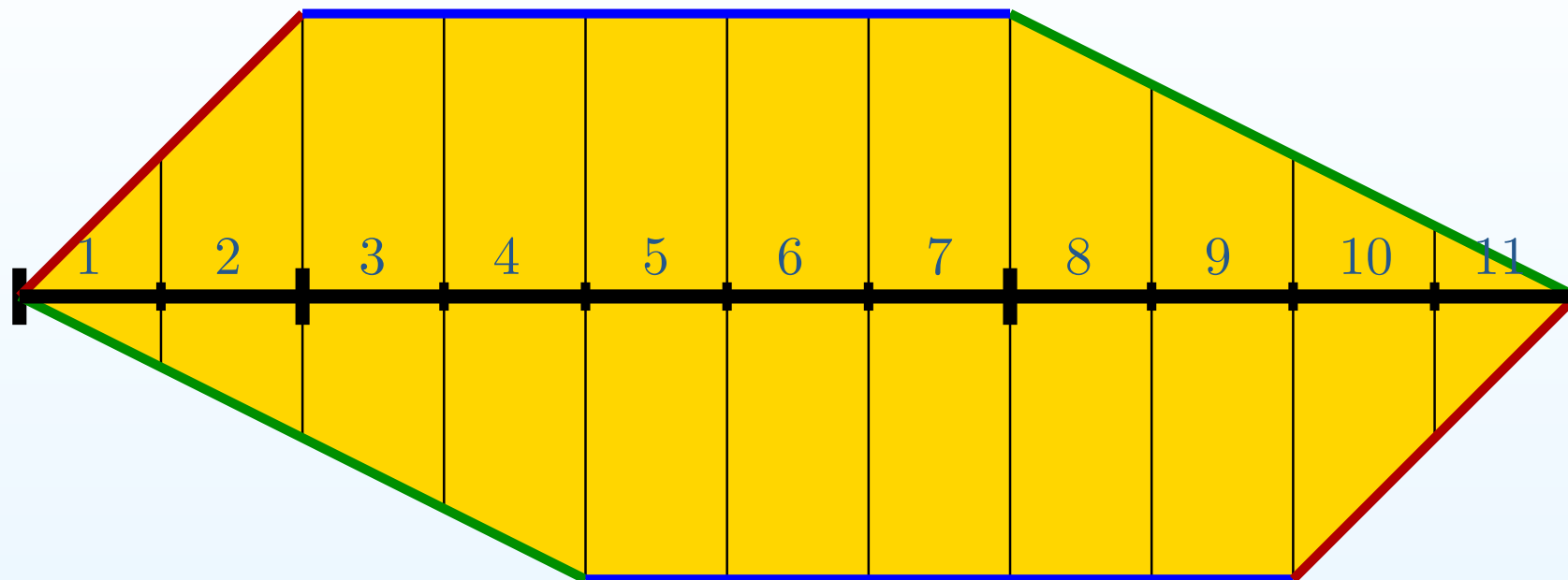

Choosing $|A| = 2$, $|B| = 5$, $|C| = 4$ we get the following cyclic decomposition of the resulting (C, B, A) -permutation:

$$(1, 10, 3, 5, 7, 9, 2, 11, 4, 6, 8)$$

Our permutation acts transitively on the set $\{1, \dots, 11\}$. This permutation is “transitive” in the sense of Arnold.

Suspension flow on the flat torus

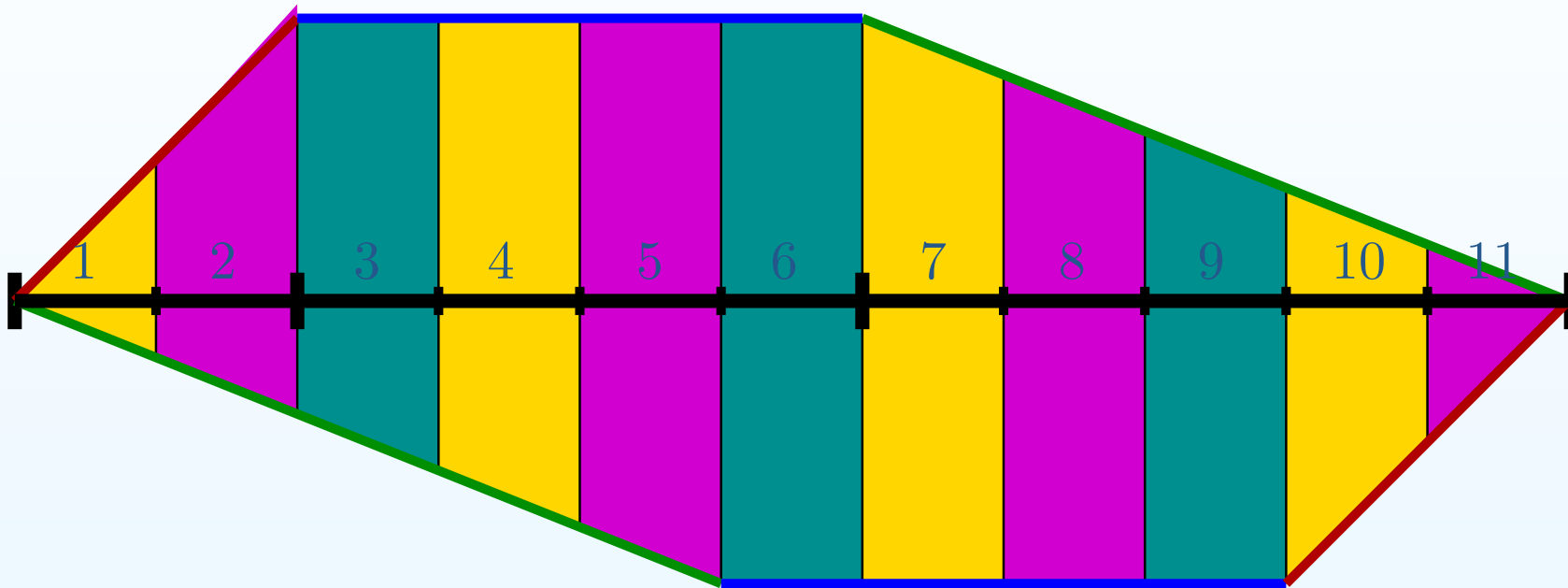

Let us look a bit more attentively at the suspension flow over the interval exchange transformation on the resulting flat surface.

Suspension flow on the flat torus

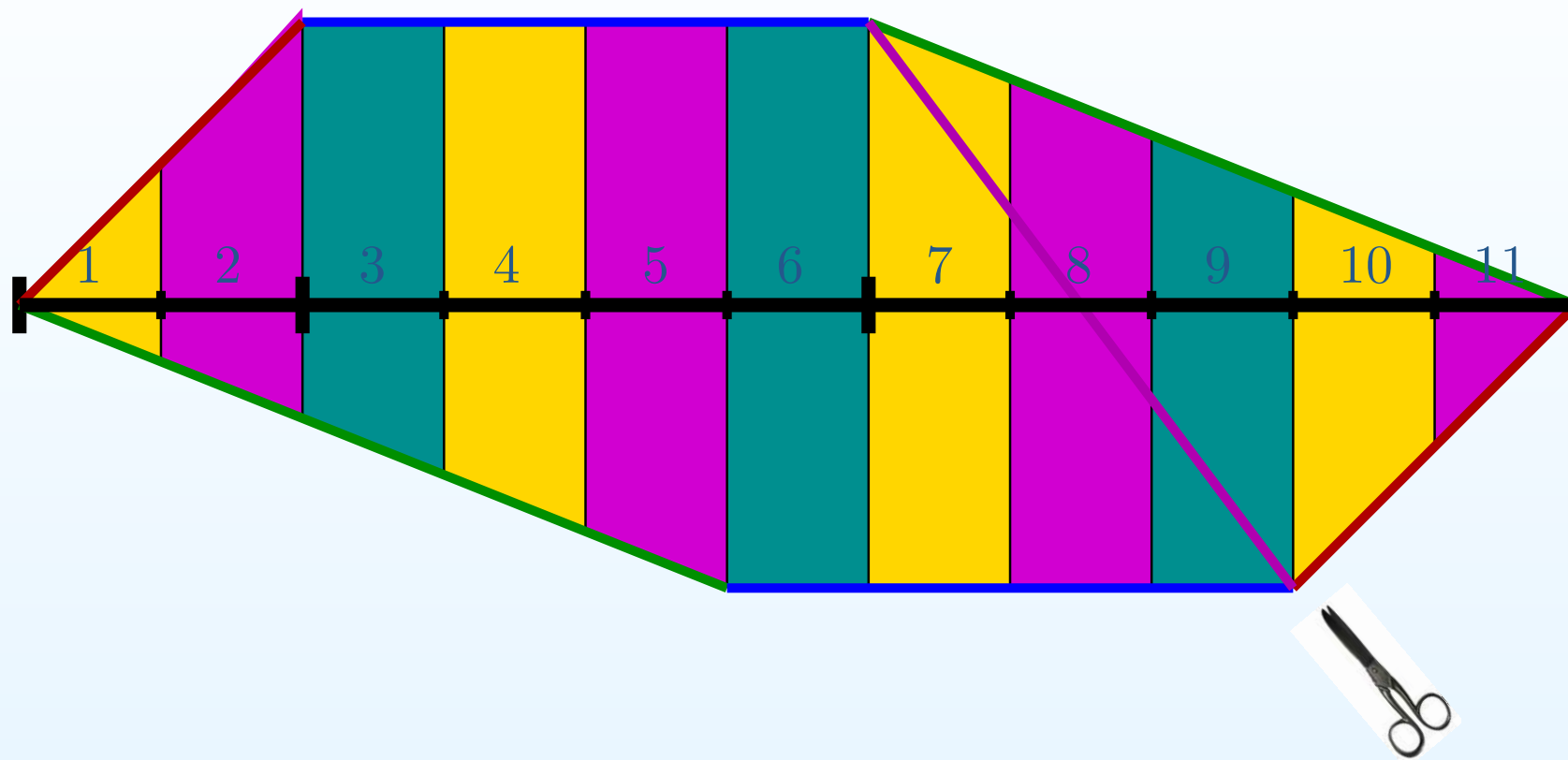

Let us look a bit more attentively at the suspension flow over the interval exchange transformation on the resulting flat surface. For this we modify the polygonal pattern of the surface by cutting a triangle on the right and placing it on the left.

Suspension flow on the flat torus

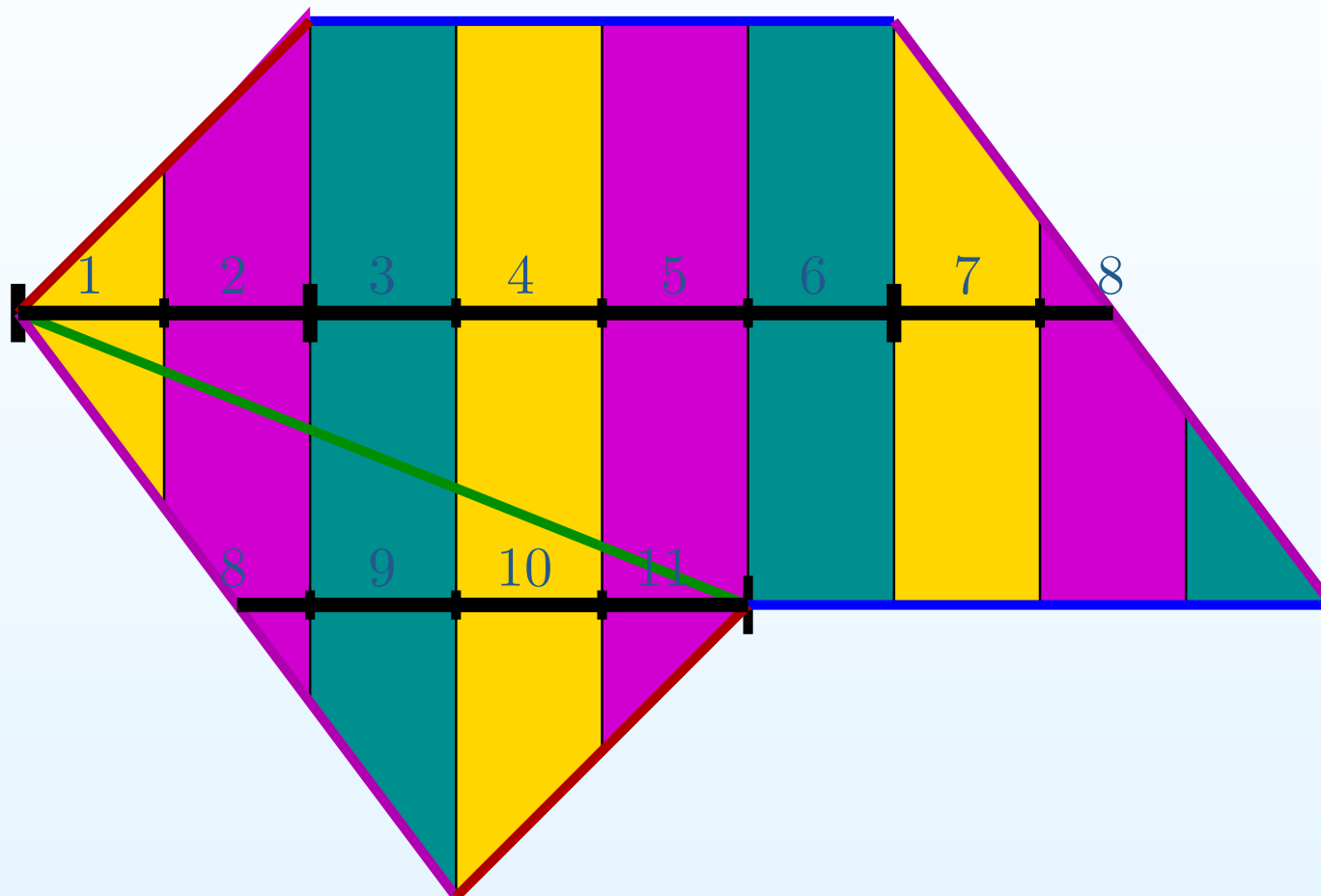

Let us look a bit more attentively at the suspension flow over the interval exchange transformation on the resulting flat surface. For this we modify the polygonal pattern of the surface by cutting a triangle on the right and placing it on the left.

Suspension flow on the flat torus

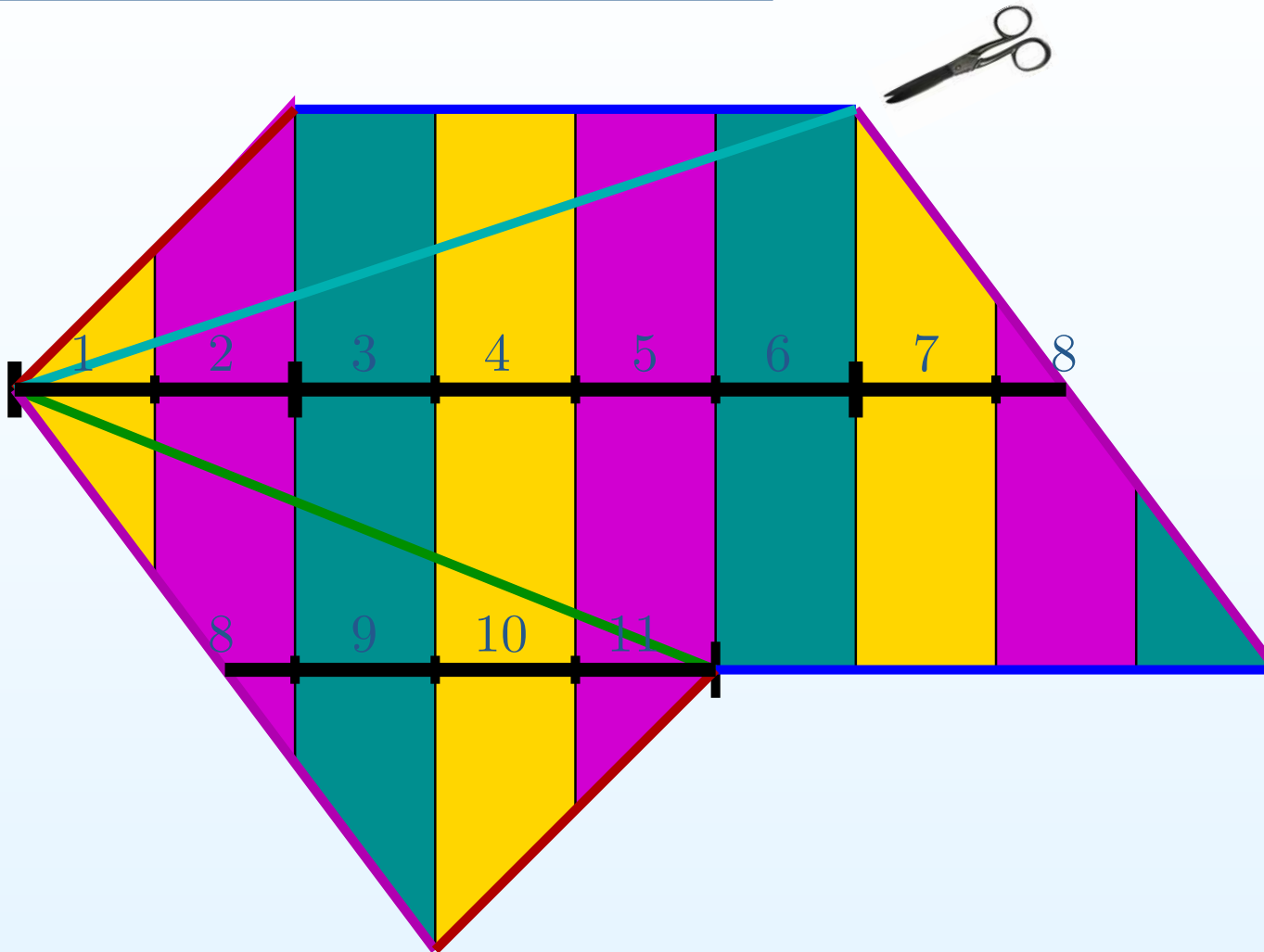

And then we chop and paste one more triangle

Suspension flow on the flat torus

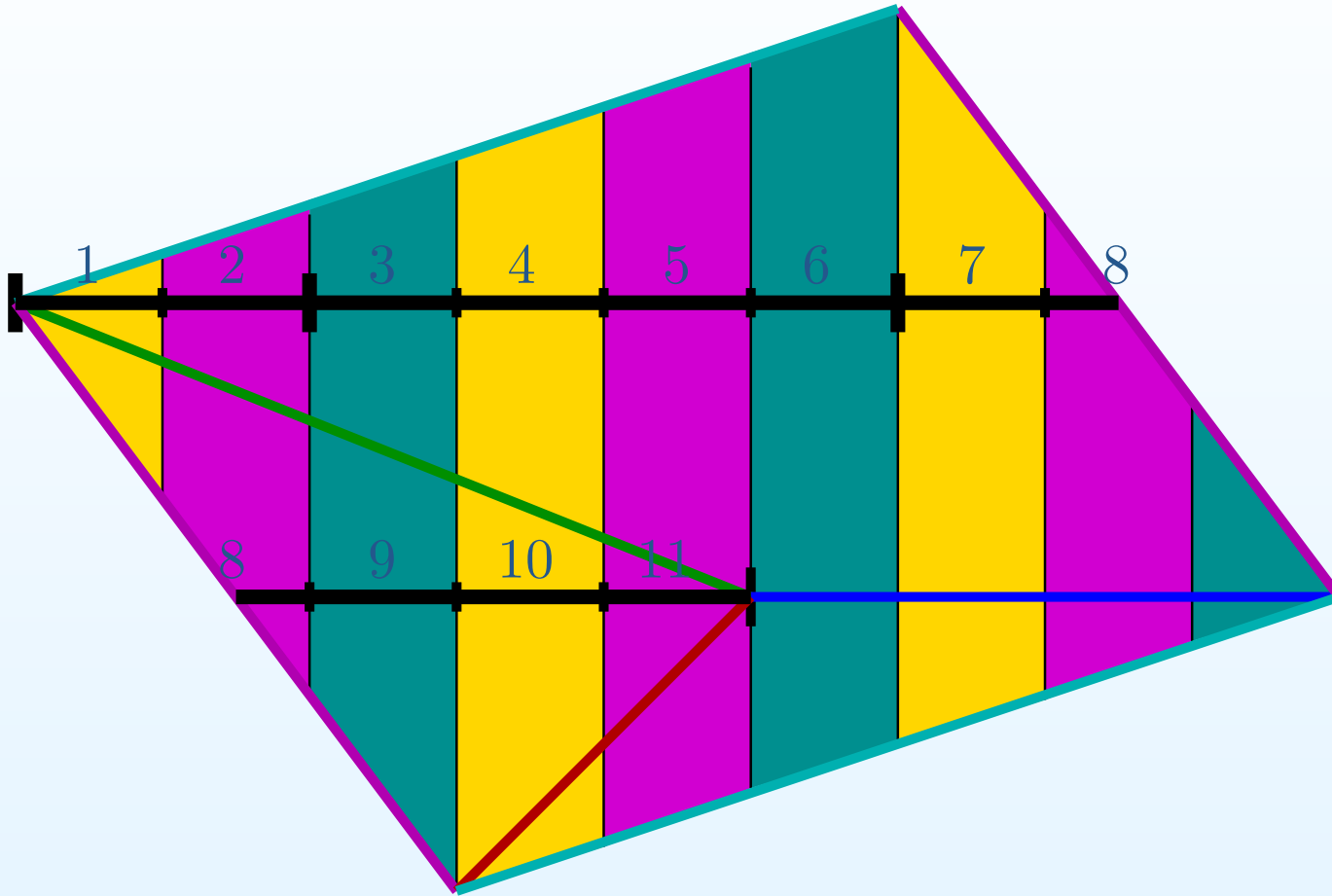

And then we chop and paste one more triangle

Suspension flow on the flat torus

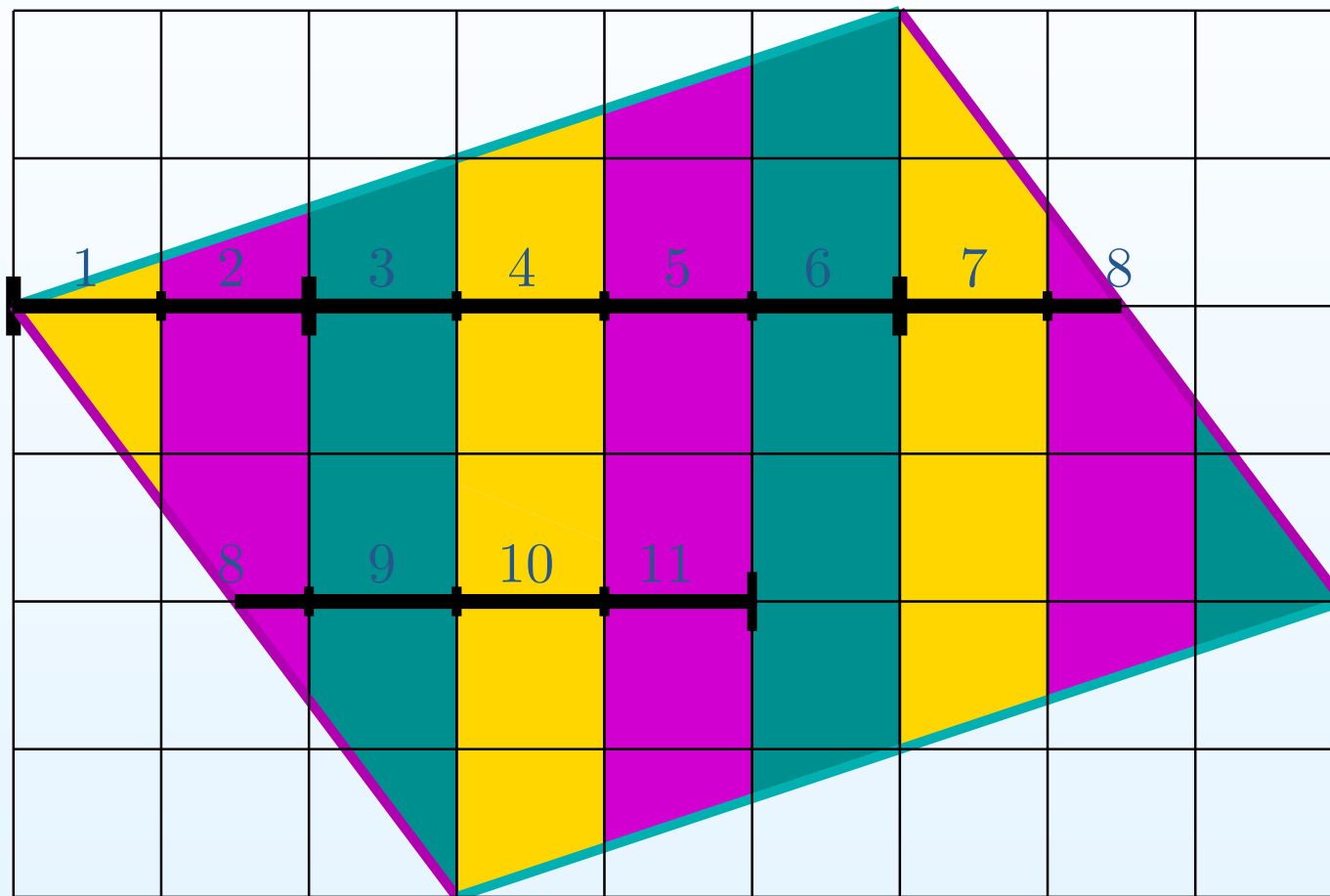

Placing the vertices of the suspension at the points of the lattice $\mathbb{Z} \oplus \mathbb{Z} \subset \mathbb{R}^2$, we get the completely periodic vertical flow on a flat torus with integral sides.

Suspension flow on the flat torus

It is convenient to represent the torus as a cylinder filled with closed vertical trajectories with twisted identification of the vertical boundary circles. We recover once again the decomposition of our permutation into disjoint cycles:

$$(1, 10, 4, 7)(2, 11, 5, 8)(3, 6, 9).$$

In this case it is non-cyclic, because the endpoints of the interval belong to distinct vertical leaves.

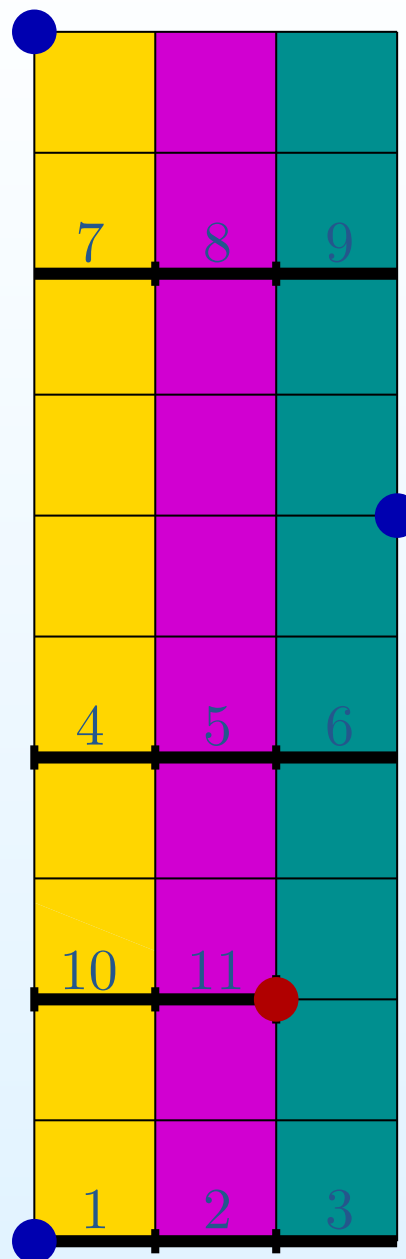

Suspension flow on the flat torus

The picture on the right illustrates the vertical flow on the torus corresponding to the second permutation, having the cyclic structure

$$(1, 9, 3, 5, 7)(2, 10, 4, 6, 8).$$

In this case of cyclic but non-transitive permutation both endpoints of the interval belong to the same vertical leaf, but the torus is composed of several (in our case two) vertical bands of squares.

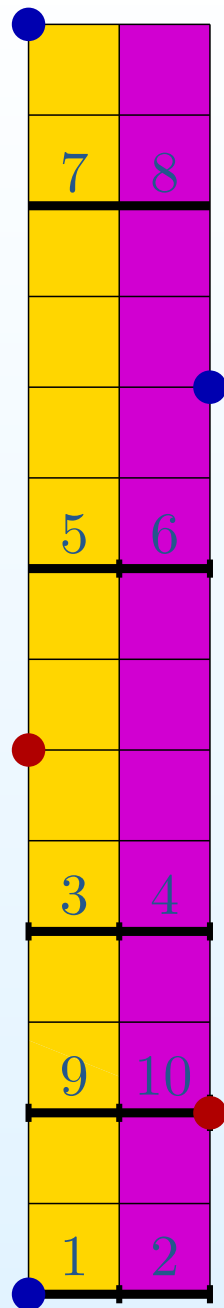

Suspension flow on the flat torus

The last picture illustrates the vertical flow on the torus corresponding to the transitive permutation, having the cyclic structure

$$(1, 10, 3, 5, 7, 9, 2, 11, 4, 6, 8).$$

In this case the torus is composed of a single vertical band of squares. Both endpoints of the interval under exchange necessarily belong to the same vertical leaf.



Interval exchange as the first return map

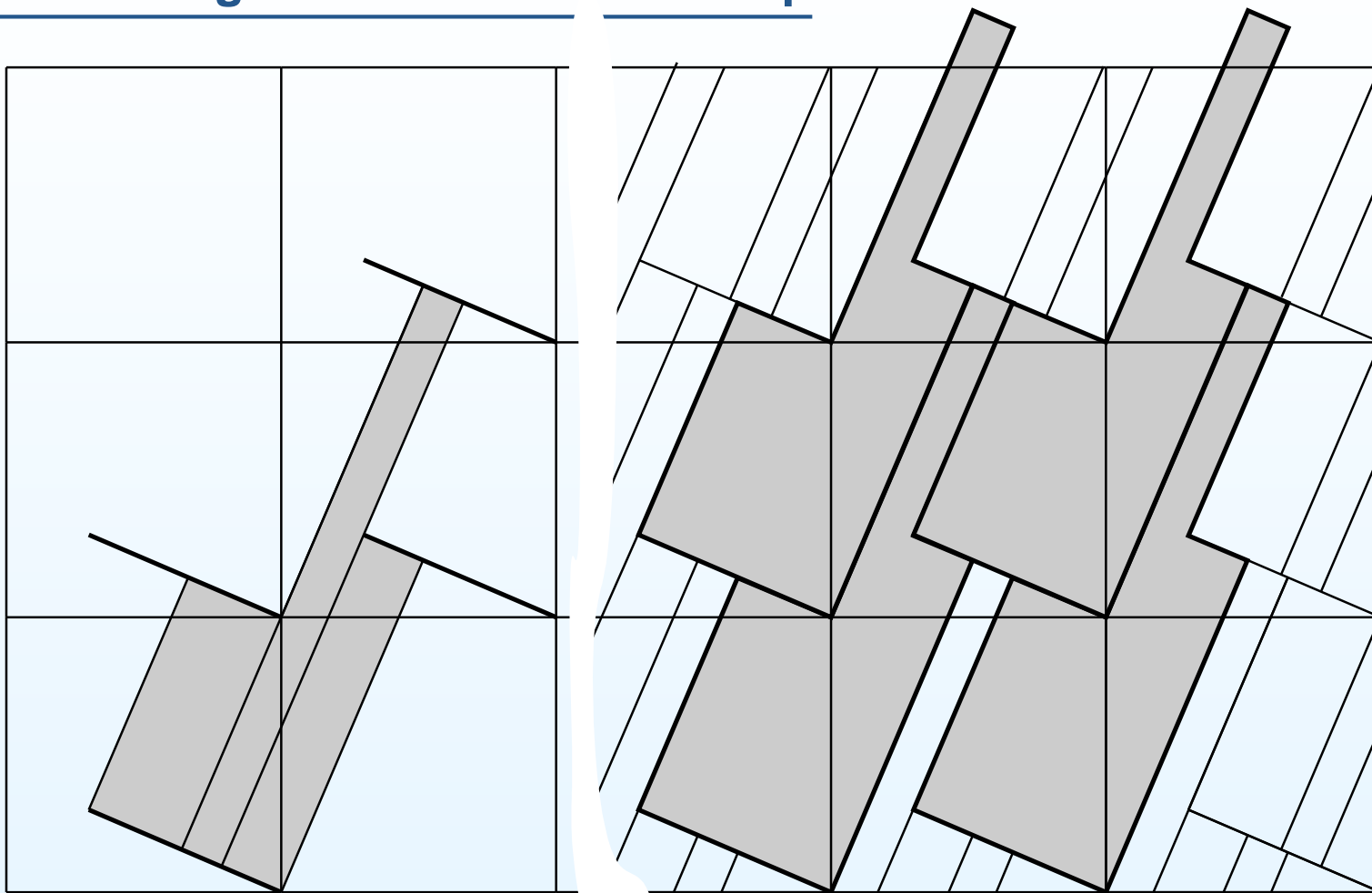

Directional flow on a torus. The first return map of a segment to itself is an interval exchange transformation of three subintervals unless the endpoints of the interval accidentally belong to the same trajectory, in which case we get an interval exchange transformation of two subintervals.

Count of square-tiled tori with two marked points

Let us count the number of square-tiled tori with two labeled marked points located at a pair of corners of the squares assuming that the tori are tiled by at most $N \gg 1$ squares. Cutting our flat torus by a vertical waist curve we get a cylinder with a waist curve of length $w \in \mathbb{N}$ and a distance between boundaries $h \in \mathbb{N}$. The number of squares in the tiling equals $w \cdot h$.

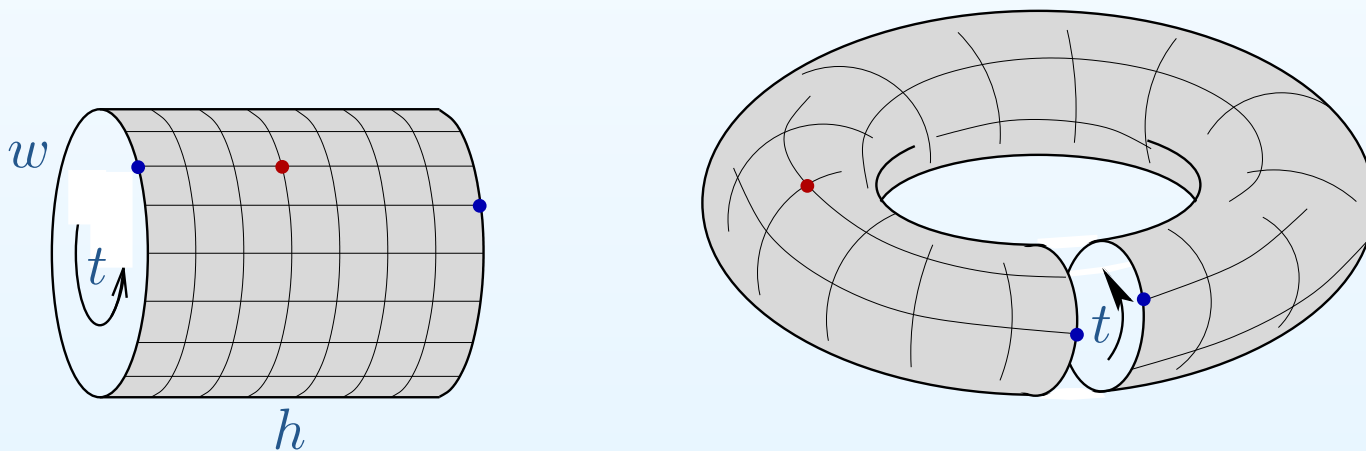

Count of square-tiled tori with two marked points

We can glue a torus from a cylinder with some integer twist t . Making an appropriate Dehn twist along the waist curve we can reduce the value of the twist t to one of the values $0, 1, \dots, w - 1$. Fixing the integer perimeter w and height h of a cylinder we get w square-tiled tori. There are $(w \cdot h - 1)$ ways to place two labeled marked points at a pair of distinct corners of squares.

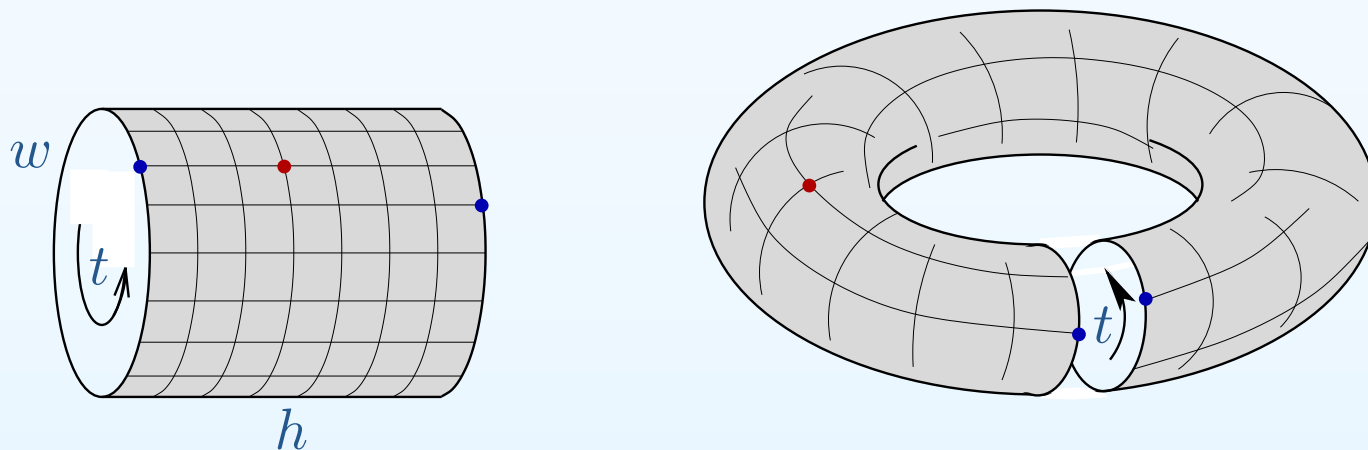

Number of such tori tiled with at most N squares = $\sum_{\substack{w, h \in \mathbb{N} \\ w \cdot h \leq N}} w(w \cdot h - 1) \approx$

$$\sum_{h \in \mathbb{N}} \sum_{\substack{w \in \mathbb{N} \\ w \leq \frac{N}{h}}} w^2 h \approx \sum_{h \in \mathbb{N}} \frac{1}{3} \cdot \left(\frac{N}{h} \right)^3 \cdot h = \frac{N^3}{3} \sum_{h \in \mathbb{N}} \frac{1}{h^2} = \frac{N^3}{3} \cdot \zeta(2) = \frac{N^3}{3} \cdot \frac{\pi^2}{6}.$$

Count when the two marked points are at the same leaf

We can perform a similar count in the case when both marked points belong to the same vertical leaf and when the number h of circular vertical bands of squares is fixed. Now, in addition to the choice of the twist parameter $t \in \{0, 1, \dots, w - 1\}$ there are $(w - 1)$ ways to place two labeled marked points at the vertical leaf of length w .

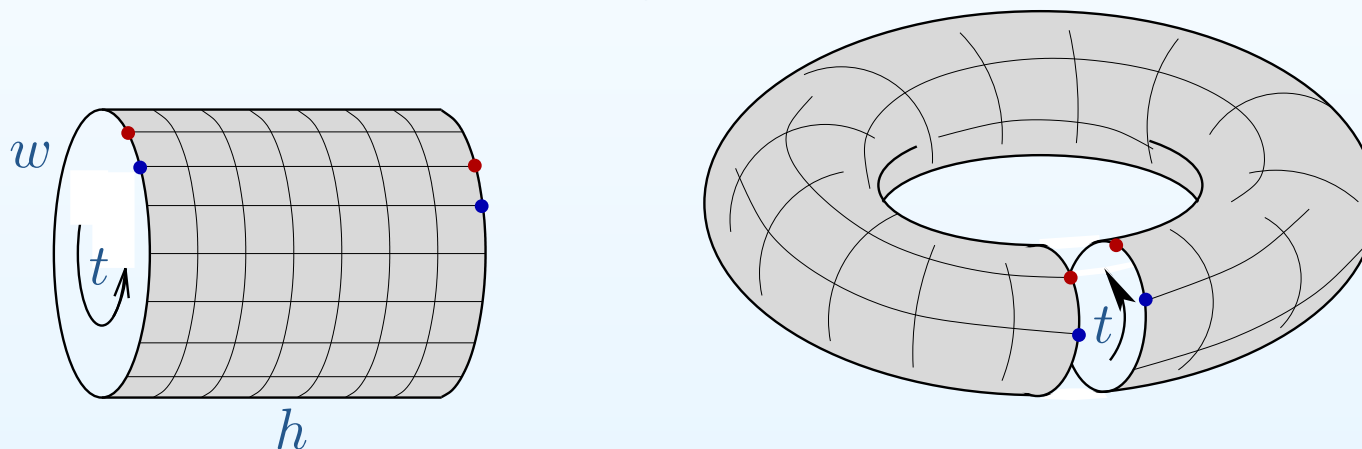

The count of the number of tori as above tiled with at most N squares gives

$$\sum_{\substack{w \in \mathbb{N} \\ w \cdot h \leq N}} w(w - 1) \approx \sum_{\substack{w \in \mathbb{N} \\ w \leq \frac{N}{h}}} w^2 \approx \frac{1}{3} \cdot \left(\frac{N}{h} \right)^3 = \frac{N^3}{3} \cdot \frac{1}{h^3}.$$

Asymptotic proportions

Unexpectedly, the restricted count gives the same order of magnitude N^3 .

We conclude that the proportion $p_{1;h}(N)$ of square-tiled tori tiled with at most N squares satisfying the extra conditions:

- they have exactly h vertical circular bands;
- they have both marked points on the same vertical leaf

satisfies
$$\lim_{N \rightarrow \infty} p_{1;k}(N) = \frac{1}{h^3} \frac{1}{\zeta(2)} = \frac{1}{h^3} \frac{6}{\pi^2}.$$

In particular,

$$\lim_{N \rightarrow \infty} p_{1;1}(N) = \frac{6}{\pi^2}.$$

Denote by $p_{tr}(N)$ the proportion of transitive permutations among all (C, B, A) -permutations of at most N elements.

Theorem (I. Pak, A. Redlich, 2008)

$$\lim_{n \rightarrow +\infty} p_{tr}(N) = \frac{6}{\pi^2}.$$

In the next section we will see that the equality between the two limits is not a coincidence and we will give a complete answer to Arnold's problem.

Arnold's problem

Approach to Arnold's
problem

- Canonical suspension over an interval exchange
- Bands of periodic trajectories
- Why “bands of cycles” and not just cycles?
- Enhanced solution of Arnold's problem

Explicit answers for low dimensional strata

Stratification of the moduli space of holomorphic 1-forms

Approach to Arnold's problem

Canonical suspension over an interval exchange

Consider an interval exchange transformation (iet) $T = (\pi, \lambda)$ of n subintervals, where T chops the interval $[0, \lambda_1 + \cdots + \lambda_n[$ into n consecutive subintervals of lengths $\lambda_1, \dots, \lambda_n$ and places them on X preserving the orientation in the order $\pi^{-1}(1), \dots, \pi^{-1}(n)$ without gaps or overlaps.

We always assume that T does not send consecutive intervals to consecutive intervals, that is $\pi(j+1) \neq \pi(j) + 1$ for $j = 1, \dots, n-1$. (This condition is slightly weaker than the standard *nondegeneracy* condition of an iet). We also assume that π does not have nontrivial invariant subsets of the form $\{1, \dots, k\}$ (otherwise T acts independently on two disjoint intervals).

Canonical suspension over an interval exchange

Consider a broken line in the plane formed from vectors $\vec{V}_j = (\lambda_j, \pi(j) - j)$ and another broken line starting from the same point and composed from the same vectors now placed in the order $\pi^{-1}(1), \dots, \pi^{-1}(n)$ (as subintervals under exchange). Identifying the corresponding pairs of sides of the resulting polygon by parallel translations, we get a flat surface. The vertical flow on this surface realizes a suspension flow over the initial interval exchange. By convention, we mark the two points of the surface coming from the two vertices of the polygon corresponding to the endpoints of the broken lines.

Example of suspension

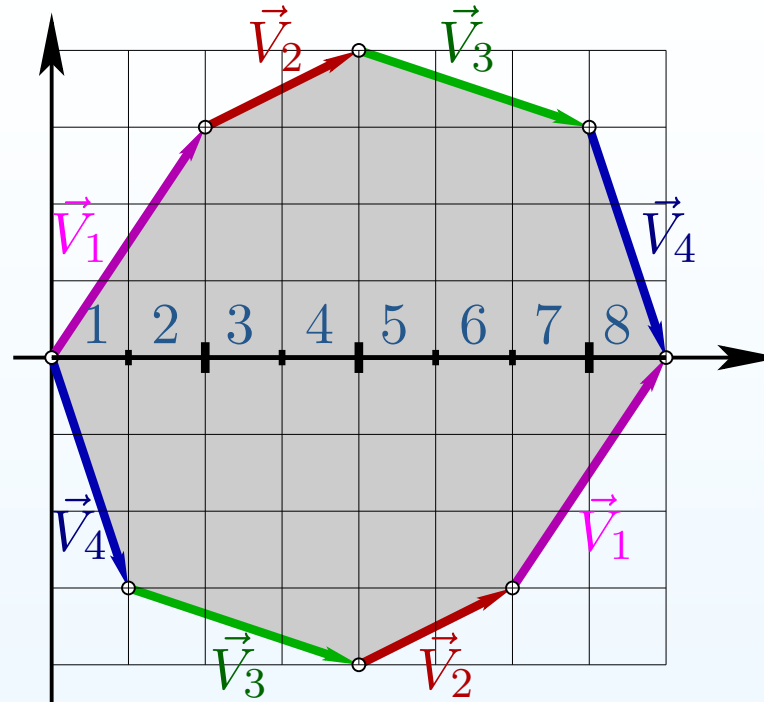

Suspension over an interval exchange transformation $T(\pi, \lambda)$ with parameters

$$\pi^{-1} = \begin{pmatrix} 1 & 2 & 3 & 4 \\ 4 & 3 & 2 & 1 \end{pmatrix} \quad \lambda = (2, 2, 3, 1).$$

The associated *interval exchange permutation* has the form

$$\tau^{-1} = \begin{pmatrix} 1 & 2 & 3 & 4 & 5 & 6 & 7 & 8 \\ 8 & 5 & 6 & 7 & 3 & 4 & 1 & 2 \end{pmatrix}.$$

Vectors $\vec{V}_j = (\lambda_j, \pi(j) - j)$ of the canonical suspension have coordinates

$$\vec{V}_1 = (2, 3) \quad \vec{V}_2 = (2, 1) \quad \vec{V}_3 = (3, -1) \quad \vec{V}_4 = (1, -3).$$

Bands of periodic trajectories

Definition. We say that cycles C_1 and C_2 of a permutation τ belong to the same *band*, if one can choose $k_1 \in C_1$ and $k_2 \in C_2$ such that

$$\tau^{(j)}(k_2) = \tau^{(j)}(k_1) + 1 \quad \text{or} \quad \tau^{(j)}(k_2) = \tau^{(j)}(k_1) - 1 \quad \text{for all } j \in \mathbb{Z}$$

and we consider the minimal equivalence relation induced by this property.

The permutation $(1, 10, 4, 7)(2, 11, 5, 8)(3, 6, 9)$ has two bands of cycles, where the cycles $(1, 10, 4, 7)$ and $(2, 11, 5, 8)$ belong to the same band. The permutation $(1, 9, 3, 5, 7)(2, 10, 4, 6, 8)$ has a single band of cycles.

We have seen that a (C, B, A) -permutation has a single band of cycles if and only if it is “cyclic” in the sense of Arnold; it has two bands of cycles otherwise.

Important Observation. Consider a permutation τ associated to an integer interval exchange transformation (π, λ) , where $\lambda \in \mathbb{N}^n$. The number of bands of cycles of τ coincides with the number of maximal cylinders of the vertical suspension flow on the associated flat surface. (By convention, we mark the points on the surface (possibly a single point) corresponding to the endpoints of the interval if they are nonsingular points of the flat metric.)

Why “bands of cycles” and not just cycles?

Fix a permutation π and consider statistics of the number of cycles of a random *interval exchange permutation* $\tau(\lambda, \pi)$ associated to an integer interval exchange transformation $T(\lambda, \pi)$ of the interval $[0, N[$ as $N \rightarrow \infty$. By “integer” interval exchange we call one with $\lambda \in \mathbb{N}^d$, where $d = \text{Card}(\pi)$.

Theorem (V. Delecroix, E. Goujard, P. Zograf, A. Zorich, 2022). *For any permutation π the mean value of the number of cycles of a random interval exchange permutation $\tau(\lambda, \pi)$ is infinite.*

For any stratum of Abelian differentials, the mean value of the number of vertical (horizontal) bands of squares of a random square-tiled surface in this stratum is infinite.

Remark. Note that for numerous separatrix diagrams, the corresponding mean value for square-tiled surfaces representing these particular diagrams is finite!

The above Theorem explains why an adequate interpretation of Arnold’s problem (the most general question about Young diagrams) suggests to consider *bands of cycles* and not cycles themselves.

Enhanced solution of Arnold's problem

Let π be a non degenerate irreducible permutation. Let $\mathcal{H}^{comp}(m_1, \dots, m_n)$ be a connected component of a stratum of Abelian differentials ambient for the canonical suspension over an interval exchange with a permutation π .

Let $d = \text{Card } \pi$ be the number of elements in π .

Let $\text{Vol } \mathcal{H}^{comp}(m_1, \dots, m_n)$ and $\text{Vol}_k \mathcal{H}^{comp}(m_1, \dots, m_n)$ be respectively the Masur–Veech volume of the component and the contribution of k -cylinder square-tiled surfaces to this volume.

Let U be an open bounded set in \mathbb{R}_+^d . Denote by tU the set obtained from U by dilation with coefficient $t \in \mathbb{R}$. Denote by $IET(\pi, U, \varepsilon)$ and by $IET_k(\pi, U, \varepsilon)$ respectively the number of (π, λ) -integral interval exchange transformations such that $\lambda \in \mathbb{N}^d \cap \frac{1}{\varepsilon}U$ and the number of those of them, which have exactly k bands of periodic vertical trajectories.

Theorem (V. Delecroix, E. Goujard, P. Zograf, A. Zorich, 2020) For any π, U, k as above one has

$$\lim_{\varepsilon \rightarrow +0} \frac{IET_k(\pi, U, \varepsilon)}{IET(\pi, U, \varepsilon)} = \frac{\text{Vol}_k \mathcal{H}^{comp}(m_1, \dots, m_n)}{\text{Vol } \mathcal{H}^{comp}(m_1, \dots, m_n)}.$$

Arnold's problem

Approach to Arnold's problem

Explicit answers for low dimensional strata

- Volume computation for $\mathcal{H}(2)$
- Answer for $(DCBA)$ -permutations
- Multiple zeta-values
- Contribution of k -cylinder surfaces
- After simplification
- Conjecture on Delecroix sums

Stratification of the moduli space of holomorphic 1-forms

Explicit answers for low dimensional strata

Volume computation for $\mathcal{H}(2)$

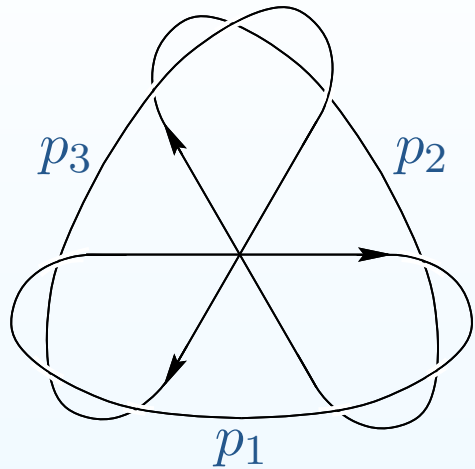

$$\frac{1}{3} \sum_{\substack{p_1, p_2, p_3, h \in \mathbb{N} \\ (p_1 + p_2 + p_3)h \leq N}} (p_1 + p_2 + p_3) \approx \frac{N^4}{24} \cdot \zeta(4)$$

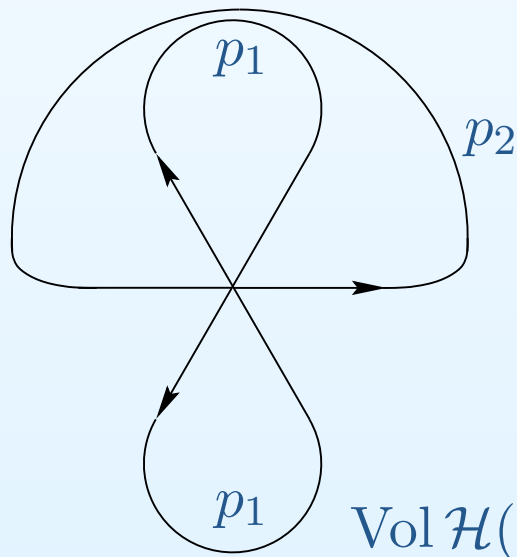

$$\sum_{\substack{p_1, p_2, h_1, h_2 \\ p_1 h_1 + (p_1 + p_2) h_2 \leq N}} p_1 (p_1 + p_2)$$

$$= \frac{N^4}{24} [2 \cdot \zeta(1, 3) + \zeta(2, 2)] = \frac{N^4}{24} \cdot \frac{5}{4} \cdot \zeta(4)$$

$$\text{Vol } \mathcal{H}(2) = \lim_{N \rightarrow \infty} \frac{2 \cdot 4}{N^4} \cdot (\text{Number of all surfaces}) = \frac{3}{4} \zeta(4) = \frac{\pi^4}{120}$$

Answer to Arnold's problem for permutations of 4 elements

- The asymptotic proportion of *transitive* permutations among all

(4, 3, 2, 1)-permutations equals $\frac{4}{9\zeta(4)} = \frac{40}{\pi^4}$.

- The asymptotic proportion of “cyclic” permutations (in Arnold's sense, i.e. of 1-band permutations in our terminology) among all (4, 3, 2, 1)-permutations equals $\frac{4}{9}$.

- The proportion of 2-band permutations is $\frac{5}{9}$. The larger number of bands is not realizable for (4, 3, 2, 1)-permutations.

- Permutations (2, 4, 1, 3), (2, 4, 3, 1), (3, 1, 4, 2), (3, 2, 4, 1), (4, 1, 3, 2), (4, 2, 1, 3), (4, 3, 2, 1) in the Rauzy class of $\mathcal{H}(2)$ share the same proportions.

- All the remaining permutations of 4 elements are either degenerate or reducible.

- A random square-tiled surface in the stratum $\mathcal{H}(2)$ has a single maximal vertical cylinder with probability $\frac{4}{9}$ and two maximal cylinders with probability $\frac{5}{9}$.

Multiple zeta-values

Define

$$\zeta(s_1, s_2, \dots, s_k) = \sum_{n_1, \dots, n_k \geq 1} \frac{1}{n_1^{s_1} (n_1 + n_2)^{s_2} \dots (n_1 + \dots + n_k)^{s_k}}.$$

Multiple zeta-values (MZV) are values of $\zeta(s_1, s_2, \dots, s_k)$ at positive integers $s_j \in \mathbb{N}$, where $s_k \geq 2$. For example

$$\zeta(2) = \frac{\pi^2}{6}; \quad \zeta(4) = \frac{\pi^4}{90}; \quad \dots \quad \zeta(2n) = \frac{p}{q} \pi^{2n}, \quad \text{where } p, q \in \mathbb{N}.$$

Conjecturally $\pi, \zeta(3), \zeta(5), \dots$ are algebraically independent over \mathbb{Q} .

Multiple zeta values satisfy numerous relations. The ones, which we used, namely

$$\zeta(1, 3) = \frac{1}{4} \zeta(4); \quad \zeta(2, 2) = \frac{3}{4} \zeta(4) \quad ,$$

were already known to L. Euler.

Contributions $\text{Vol}_k \mathcal{H}(3, 1)$ of k -cylinder surfaces to $\text{Vol} \mathcal{H}(3, 1)$

$$\text{Vol}_1 \mathcal{H}(3, 1) = \frac{\zeta(7)}{15}$$

$$\text{Vol}_2 \mathcal{H}(3, 1) = \frac{55 \zeta(1, 6) + 29 \zeta(2, 5) + 15 \zeta(3, 4) + 8 \zeta(4, 3) + 4 \zeta(5, 2)}{45}$$

$$\begin{aligned} \text{Vol}_3 \mathcal{H}(3, 1) = & \frac{1}{90} \left(12 \zeta(6) - 12 \zeta(7) + 48 \zeta(4) \zeta(1, 2) + 48 \zeta(3) \zeta(1, 3) \right. \\ & + 24 \zeta(2) \zeta(1, 4) + 6 \zeta(1, 5) - 250 \zeta(1, 6) - 6 \zeta(3) \zeta(2, 2) \\ & - 5 \zeta(2) \zeta(2, 3) + 6 \zeta(2, 4) - 52 \zeta(2, 5) + 6 \zeta(3, 3) - 82 \zeta(3, 4) \\ & + 6 \zeta(4, 2) - 54 \zeta(4, 3) + 6 \zeta(5, 2) + 120 \zeta(1, 1, 5) - 30 \zeta(1, 2, 4) \\ & - 120 \zeta(1, 3, 3) - 120 \zeta(1, 4, 2) - 54 \zeta(2, 1, 4) - 34 \zeta(2, 2, 3) \\ & \left. - 29 \zeta(2, 3, 2) - 88 \zeta(3, 1, 3) - 34 \zeta(3, 2, 2) - 48 \zeta(4, 1, 2) \right) \end{aligned}$$

$$\text{Vol}_4 \mathcal{H}(3, 1) = \frac{2\zeta(2)}{45} \left(\zeta(4) - \zeta(5) + \zeta(1, 3) + \zeta(2, 2) - \zeta(2, 3) - \zeta(3, 2) \right).$$

After simplification

Multiple zeta values satisfy numerous relations. After simplification (which is now accessible through a SAGE package) we get

$$\text{Vol}_1 \mathcal{H}(3, 1) = 1/15 \cdot \zeta(7)$$

$$\text{Vol}_2 \mathcal{H}(3, 1) = -7/135 \cdot \zeta(1, 6) + 1/135 \cdot \zeta(2, 5) + 23/135 \cdot \zeta(7)$$

$$\text{Vol}_3 \mathcal{H}(3, 1) = -2/15 \cdot \zeta(1, 6) - 2/45 \cdot \zeta(2, 5) + 1/5 \cdot \zeta(6) - 4/45 \cdot \zeta(7)$$

$$\text{Vol}_4(\mathcal{H}(3, 1) = 5/27 \cdot \zeta(1, 6) + 1/27 \cdot \zeta(2, 5) + 7/45 \cdot \zeta(6) - 4/27 \cdot \zeta(7)$$

Conjecturally, multiple zeta values involved in these simplified expressions are linearly independent over rational numbers. However, the total contribution is a rational multiple of π^{2g} in accordance with the general result by A. Eskin and A. Okounkov, 2001:

$$\text{Vol } \mathcal{H}(3, 1) = \text{Vol}_1 \mathcal{H}(3, 1) + \cdots + \text{Vol}_4 \mathcal{H}(3, 1) = \frac{16}{45} \zeta(6) = \frac{16}{42525} \pi^6$$

Conjecture on Delecroix sums

Conjecture (V. Delecroix, A. Zorich). *For any connected component of any stratum $\mathcal{H}(m_1, \dots, m_n)$ of Abelian differentials and for any positive integer k , the contribution $\text{Vol}_k \mathcal{H}^{\text{comp}}(m_1, \dots, m_n)$ of k -cylinder square-tiled surfaces to the Masur-Veech volume of the component of the stratum is a linear combination of multiple zeta values with rational coefficients.*

For $k = 1$ this fact is elementary; for $k = 2$ it is relatively easy to prove; for $k = 3$ it is already a nontrivial theorem due to B. Allombert and V. Delecroix. These three rigorous results valid for all strata combined with further direct computations in small genera strongly corroborate to the conjecture.

This (conjectural) form of contribution of k -cylinder square-tiled surfaces indicates that they might have geometric meaning which we do not understand yet. It is a great challenge to interpret these contributions as certain periods and relate them to cycles in the moduli space. The arithmetic properties of the “Delecroix sums” which appear as contributions of individual separatrix diagrams to the Masur-Veech volumes are interesting by themselves.

$$\begin{aligned}
\text{Vol}_5(\mathcal{H}(2, 1, 1)) = & \frac{1}{1260} \cdot \left(10\zeta(2)\zeta(4) - 30\zeta(2)\zeta(5) + 77\zeta(6) + 20\zeta(2)\zeta(6) - 231\zeta(7) \right. \\
& + 154\zeta(8) + 40\zeta(3)\zeta(1, 2) + 64\zeta(2)\zeta(1, 3) + 32\zeta(3)\zeta(1, 3) \\
& - 24\zeta(4)\zeta(1, 3) + 138\zeta(2)\zeta(1, 4) - 96\zeta(3)\zeta(1, 4) - 326\zeta(1, 5) \\
& - 240\zeta(2)\zeta(1, 5) - 1650\zeta(1, 6) + 2736\zeta(1, 7) + 17\zeta(2)\zeta(2, 2) \\
& \quad + 32\zeta(3)\zeta(2, 2) - 12\zeta(4)\zeta(2, 2) + 27\zeta(2)\zeta(2, 3) \\
& \quad - 56\zeta(3)\zeta(2, 3) + 26\zeta(2, 4) - 54\zeta(2)\zeta(2, 4) - 805\zeta(2, 5) \\
& + 1146\zeta(2, 6) - 14\zeta(2)\zeta(3, 2) - 12\zeta(3)\zeta(3, 2) + 54\zeta(3, 3) \\
& \quad + 16\zeta(2)\zeta(3, 3) - 407\zeta(3, 4) + 524\zeta(3, 5) + 96\zeta(4, 2) \\
& \quad + 12\zeta(2)\zeta(4, 2) - 268\zeta(4, 3) + 234\zeta(4, 4) - 272\zeta(5, 2) \\
& \quad + 176\zeta(5, 3) + 160\zeta(6, 2) + 108\zeta(1, 1, 4) - 468\zeta(1, 1, 5) \\
& + 240\zeta(1, 1, 6) - 22\zeta(1, 2, 3) - 558\zeta(1, 2, 4) + 576\zeta(1, 2, 5) \\
& - 42\zeta(1, 3, 2) - 304\zeta(1, 3, 3) + 336\zeta(1, 3, 4) - 258\zeta(1, 4, 2) \\
& \quad + 264\zeta(1, 4, 3) + 336\zeta(1, 5, 2) + 6\zeta(2, 1, 3) - 282\zeta(2, 1, 4) \\
& + 336\zeta(2, 1, 5) + 27\zeta(2, 2, 2) - 454\zeta(2, 2, 3) + 432\zeta(2, 2, 4) \\
& - 365\zeta(2, 3, 2) + 400\zeta(2, 3, 3) + 330\zeta(2, 4, 2) - 40\zeta(3, 1, 2) \\
& - 116\zeta(3, 1, 3) + 120\zeta(3, 1, 4) - 240\zeta(3, 2, 2) + 244\zeta(3, 2, 3) \\
& \quad \left. + 192\zeta(3, 3, 2) + 48\zeta(4, 1, 3) + 108\zeta(4, 2, 2) \right)
\end{aligned}$$

After simplification

After simplification (which is now accessible through a SAGE package) we get

$$\text{Vol}_1 \mathcal{H}(2, 1, 1) = 7/180 \cdot \zeta(8)$$

$$\text{Vol}_2 \mathcal{H}(2, 1, 1) = -2/63 \cdot \zeta(1, 7) + 1/63 \cdot \zeta(2, 6) + 1/36 \cdot \zeta(7) + 59/756 \cdot \zeta(8)$$

$$\begin{aligned} \text{Vol}_3 \mathcal{H}(2, 1, 1) &= 8/63 \cdot \zeta(1, 1, 6) - 1/378 \cdot \zeta(1, 6) - 26/63 \cdot \zeta(1, 7) \\ &+ 61/3780 \cdot \zeta(2, 5) - 4/63 \cdot \zeta(2, 6) + 953/3780 \cdot \zeta(7) - 1213/7560 \cdot \zeta(8) \end{aligned}$$

$$\begin{aligned} \text{Vol}_4 \mathcal{H}(2, 1, 1) &= -16/63 \cdot \zeta(1, 1, 6) - 365/756 \cdot \zeta(1, 6) + 58/63 \cdot \zeta(1, 7) \\ &- 187/1890 \cdot \zeta(2, 5) + 5/63 \cdot \zeta(2, 6) + 1/18 \cdot \zeta(6) + 983/3780 \cdot \zeta(7) - 83/280 \cdot \zeta(8) \end{aligned}$$

$$\begin{aligned} \text{Vol}_5 \mathcal{H}(2, 1, 1) &= 8/63 \cdot \zeta(1, 1, 6) + 367/756 \cdot \zeta(1, 6) - 10/21 \cdot \zeta(1, 7) \\ &+ 313/3780 \cdot \zeta(2, 5) - 2/63 \cdot \zeta(2, 6) + 7/36 \cdot \zeta(6) - 2041/3780 \cdot \zeta(7) + 257/756 \cdot \zeta(8) \end{aligned}$$

$$\text{Vol} \mathcal{H}(2, 1, 1) = 1/4 \cdot \zeta(6)$$

Conjecturally, multiple zeta values involved in these simplified expressions are linearly independent over rational numbers. Once again, the total contribution is a rational multiple of π^{2g} in accordance with the general result by A. Eskin and A. Okounkov, 2001:

$$\text{Vol} \mathcal{H}(2, 1, 1) = \text{Vol}_1 \mathcal{H}(2, 1, 1) + \cdots + \text{Vol}_5 \mathcal{H}(2, 1, 1) = \frac{1}{4} \zeta(6) = \frac{\pi^6}{3780}$$

Arnold's problem

Approach to Arnold's problem

Explicit answers for low dimensional strata

Stratification of the moduli space of holomorphic 1-forms

- Strata
 - Hyperelliptic components
 - Parity of the spin-structure
 - Index of a smooth closed path on a flat surface
 - Parity of the spin structure
 - Classification
- Theorem: genus four and higher
- Classification
- Theorem: low genera
- Components of the minimal stratum in genus three

Stratification of the moduli space of holomorphic 1-forms

Stratification of the moduli space of Abelian differentials

The moduli space of Abelian differentials \mathcal{H}_g is the space of pairs (Riemann surface, holomorphic 1-form on it) considered up to a natural quotient. The moduli space of Abelian differentials \mathcal{H}_g is a total space of a holomorphic vector bundle over the moduli space \mathcal{M}_g of Riemann surfaces with a fiber \mathbb{C}^g .

The space \mathcal{H}_g is stratified by degrees of zeroes of holomorphic one forms. A stratum $\mathcal{H}(m_1, \dots, m_n)$, where $m_1 + \dots + m_n = 2g - 2$, in general does not fiber over \mathcal{M}_g . For example, the dimension of the smallest stratum (of the one, for which all zeroes have merged to a single zero of degree $2g - 2$) is much less than the dimension of \mathcal{M}_g : such a differential cannot be found on a general Riemann surface:

$$2g - 1 = \dim \mathcal{PH}(2g - 2) < \dim \mathcal{M}_g = 3g - 3 \quad \text{for } g > 2.$$

Hyperelliptic components

Connected components of strata provide natural ergodic components of the Teichmüller flow, which explains importance of classification of components for problems of dynamics.

For every hyperelliptic Riemann surface it is easy to construct $2g + 2$ holomorphic 1-forms having a single zero of maximal multiplicity $2g - 2$ at one of the $2g + 2$ Weierstrass points. For each Weierstrass point the corresponding 1-form is defined up to a multiplicative constant. An elementary dimension count shows that the resulting *hyperelliptic locus* in the stratum $\mathcal{H}(2g - 2)$ has the dimension of the stratum, and, hence, forms a connected component of it.

Proof. We first construct a meromorphic quadratic differential q on \mathbb{CP}^1 having a single zero of degree $2g - 3$ and $2g + 1$ simple poles. Location of the zero and of the poles defines q up to a multiplicative constant. We can choose freely a configuration of $2g + 2$ points. A modular transformation sends three points to $0, 1, \infty$, which leaves $2g$ free parameters. The quadratic differential induced on the double cover ramified at all zeroes and poles of q is a square of a globally defined holomorphic 1-form in $\mathcal{H}^{hyp}(2g - 2)$. Thus, $\dim \mathcal{H}^{hyp}(2g - 2) = 2g$. The ambient stratum has the same dimension $\dim \mathcal{H}(2g - 2) = 2g$.

Hyperelliptic components

Connected components of strata provide natural ergodic components of the Teichmüller flow, which explains importance of classification of components for problems of dynamics.

For every hyperelliptic Riemann surface it is easy to construct $2g + 2$ holomorphic 1-forms having a single zero of maximal multiplicity $2g - 2$ at one of the $2g + 2$ Weierstrass points. For each Weierstrass point the corresponding 1-form is defined up to a multiplicative constant. An elementary dimension count shows that the resulting *hyperelliptic locus* in the stratum $\mathcal{H}(2g - 2)$ has the dimension of the stratum, and, hence, forms a connected component of it.

A similar dimension count shows that the hyperelliptic locus has full dimension in exactly one other stratum, namely, in $\mathcal{H}(g - 1, g - 1)$. The two zeroes of any holomorphic differential in the hyperelliptic component $\mathcal{H}^{hyp}(g - 1, g - 1)$ are in involution. The complementary hyperelliptic locus, for which the two zeroes are fixed by the involution, has complex codimension 1.

Parity of the spin-structure

If multiplicities (orders) of all zeroes of a holomorphic 1-form ω are even, ω carries *odd* or *even spin-structure*. It is defined as the parity of the dimension of the linear system corresponding to the divisor $\frac{1}{2}K(\omega)$. Deformations of the pair (Riemann surface, holomorphic 1-form) inside the ambient stratum make change this dimension. However, by independent results of M. Atiyah and D. Mumford, the jumps of dimension are always even. Thus, the parity of the spin-structure depends only on the connected component of the ambient stratum $\mathcal{H}(2k_1, \dots, 2k_n)$.

Merging several zeroes of even degrees of the holomorphic 1-form into a single zero by a continuous deformation we again get a 1-form with zeroes of even degrees. Results of M. Atiyah and D. Mumford imply that it would define the same parity of the spin structure as the original 1-form.

Another way to define the parity of the spin-structure uses the flat metric inherited from the holomorphic 1-form and the induced Gauss map on smooth representatives of a basis of cycles on the Riemann surface.

Index of a smooth closed path on a flat surface

Consider a simple smooth closed path ρ on a flat surface avoiding conical singularities. At any point of the surfaces we know where is the “direction to the North”. Hence, at any point $z = \rho(t)$ we can apply a compass and measure the direction of the tangent vector \dot{z} . Moving along ρ we make the tangent vector turn in the compass.

Index of a smooth closed path on a flat surface

Consider a simple smooth closed path ρ on a flat surface avoiding conical singularities. At any point of the surfaces we know where is the “direction to the North”. Hence, at any point $z = \rho(t)$ we can apply a compass and measure the direction of the tangent vector \dot{z} . Moving along ρ we make the tangent vector turn in the compass.

We get a map $G(\rho) : S^1 \rightarrow S^1$ from the parameterized closed path to the circumference of the compass. This map is called the *Gauss map*.

Index of a smooth closed path on a flat surface

Consider a simple smooth closed path ρ on a flat surface avoiding conical singularities. At any point of the surfaces we know where is the “direction to the North”. Hence, at any point $z = \rho(t)$ we can apply a compass and measure the direction of the tangent vector \dot{z} . Moving along ρ we make the tangent vector turn in the compass.

We get a map $G(\rho) : S^1 \rightarrow S^1$ from the parameterized closed path to the circumference of the compass. This map is called the *Gauss map*.

We define the *index* $ind(\rho)$ of the path ρ as a degree of the corresponding Gauss map (or, in other words as the algebraic number of turns of the tangent vector around the compass) taken modulo 2.

$$ind(\rho) = \deg G(\rho) \pmod{2}$$

Index of a smooth curve

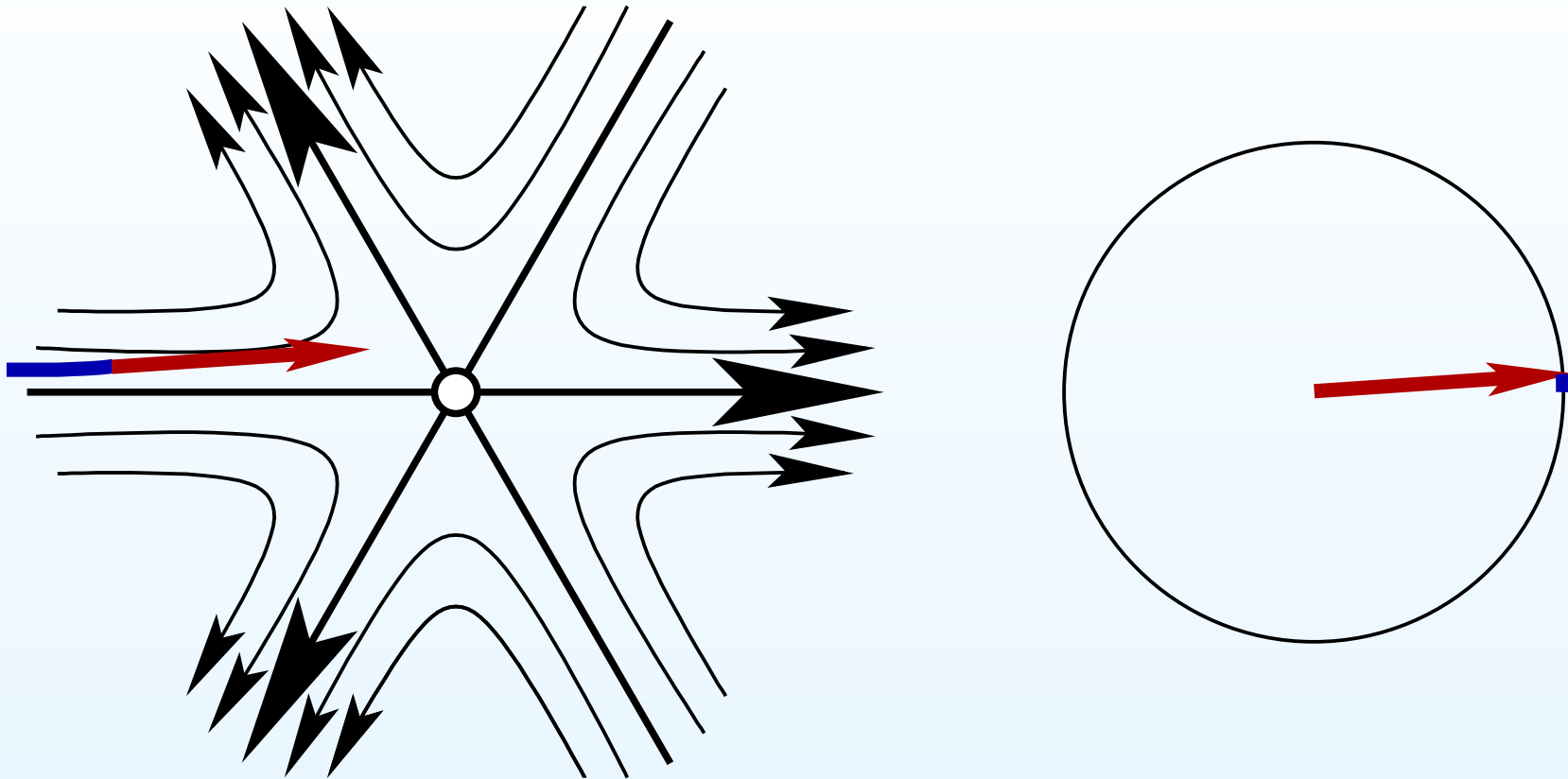

Following the blue path we make its image under the Gauss map perform a complete turn around the unit circle in the counterclockwise direction.

Index of a smooth curve

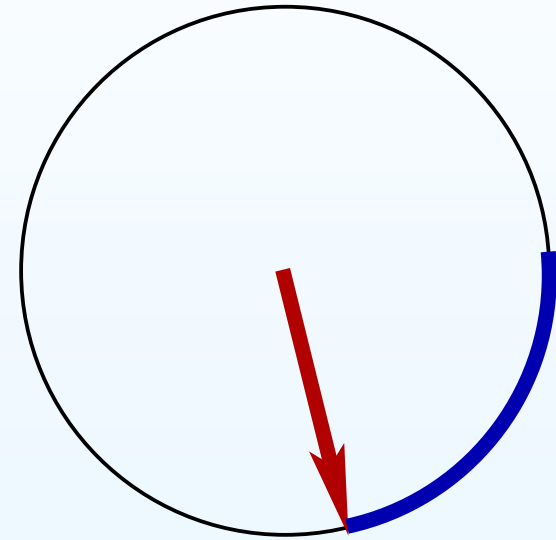
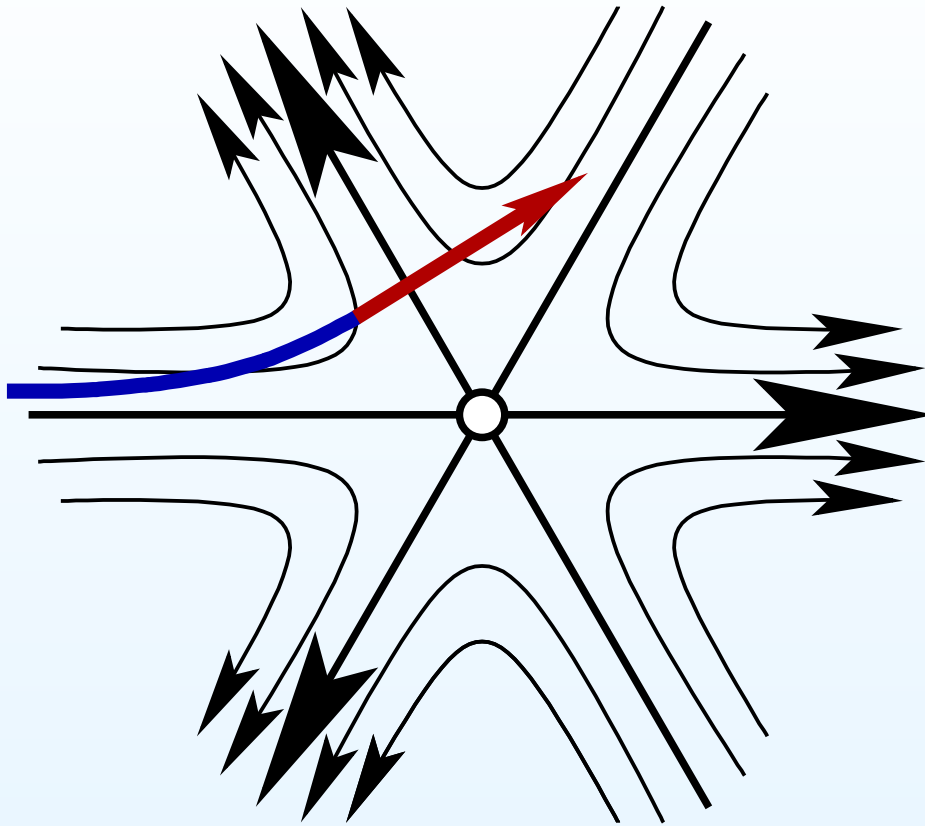

Following the blue path we make its image under the Gauss map perform a complete turn around the unit circle in the counterclockwise direction.

Index of a smooth curve

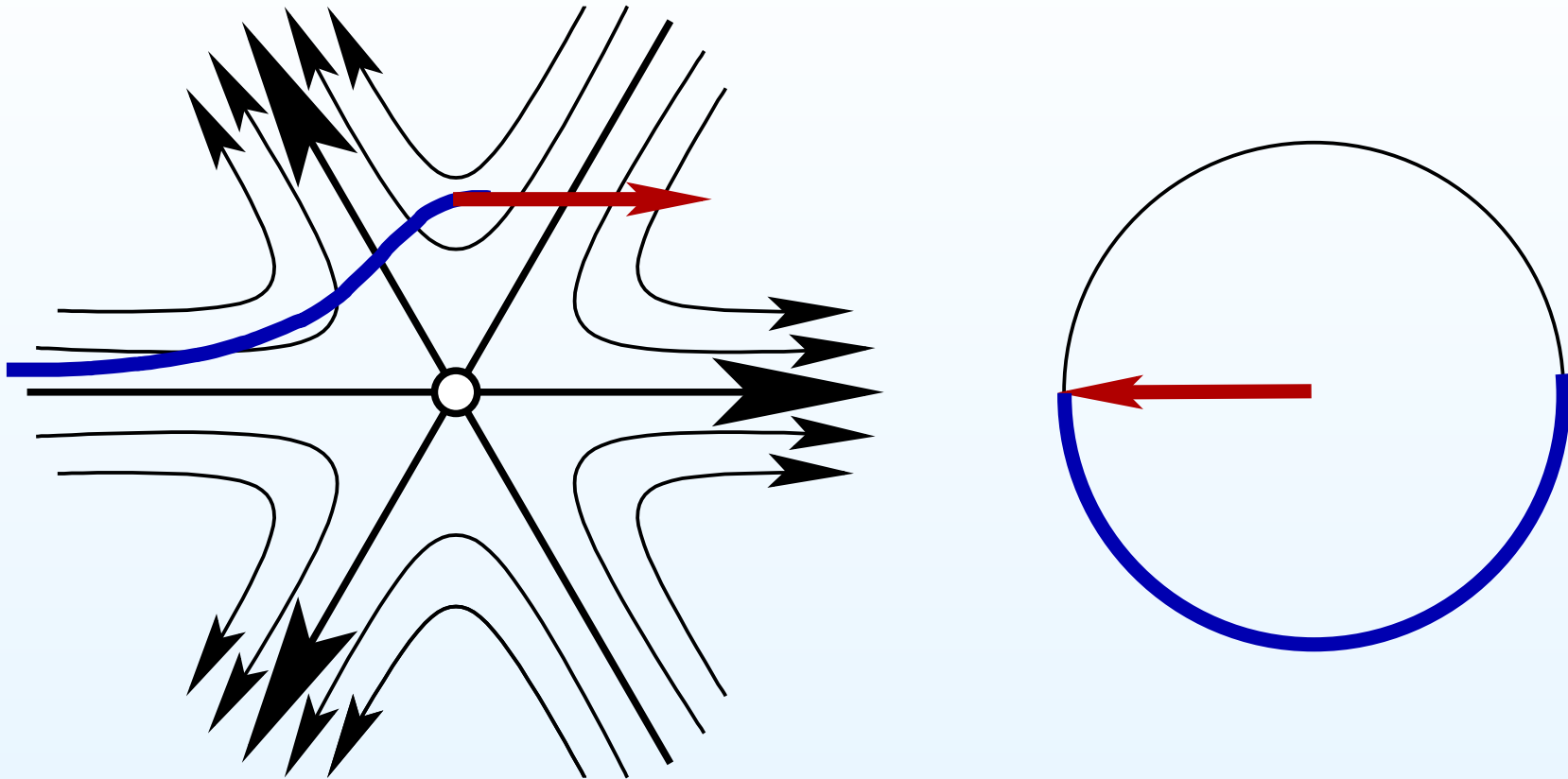

Following the blue path we make its image under the Gauss map perform a complete turn around the unit circle in the counterclockwise direction.

Index of a smooth curve

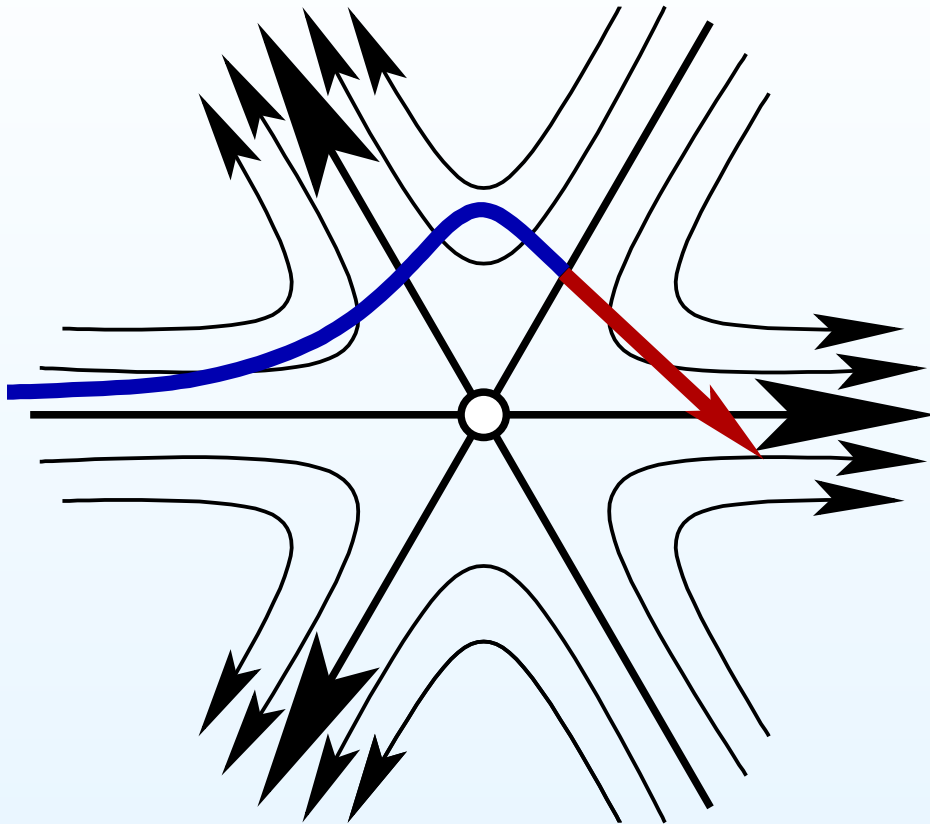

Following the blue path we make its image under the Gauss map perform a complete turn around the unit circle in the counterclockwise direction.

Index of a smooth curve

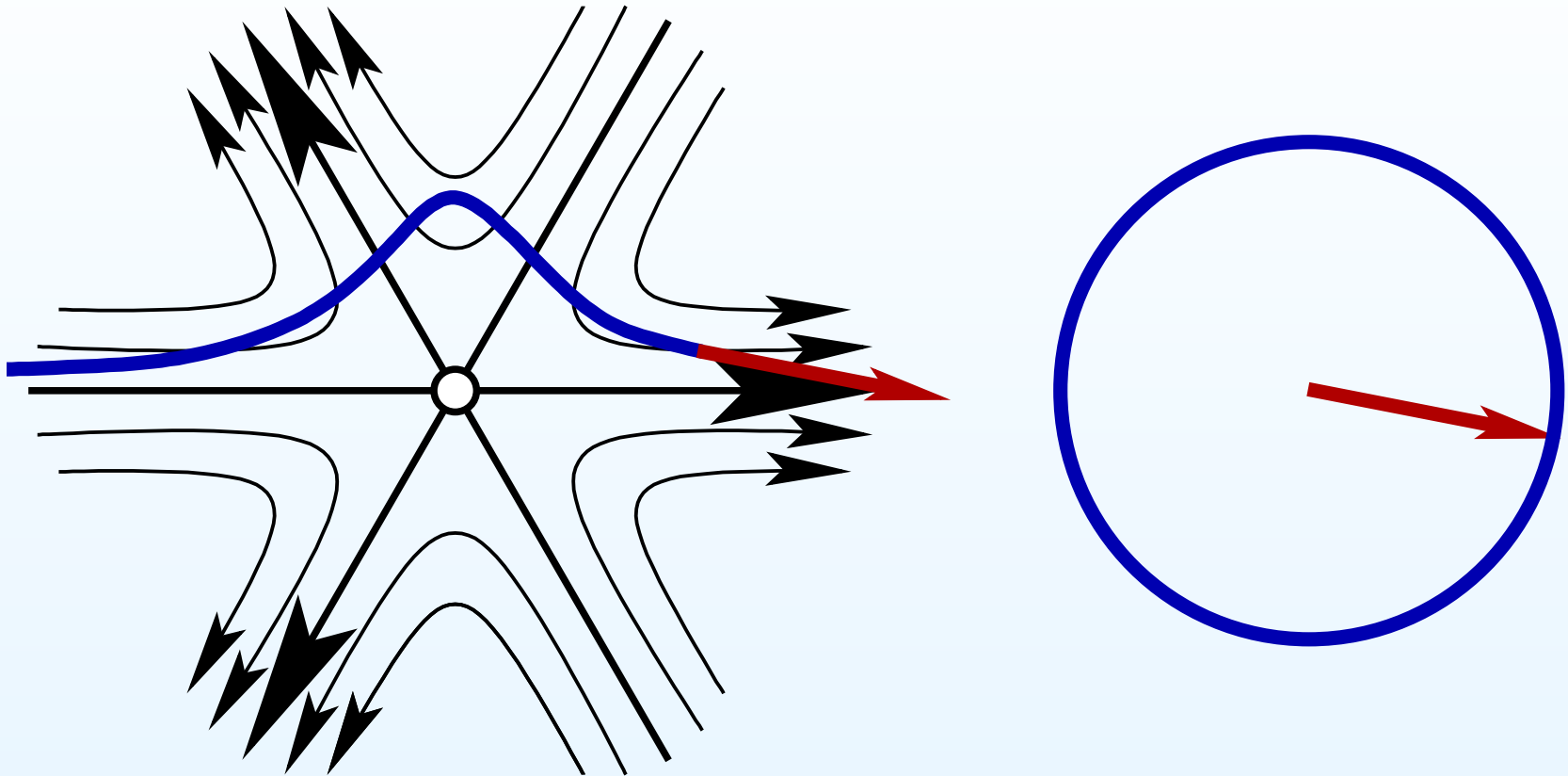

Following the blue path we make its image under the Gauss map perform a complete turn around the unit circle in the counterclockwise direction.

Index of a smooth curve

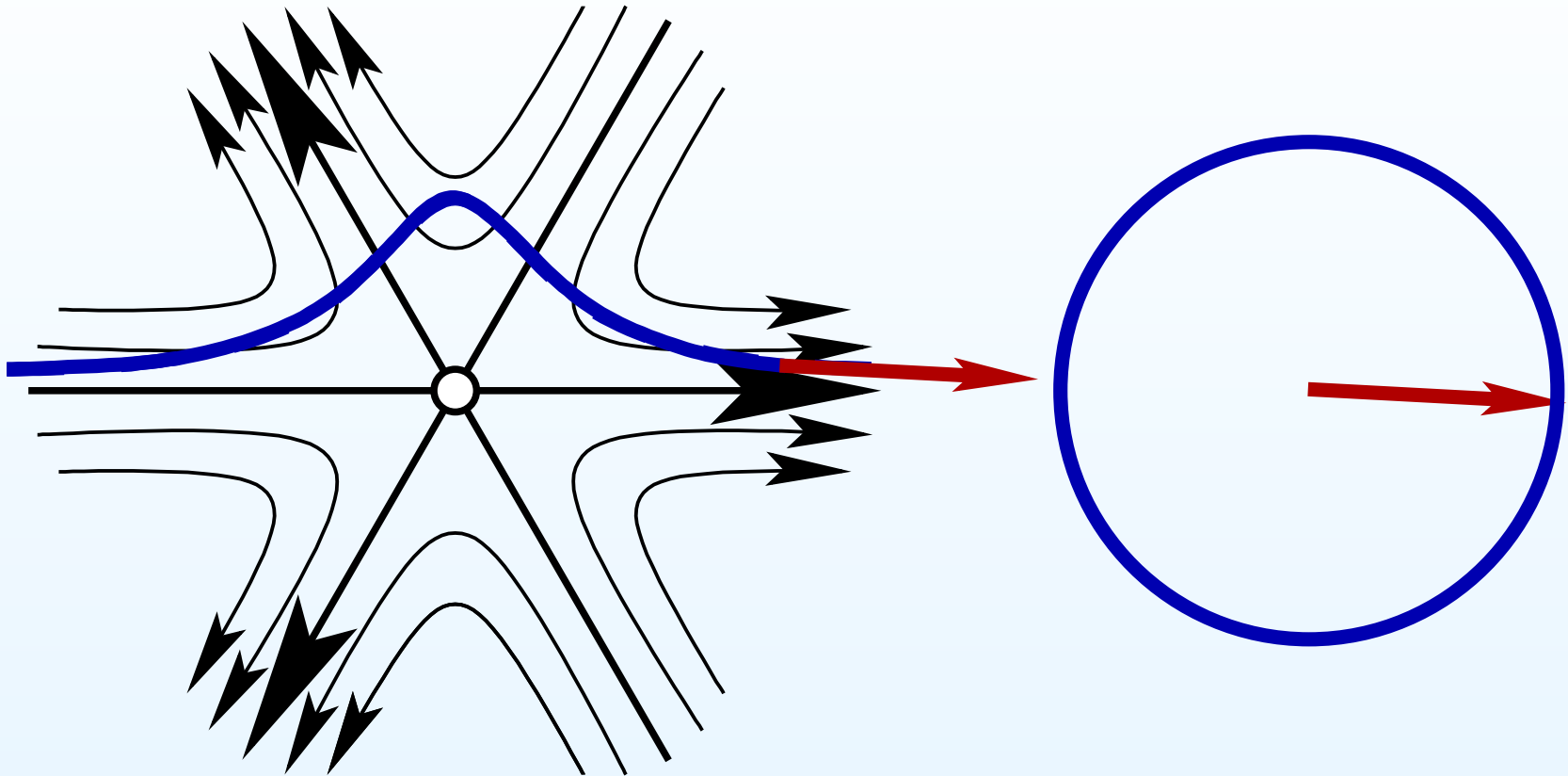

Following the blue path we make its image under the Gauss map perform a complete turn around the unit circle in the counterclockwise direction.

Parity of the spin structure

It is easy to see that $ind(\rho)$ does not depend on parametrization. Moreover, it does not change under small deformations of the path.

Exercise. If a conical point P has a cone angle which is an odd multiple of 2π , then bypassing P on one side or on the other we get the same $ind(\rho)$.

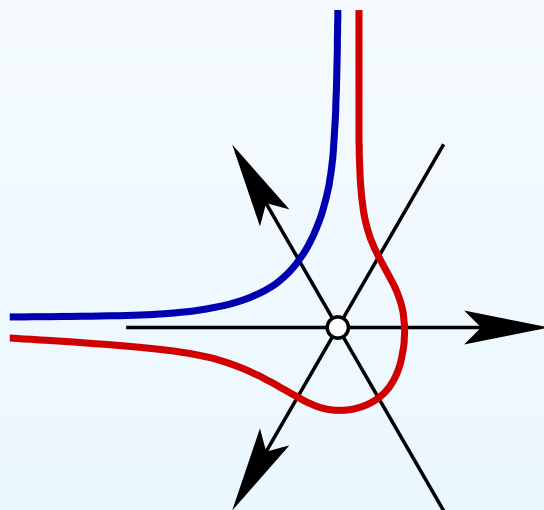

Parity of the spin structure

It is easy to see that $ind(\rho)$ does not depend on parametrization. Moreover, it does not change under small deformations of the path.

Exercise. If a conical point P has a cone angle which is an odd multiple of 2π , then bypassing P on one side or on the other we get the same $ind(\rho)$.

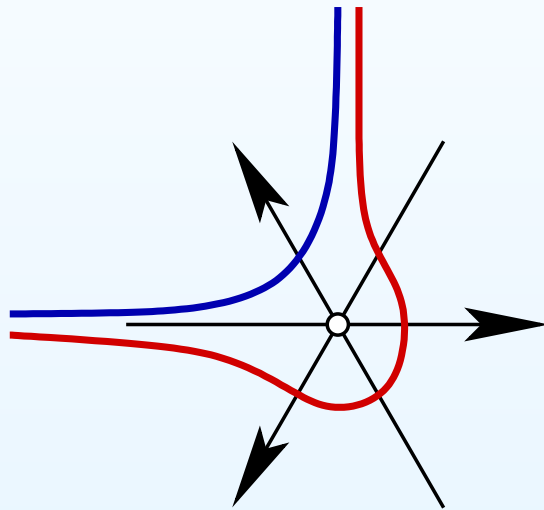

Consider a collection of simple closed smooth paths $a_1, b_1, \dots, a_g, b_g$ representing a symplectic basis of homology $H_1(S, \mathbb{Z}/2\mathbb{Z})$. We define a *parity of the spin-structure* of a flat surface $S \in \mathcal{H}(2d_1, \dots, 2d_n)$ as

$$\phi(S) = \sum_{i=1}^g (ind(a_i) + 1) (ind(b_i) + 1) \pmod{2}$$

Exercise. Compute a parity of the spin structure for a flat torus.

Classification Theorem: genus four and higher

Theorem (M. Kontsevich, A. Zorich) *General case: $g \geq 4$.*

- *The stratum $\mathcal{H}(2g - 2)$ has three connected components: the hyperelliptic one, $\mathcal{H}^{hyp}(2g - 2)$, and two other components: $\mathcal{H}^{even}(2g - 2)$ and $\mathcal{H}^{odd}(2g - 2)$ corresponding to even and odd spin structures.*
- *The stratum $\mathcal{H}(2l, 2l)$, $l \geq 2$ has three connected components: the hyperelliptic one, $\mathcal{H}^{hyp}(2l, 2l)$, and two other components: $\mathcal{H}^{even}(2l, 2l)$ and $\mathcal{H}^{odd}(2l, 2l)$.*
- *All the other strata of the form $\mathcal{H}(2l_1, \dots, 2l_n)$, where all $l_i \geq 1$, have two connected components: $\mathcal{H}^{even}(2l_1, \dots, 2l_n)$ and $\mathcal{H}^{odd}(2l_1, \dots, 2l_n)$, corresponding to even and odd spin structures.*
- *The strata $\mathcal{H}(2l - 1, 2l - 1)$, $l \geq 2$, have two connected components; one of them, $\mathcal{H}^{hyp}(2l - 1, 2l - 1)$, is hyperelliptic; the other one, $\mathcal{H}^{nonhyp}(2l - 1, 2l - 1)$, is not.*
- *All other strata of Abelian differentials on complex curves of genera $g \geq 4$ are nonempty and connected.*

Classification Theorem: low genera

The theorem below shows that in genera $g = 2, 3$ some components are missing with respect to the general case.

Theorem

- *The moduli space of Abelian differentials on a complex curve of genus $g = 2$ contains two strata: $\mathcal{H}(1, 1)$ and $\mathcal{H}(2)$. Each of them is connected and coincides with its hyperelliptic component.*
- *Each of the strata $\mathcal{H}(2, 2)$, $\mathcal{H}(4)$ of the moduli space of Abelian differentials on a complex curve of genus $g = 3$ has two connected components: the hyperelliptic one, and one having odd spin structure. The other strata are connected for genus $g = 3$.*

Components of the minimal stratum in genus three

- Check that the following two flat surfaces belong to the stratum $\mathcal{H}(4)$.

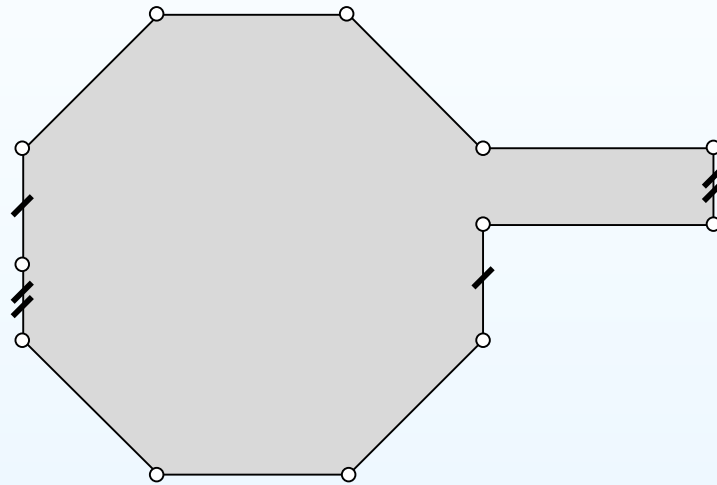
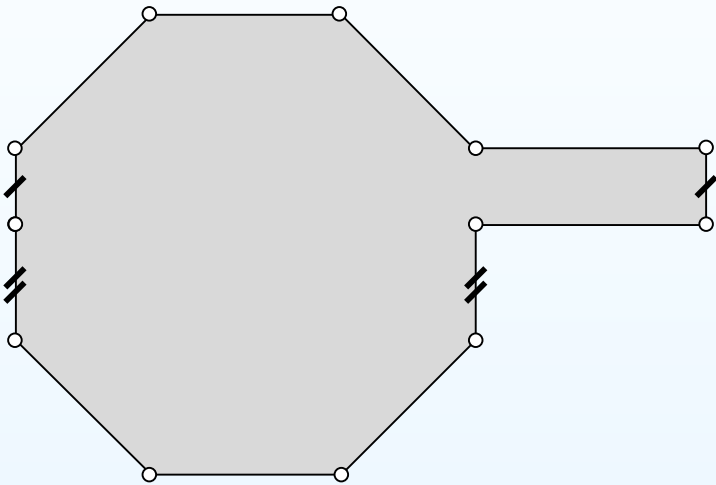

Components of the minimal stratum in genus three

- Check that the following two flat surfaces belong to the stratum $\mathcal{H}(4)$.

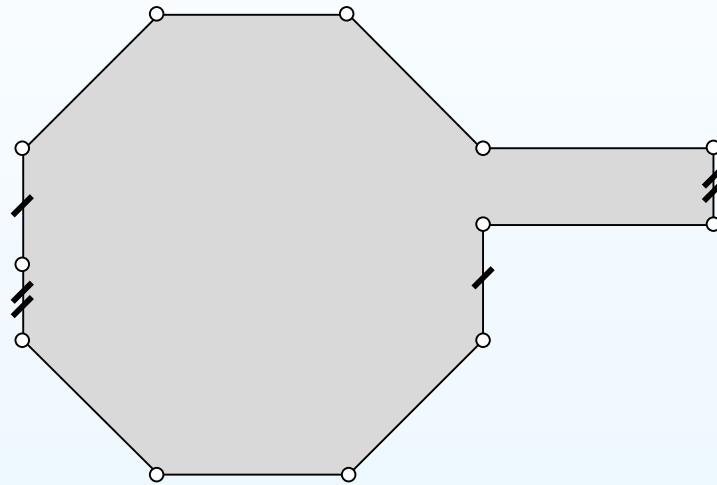
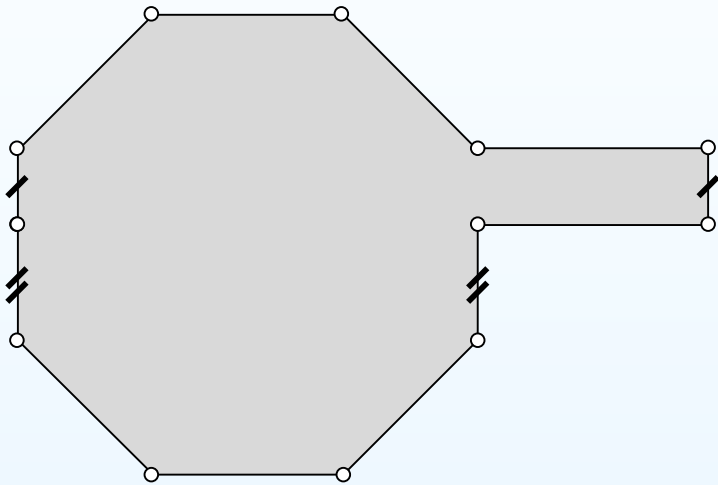

- Compute the parity of the spin structure for these surfaces (and notice that it is not the same).

Components of the minimal stratum in genus three

- Check that the following two flat surfaces belong to the stratum $\mathcal{H}(4)$.

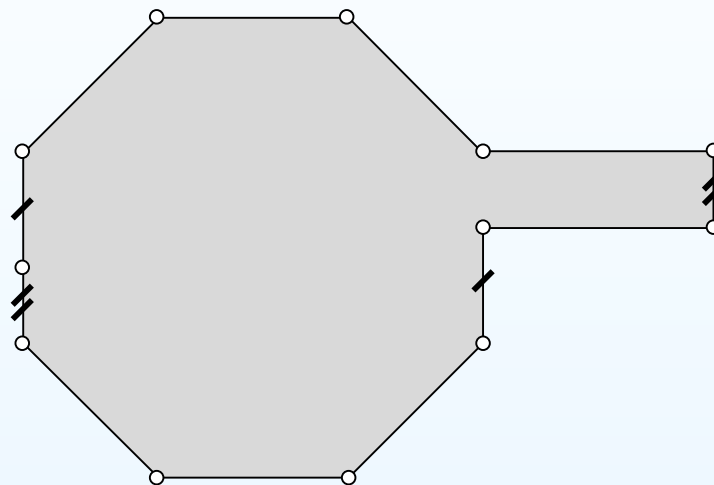
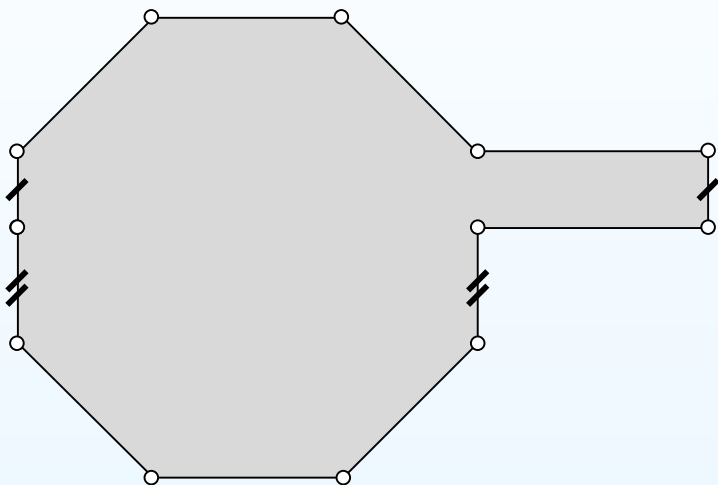

- Compute the parity of the spin structure for these surfaces (and notice that it is not the same).
- Determine which of the two surfaces is hyperelliptic.

Components of the minimal stratum in genus three

- Check that the following two flat surfaces belong to the stratum $\mathcal{H}(4)$.

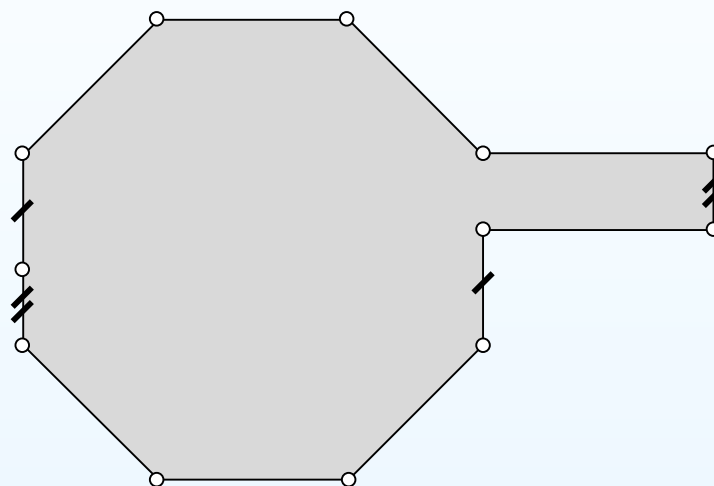
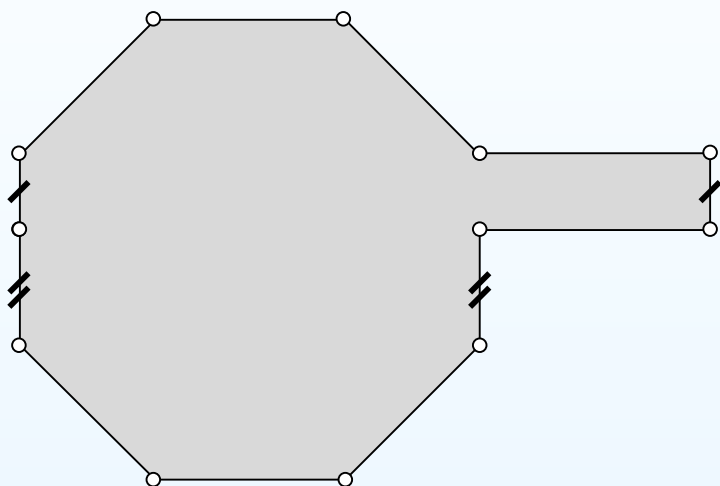

- Compute the parity of the spin structure for these surfaces (and notice that it is not the same).
- Determine which of the two surfaces is hyperelliptic.
- Find the hyperelliptic involution of this surface in geometric terms. Find the Weierstrass points (the fixed points of the hyperelliptic involution). Check that there are $2g + 2$ such points.

Reconstruct a surface from interval exchange transformation

V. Arnold writes in his comment: *“Kontsevich has recently attempted to claim that the interval exchange of three segments is always rotation equivalent. Problem 2002-8 requires the study of the frequency of the counterexamples to this “equivalence” (the existence of such counterexamples being, of course, known to me in the 1950s while I was inventing the segments interchange problem.)”*

Problem.

1. Suppose that a transitive flow on a translation surface S induces an interval exchange transformation with a permutation $(3, 2, 1)$ as the first return map to some transverse interval. What is the genus of S and what is the number and types of conical singularities of the flat metric on S ?
2. Same question for the permutation $(4, 3, 2, 1)$.
3. Suggest a geometric interpretation of the claim of Kontsevich which Arnold did not understand.
4. Suggest a geometric interpretation of the claim by Arnold that an interval exchange transformation with permutation $(2, 1)$ is “rotation equivalent”.