

Geometry and dynamics in moduli spaces

Solutions of some problems from homework assignment 2

Anton Zorich
Université Paris Cité

April 9, 2026

Playing with train tracks

The picture on the left presents the four “basic” train tracks τ_1, \dots, τ_4 on a four-punctured sphere. Find which of these four basic train-tracks (if any) carries the simple closed curve γ on top of the right picture. Indicate the resulting weights.

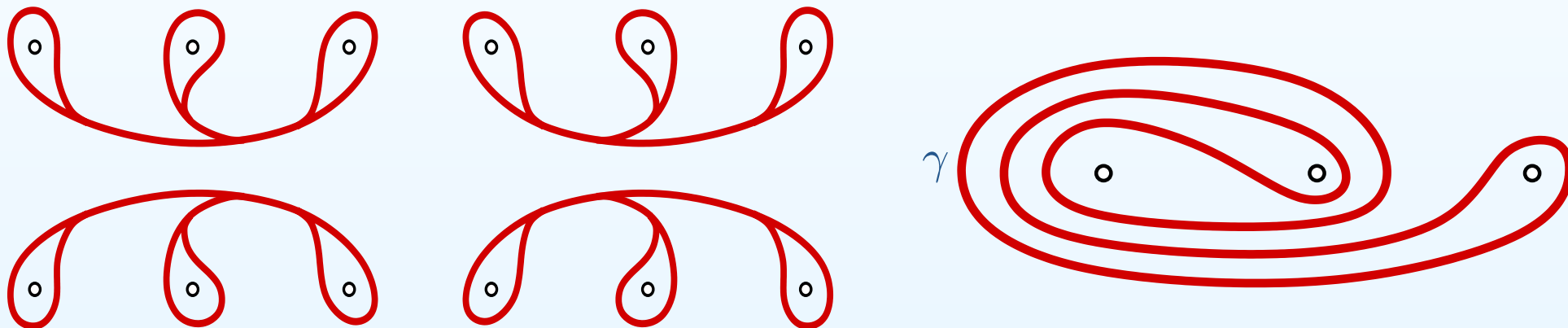

Train tracks carrying simple closed curves

Find which of the four basic train-tracks carries the simple closed curve γ on the right picture. Indicate the resulting weights.

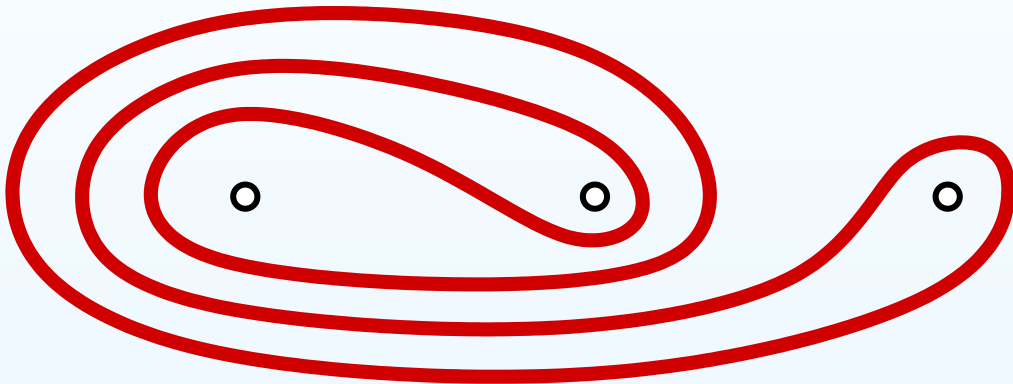

Train tracks carrying simple closed curves

Find which of the four basic train-tracks carries the simple closed curve γ on the right picture. Indicate the resulting weights.

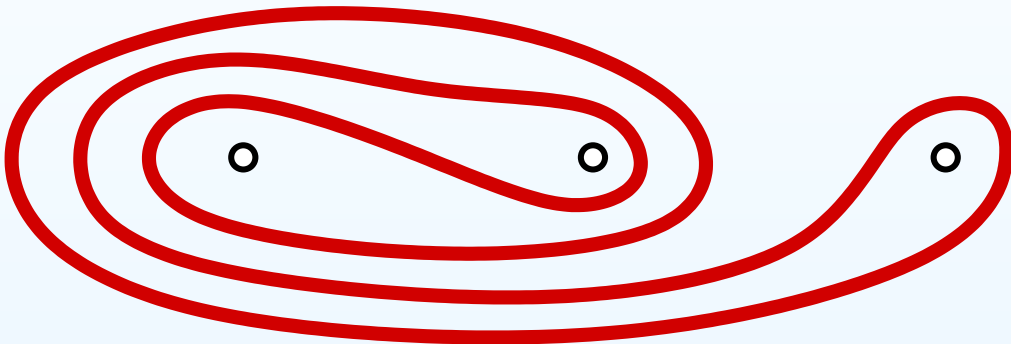

Train tracks carrying simple closed curves

Find which of the four basic train-tracks carries the simple closed curve γ on the right picture. Indicate the resulting weights.

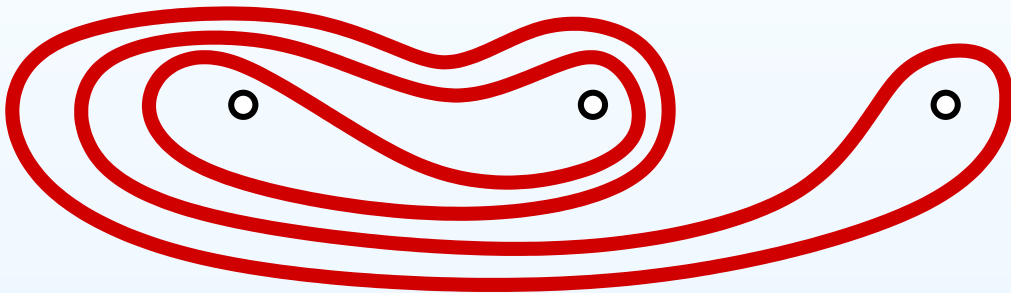

Train tracks carrying simple closed curves

Find which of the four basic train-tracks carries the simple closed curve γ on the right picture. Indicate the resulting weights.

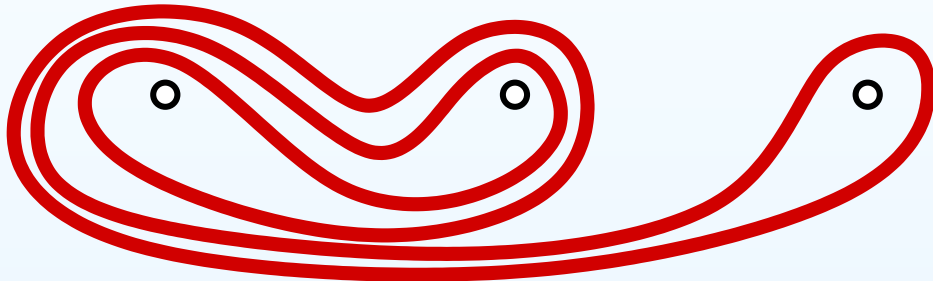

Train tracks carrying simple closed curves

Find which of the four basic train-tracks carries the simple closed curve γ on the right picture. Indicate the resulting weights.

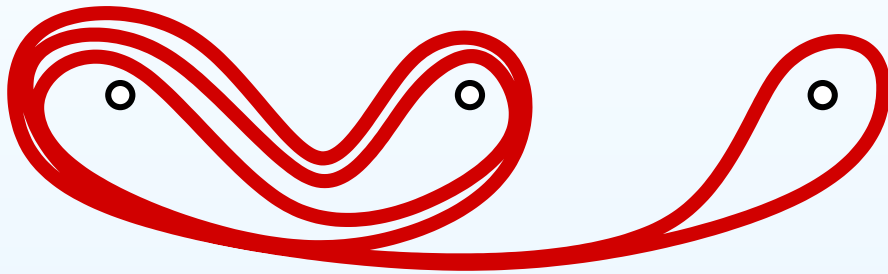

Train tracks carrying simple closed curves

Find which of the four basic train-tracks carries the simple closed curve γ on the right picture. Indicate the resulting weights.

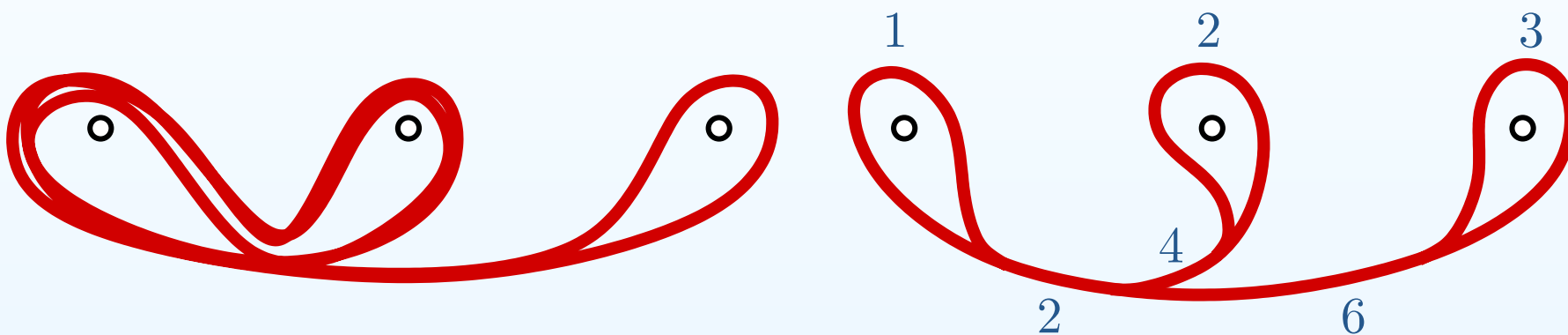

Playing with train tracks

Find a sequence of “zips” and/or “unzips” which deform the given train track τ of the right picture to one of the four “basic” train tracks τ_1, \dots, τ_4 . Indicate the weights of all branches of the initial and of the final train tracks.

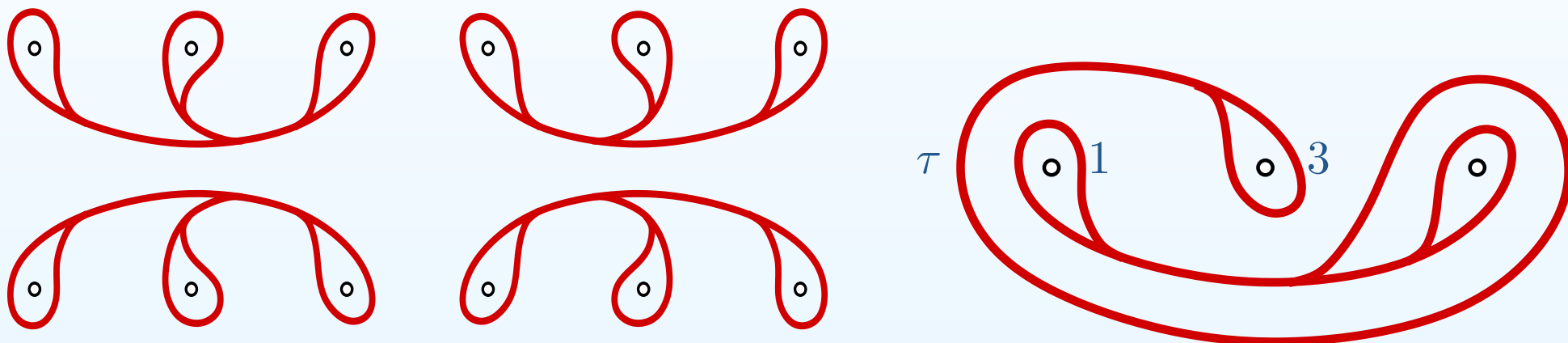

Zippering and unzipping train tracks

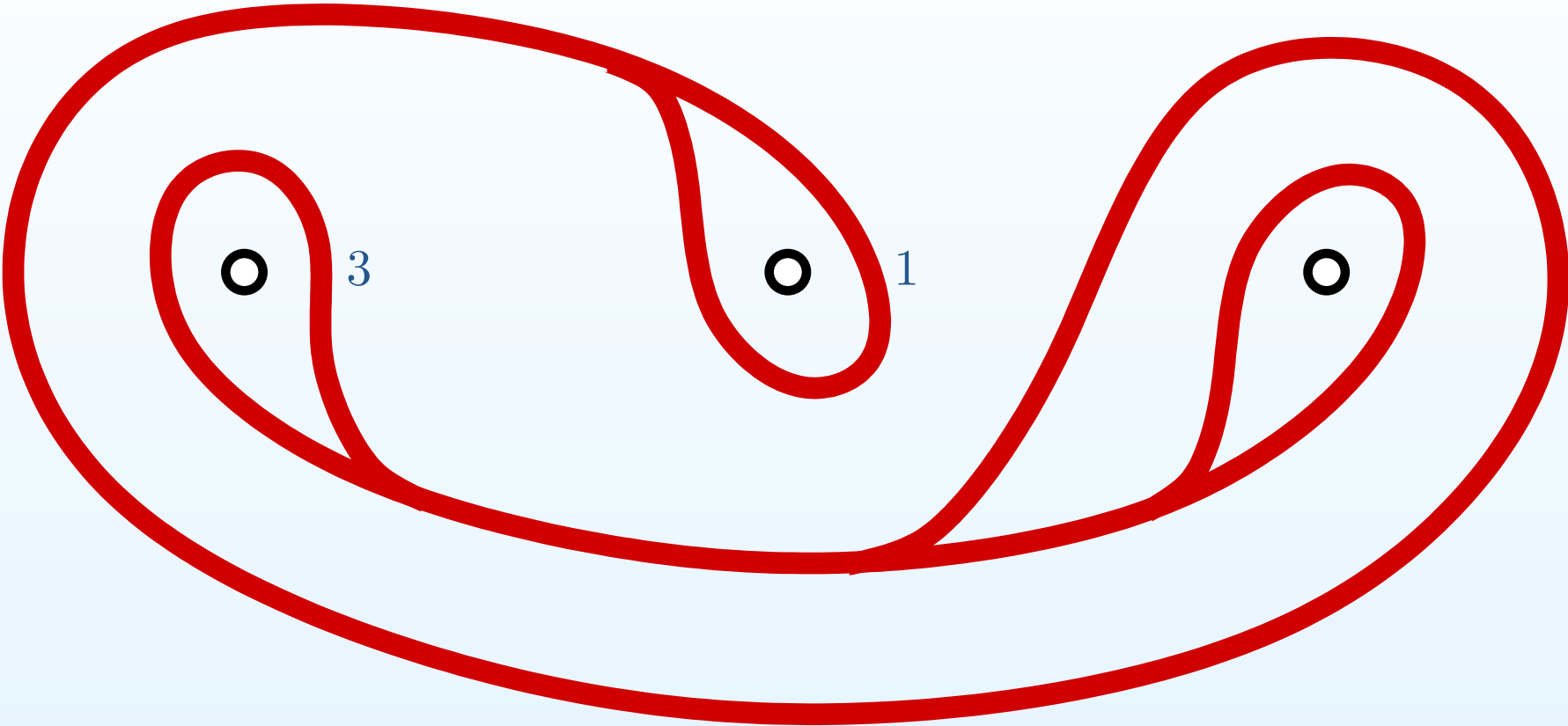

Zippering and unzipping train tracks

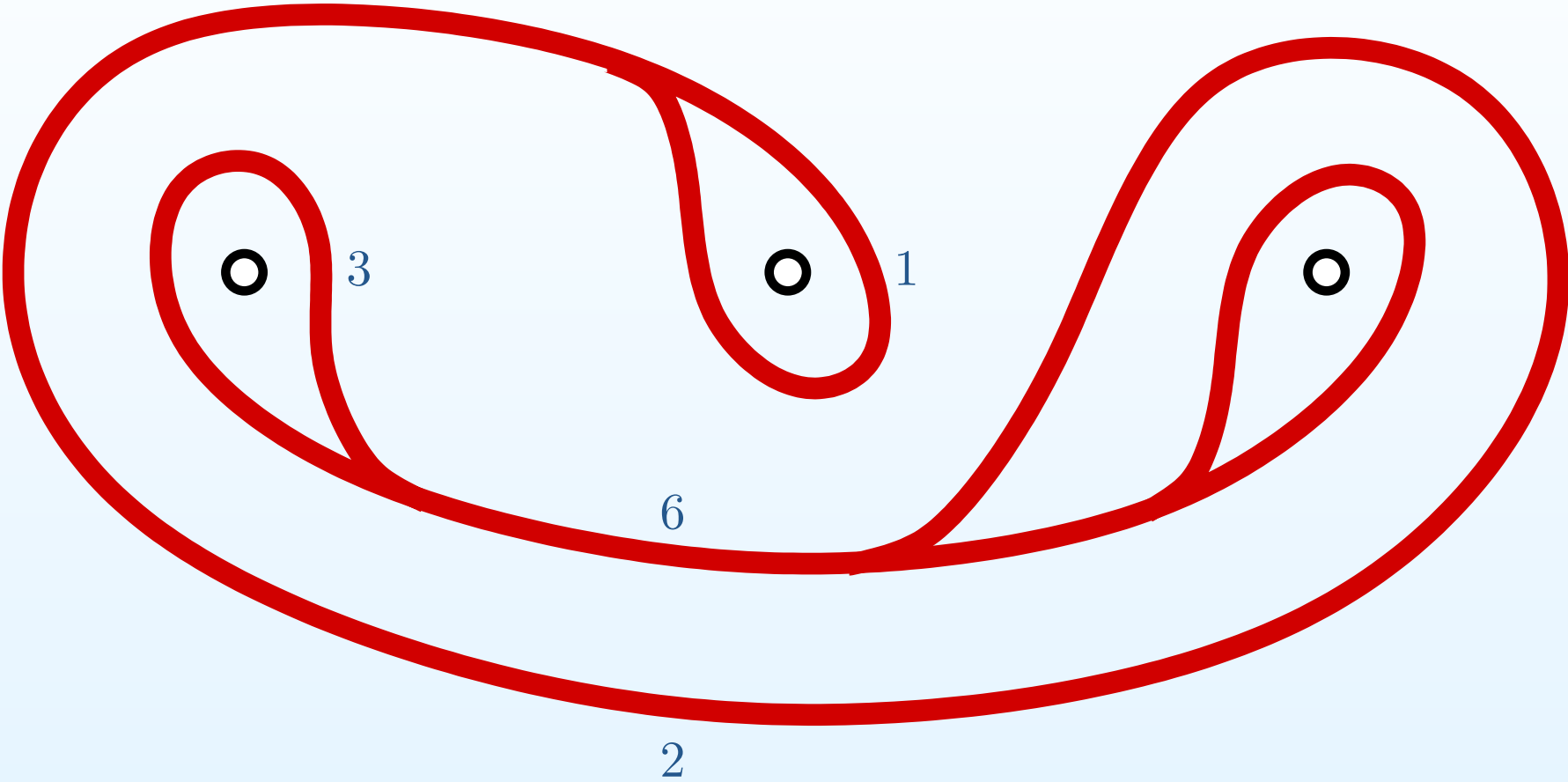

Zippering and unzipping train tracks

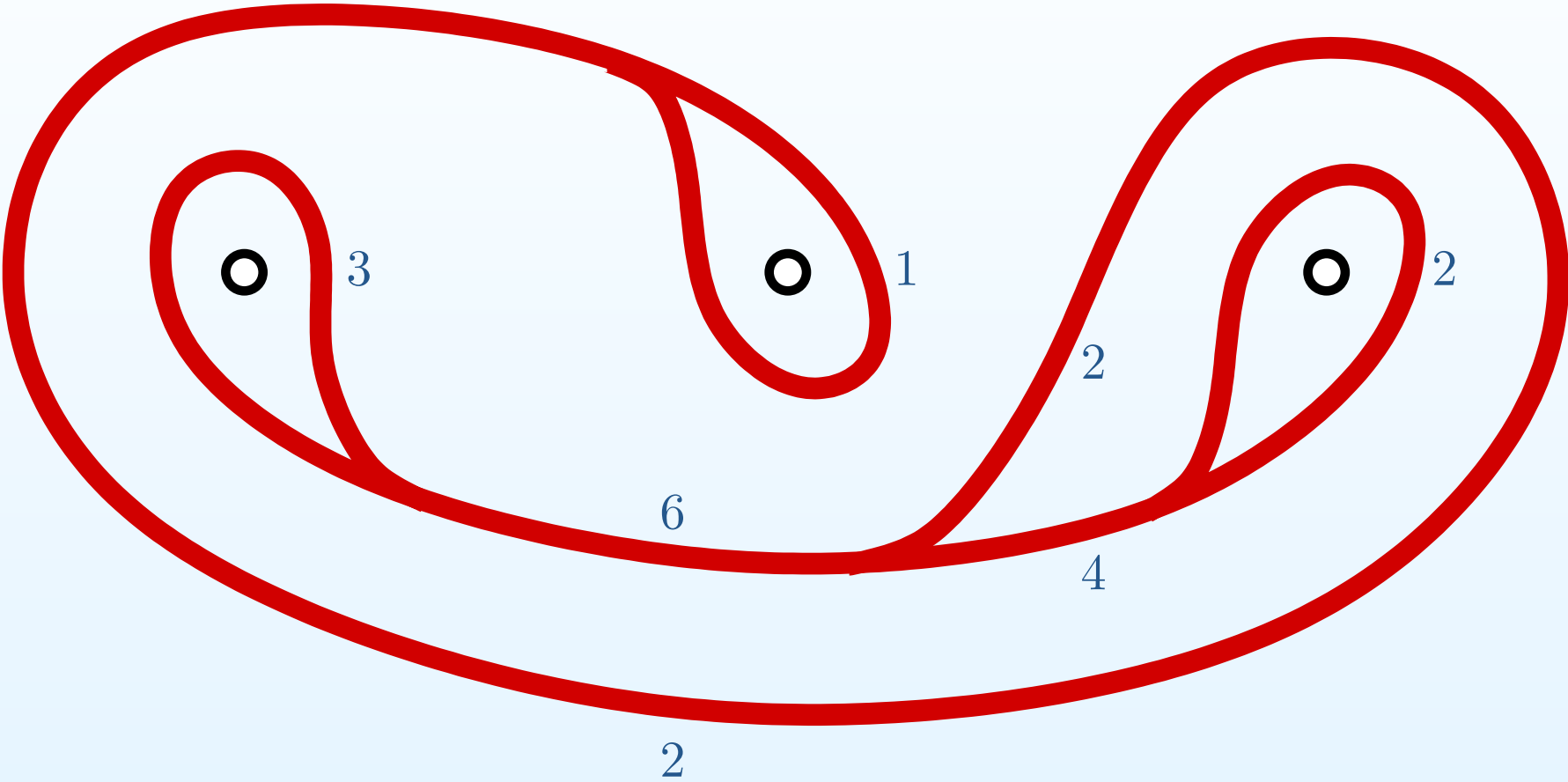

Zippering and unzipping train tracks

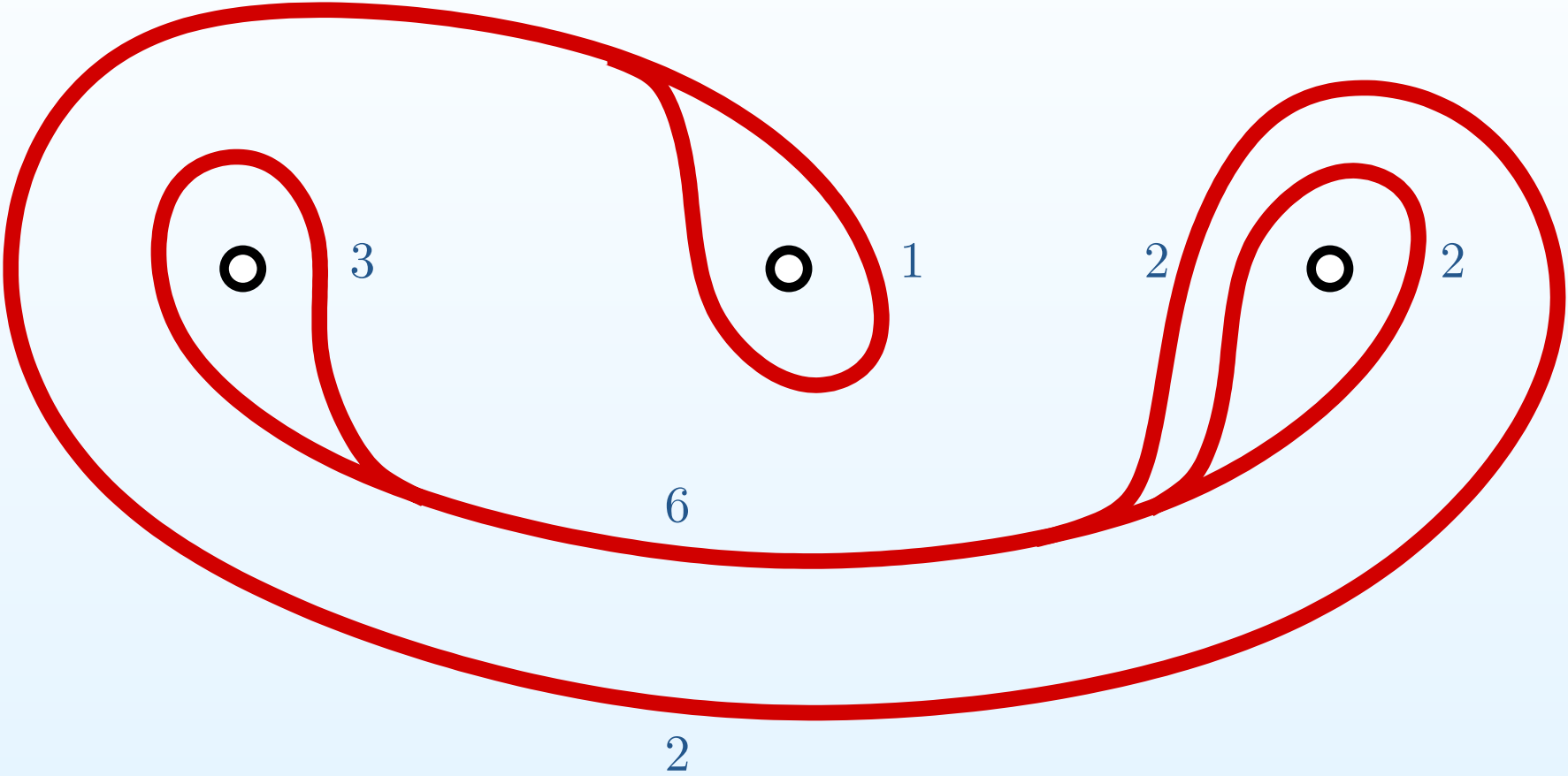

Zippering and unzipping train tracks

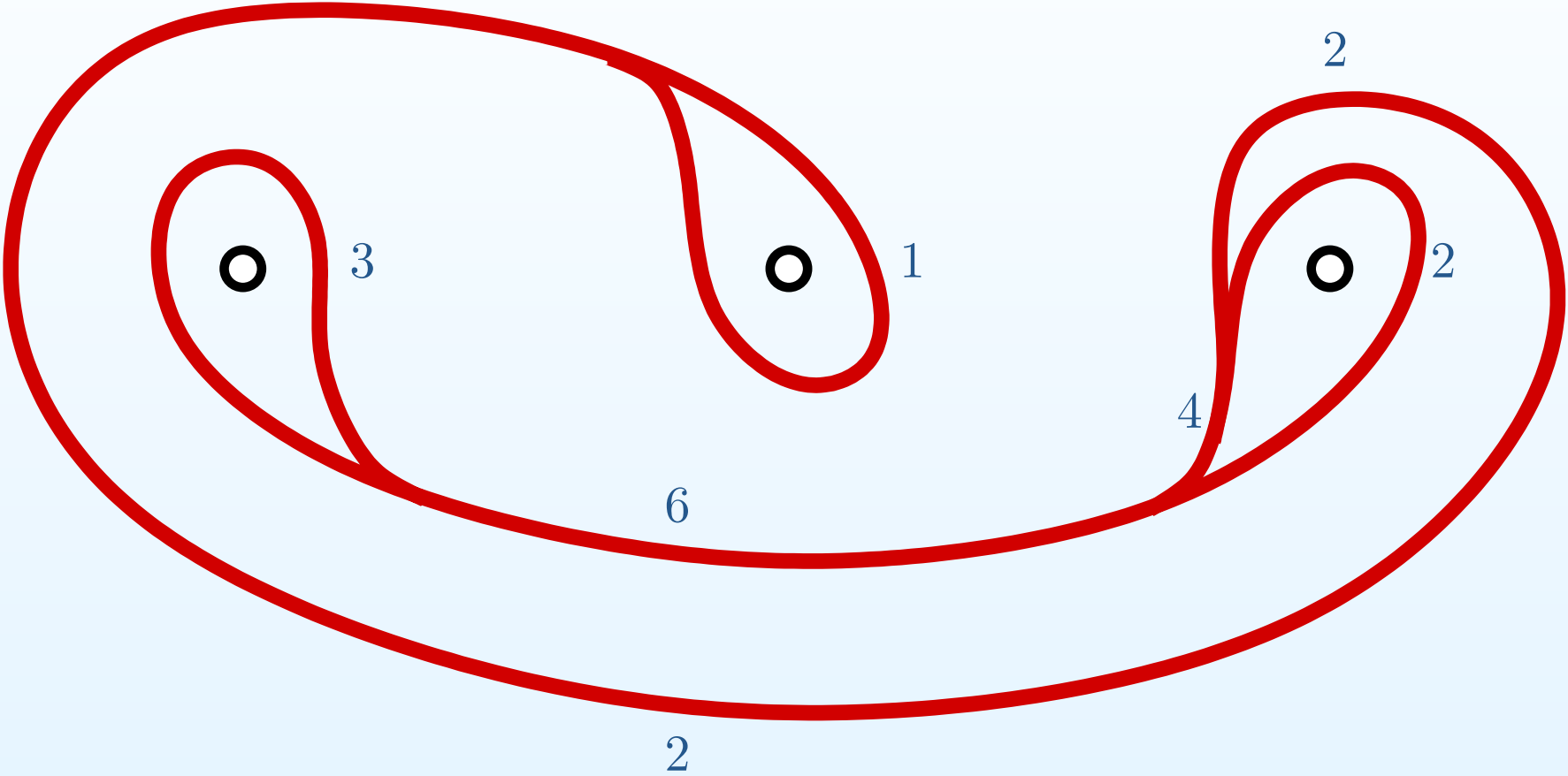

Zippering and unzipping train tracks

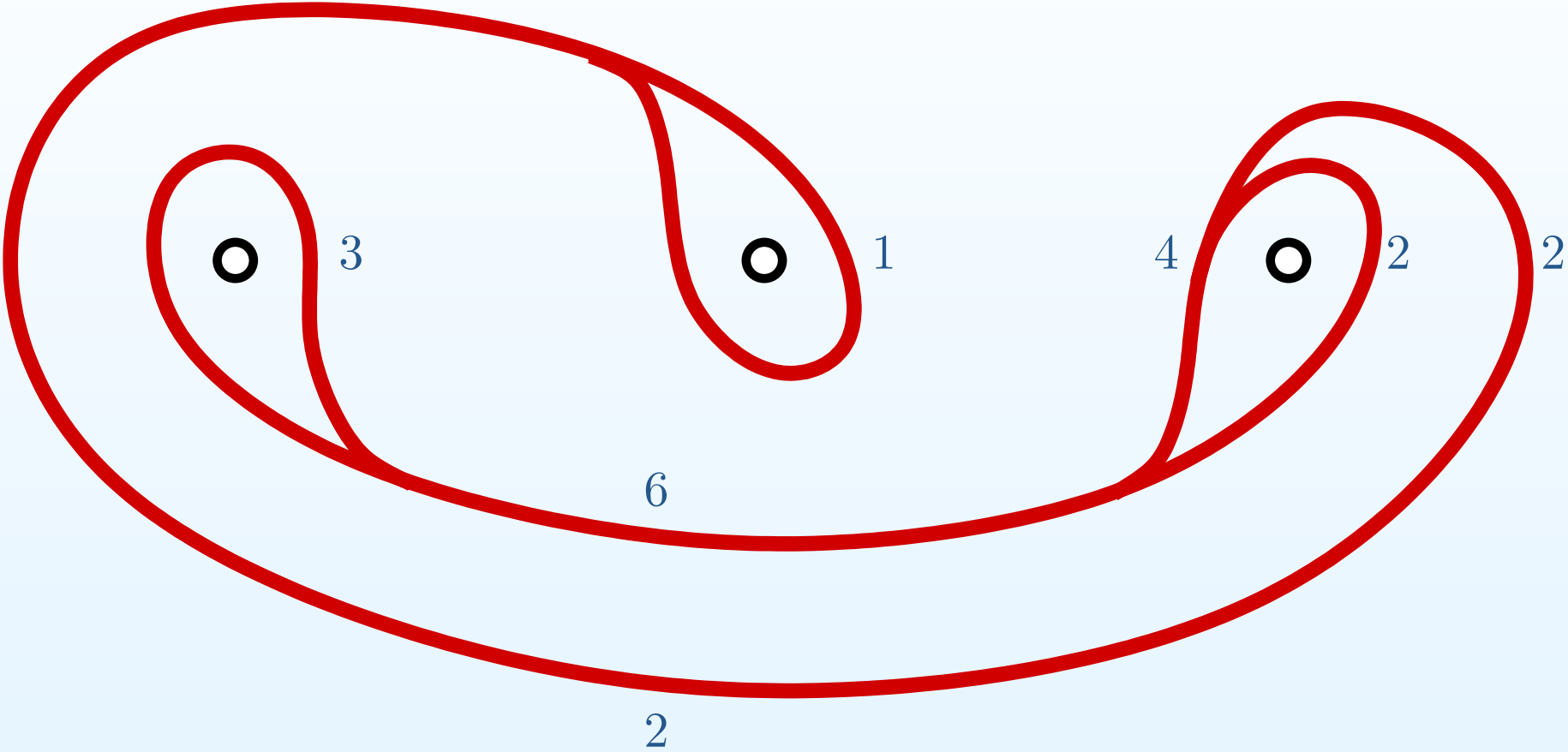

Zippering and unzipping train tracks

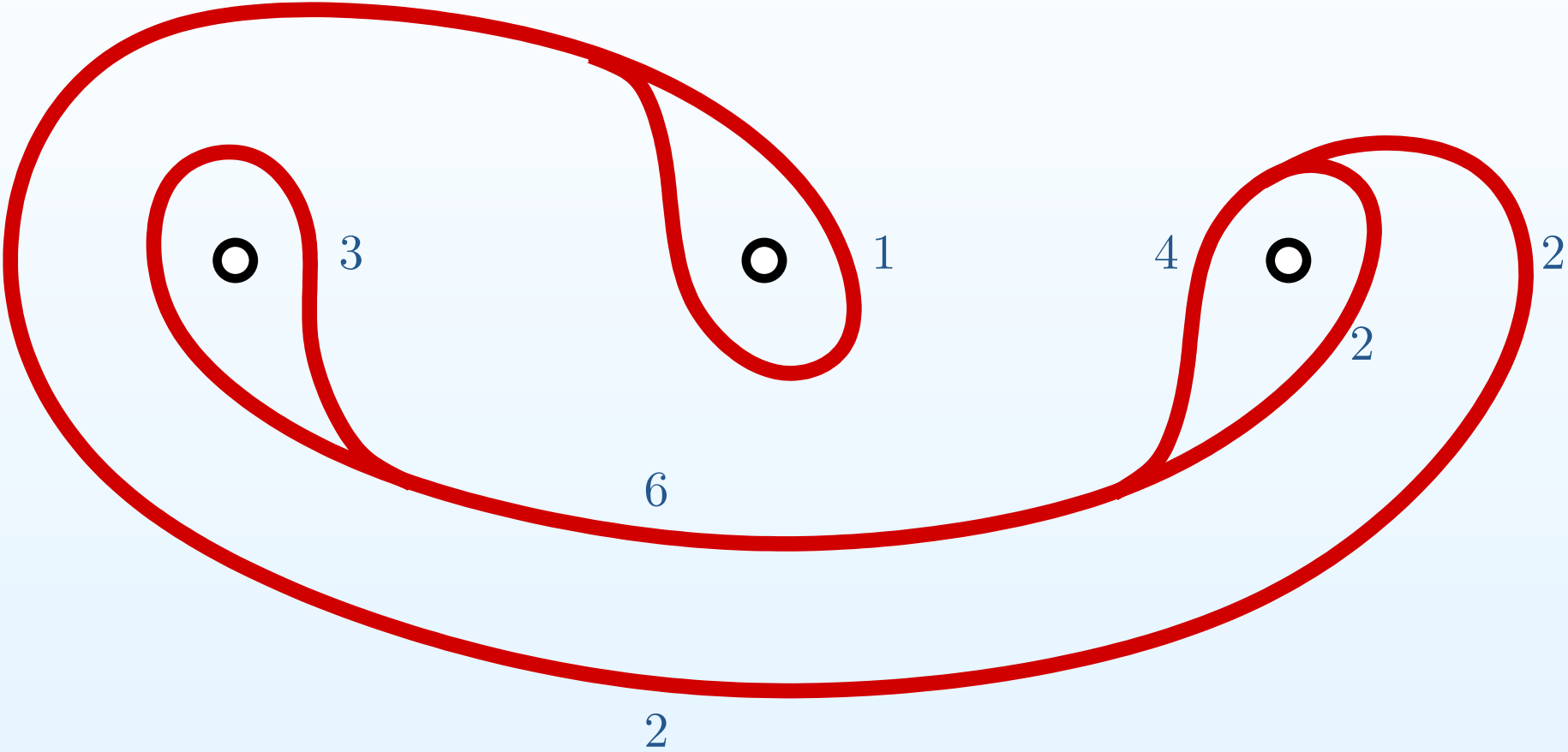

Zippering and unzipping train tracks

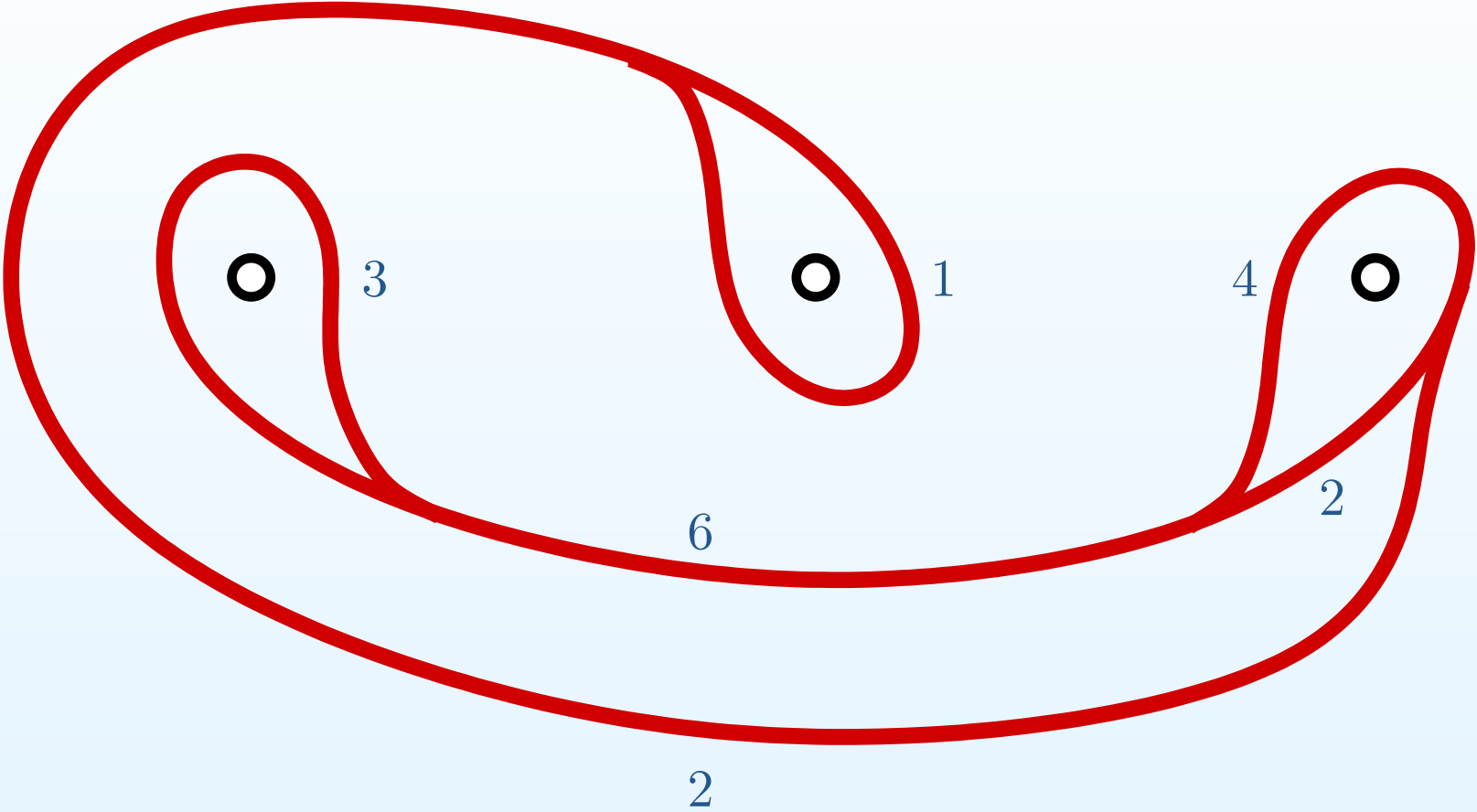

Zippering and unzipping train tracks

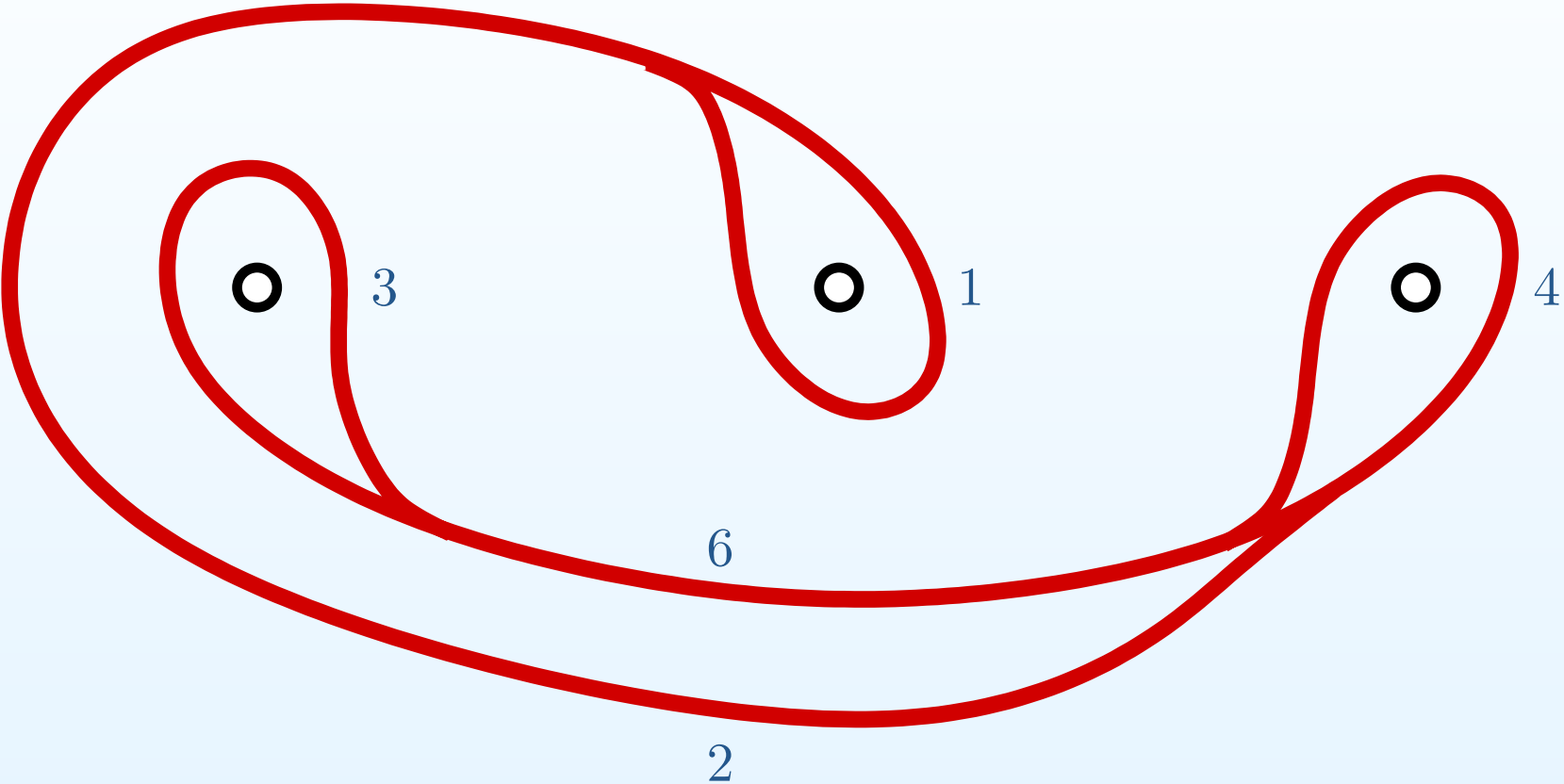

Zippering and unzipping train tracks

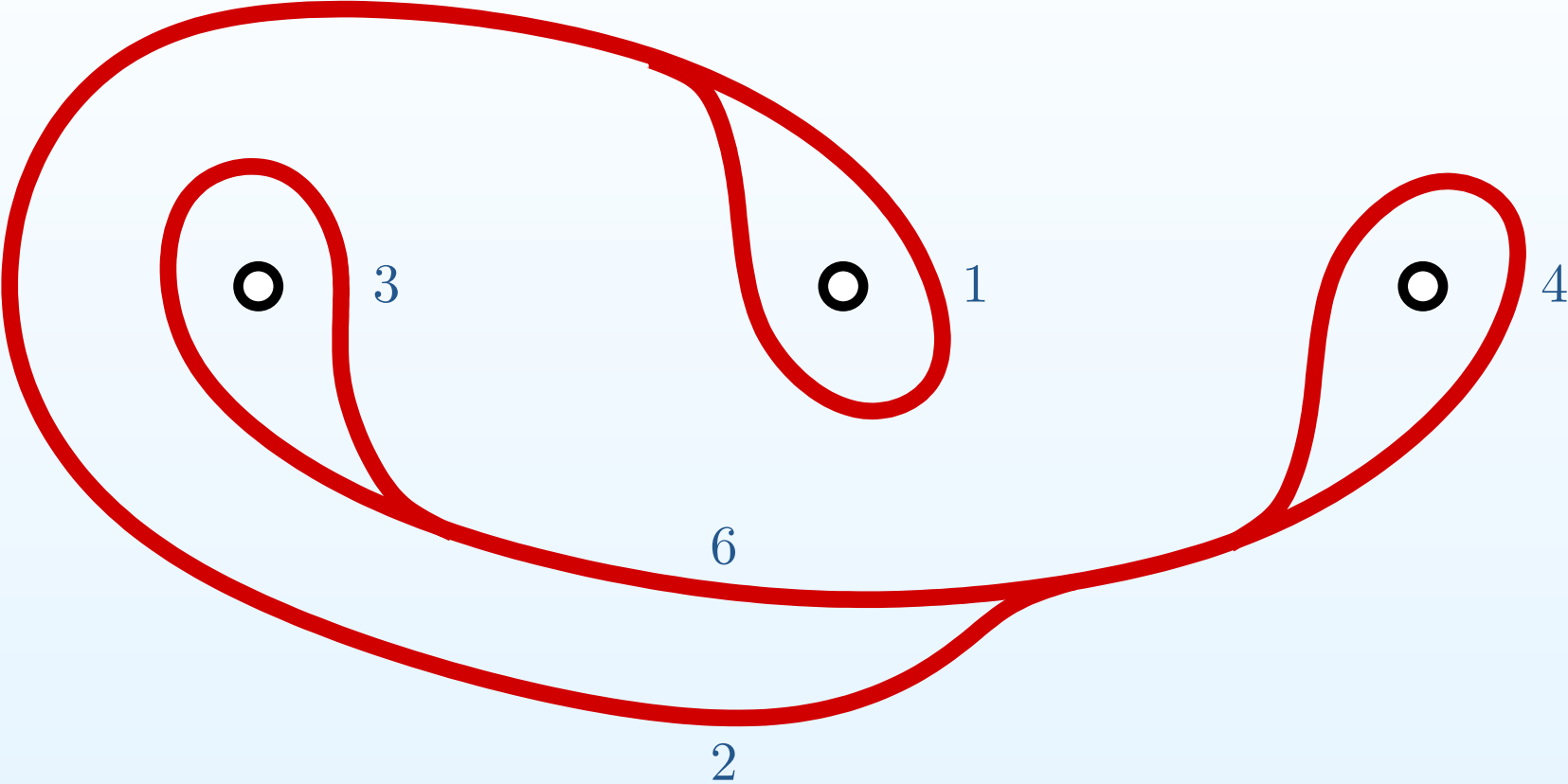

Zippering and unzipping train tracks

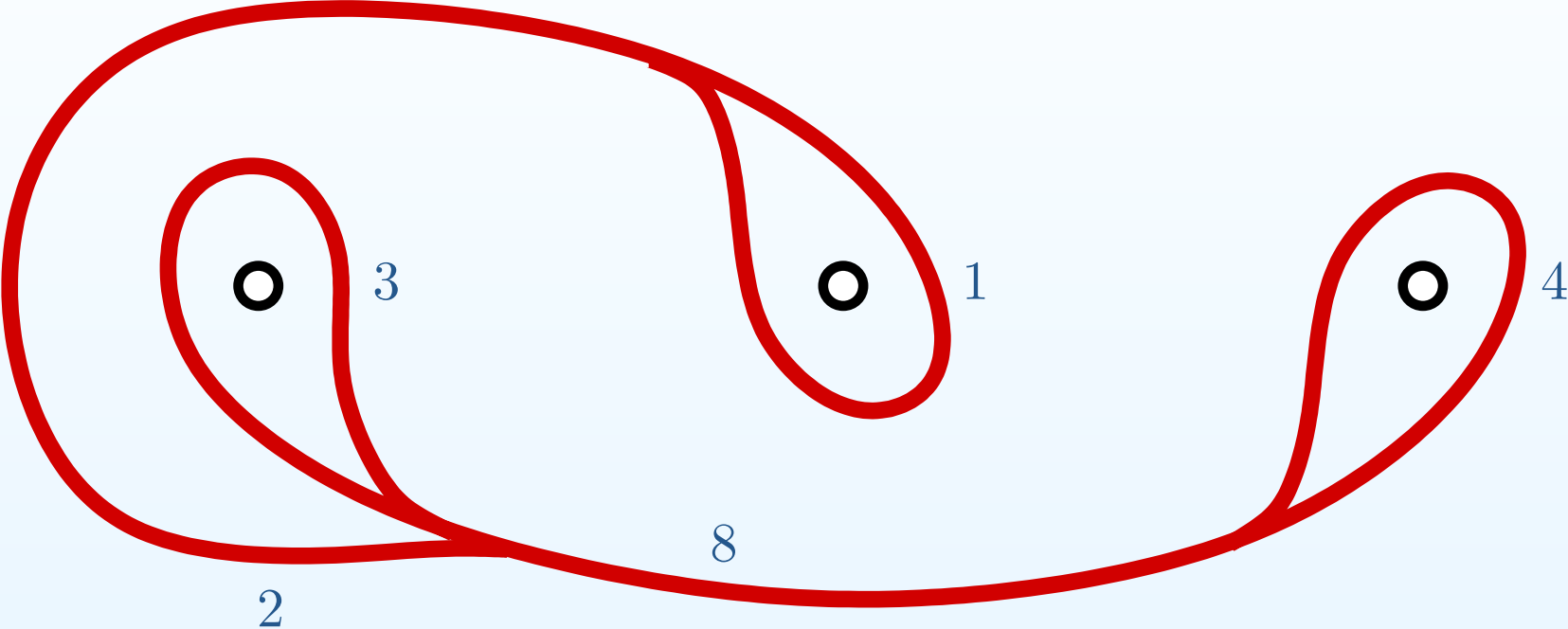

Zippering and unzipping train tracks

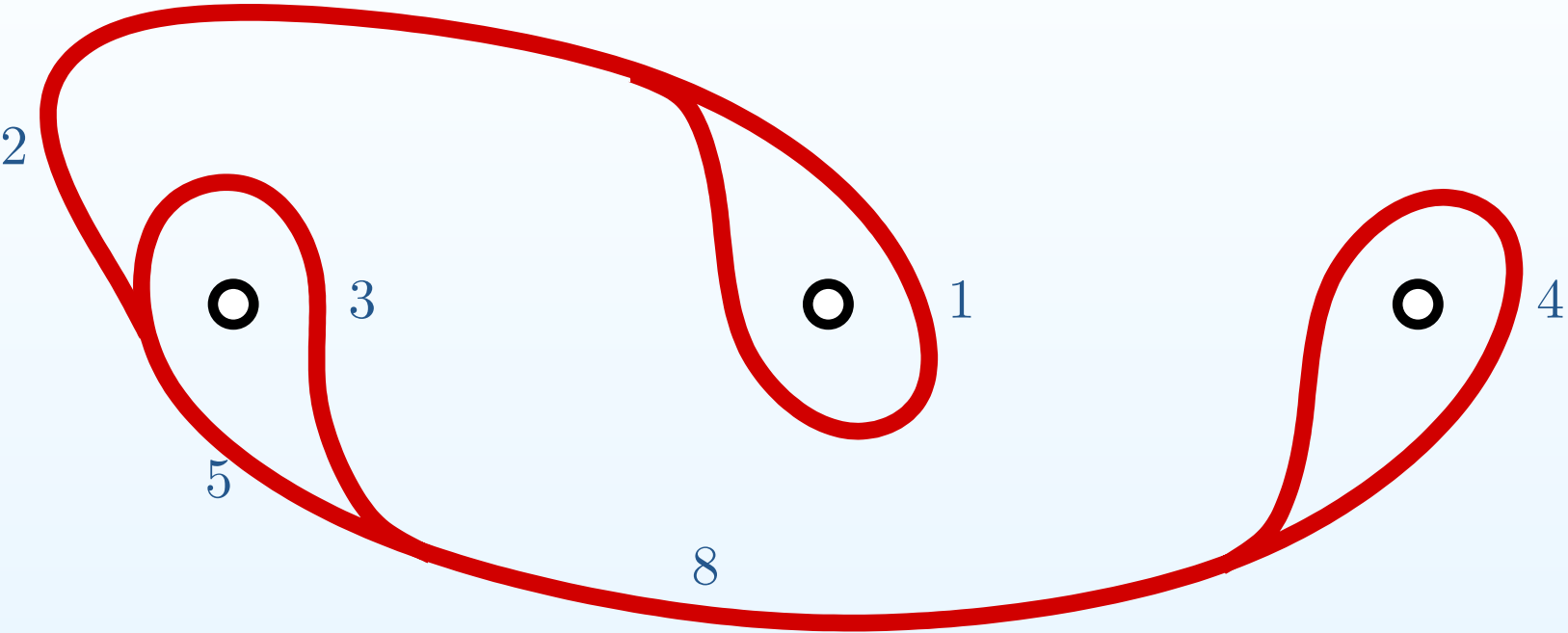

Zippering and unzipping train tracks

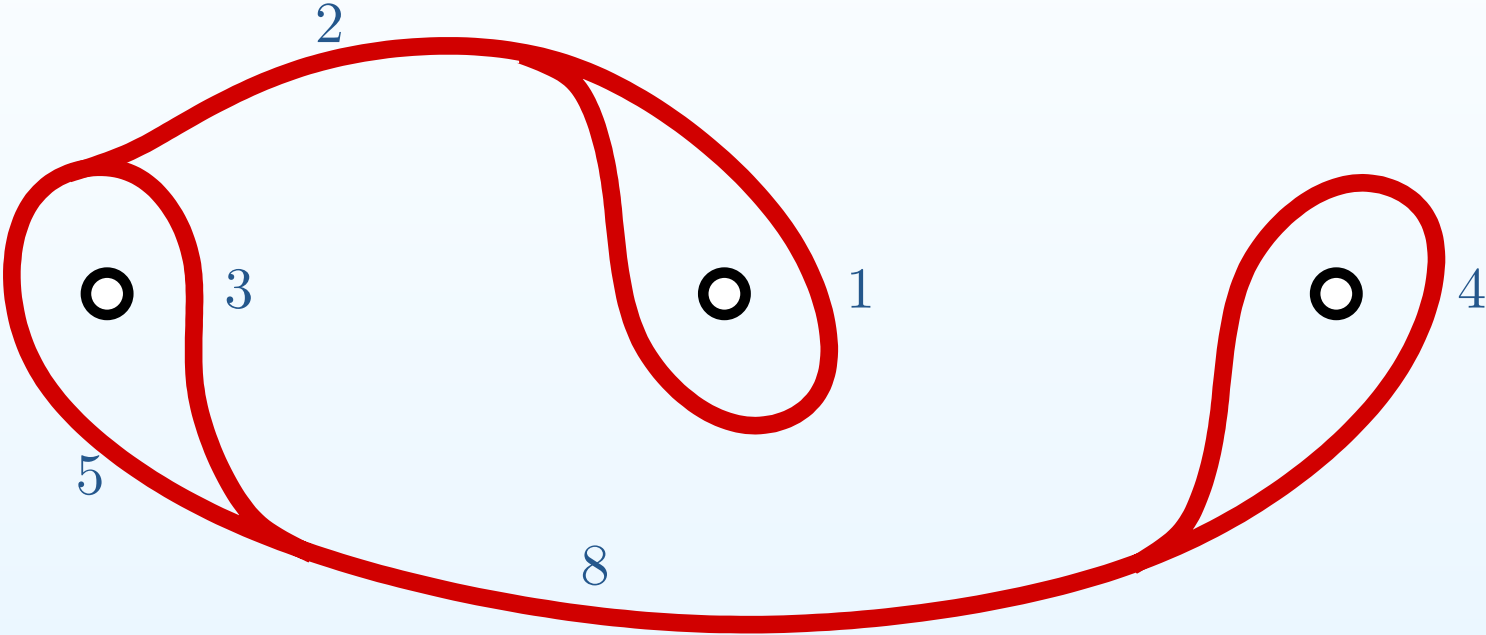

Zippering and unzipping train tracks

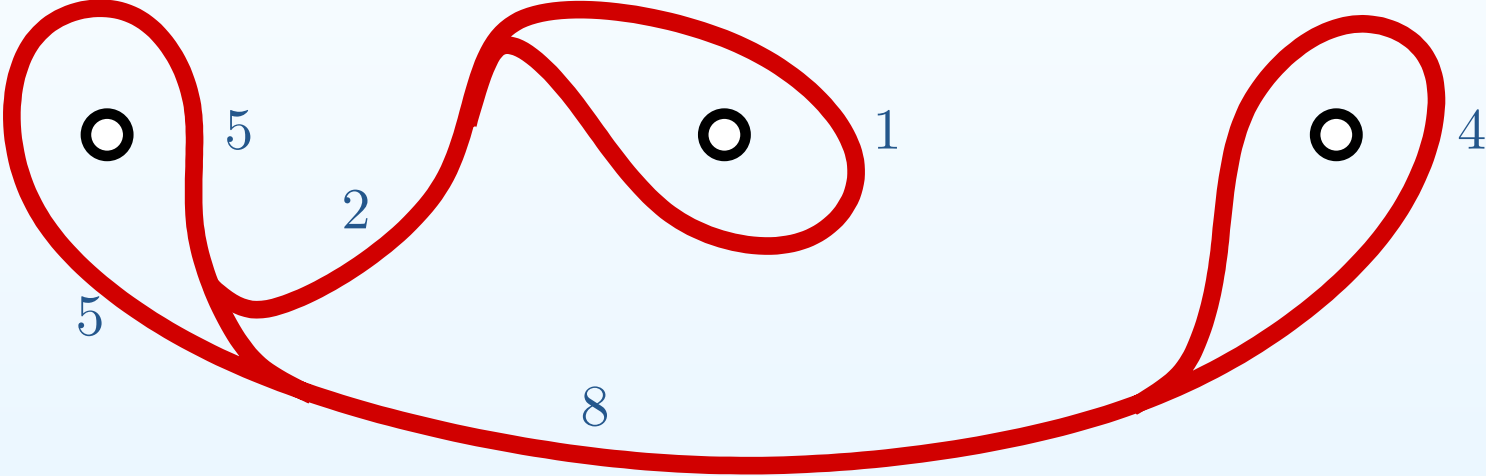

Zippering and unzipping train tracks

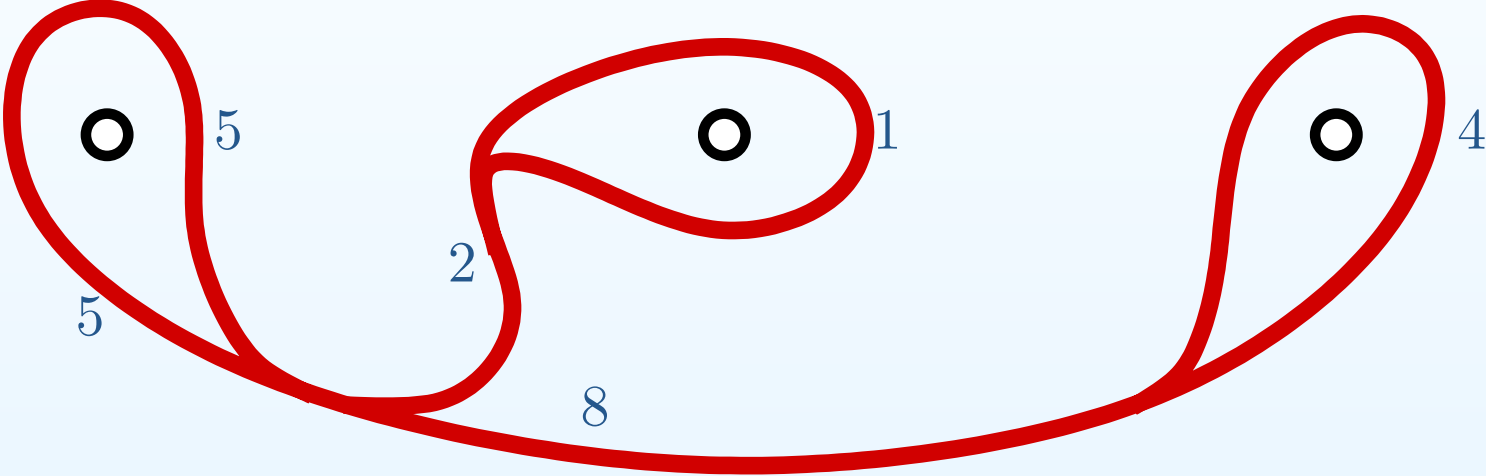

Zippering and unzipping train tracks

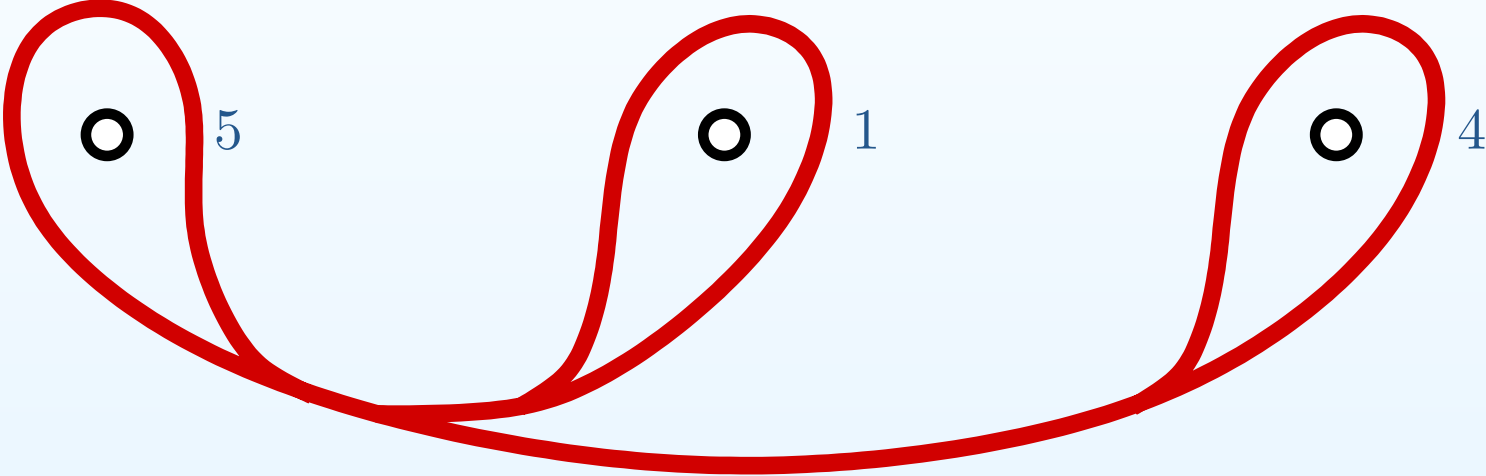

Parity of the spin-structure

- Check that the following two flat surfaces belong to the stratum $\mathcal{H}(4)$.

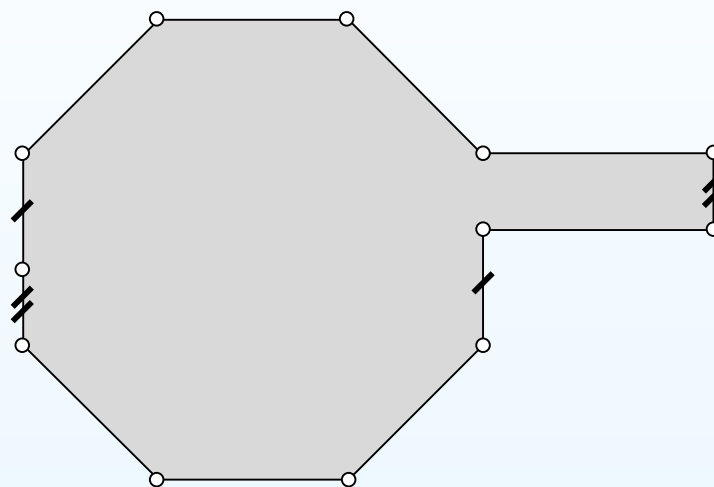
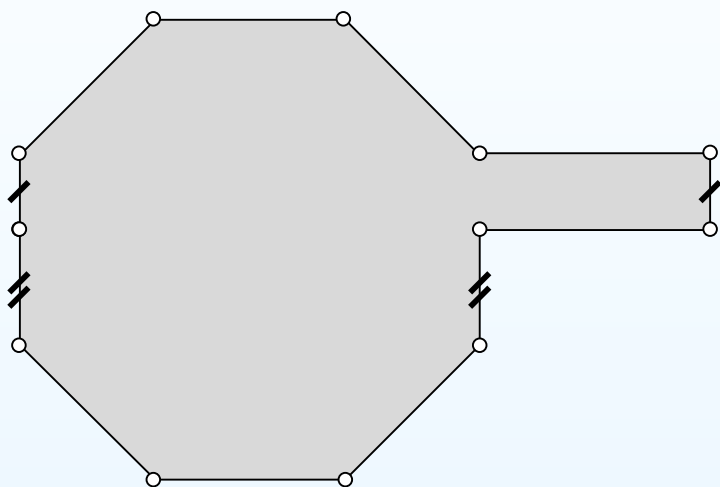

- Compute the parity of the spin structure for these surfaces (and notice that it is not the same).
- Determine which of the two surfaces is hyperelliptic.
- Find the hyperelliptic involution of this surface in geometric terms. Find the Weierstrass points (the fixed points of the hyperelliptic involution). Check that there are $2g + 2$ such points.

- Proof that the following flat surface belongs to the stratum $\mathcal{H}(4)$.

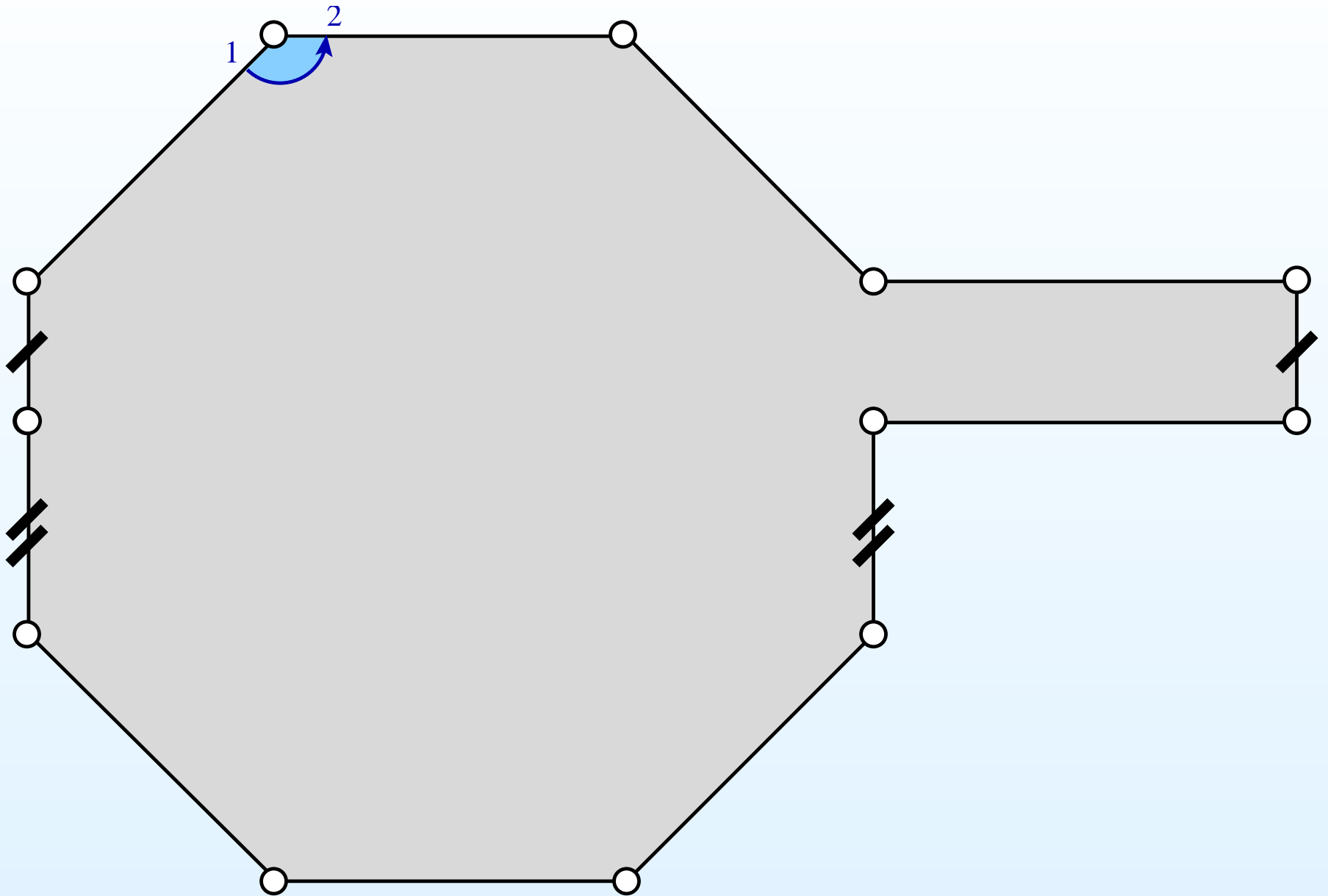

- Proof that the following flat surface belongs to the stratum $\mathcal{H}(4)$.

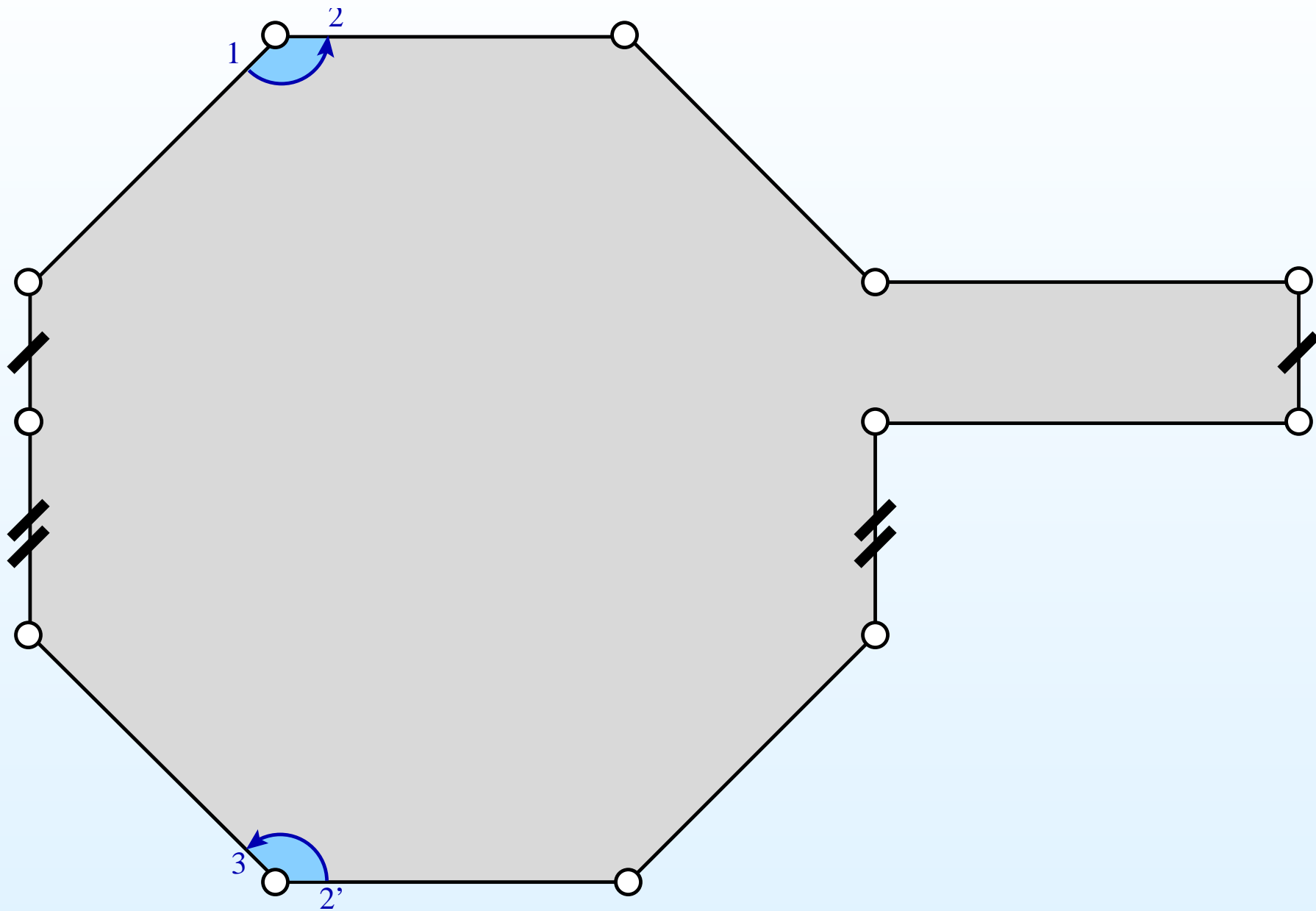

- Proof that the following flat surface belongs to the stratum $\mathcal{H}(4)$.

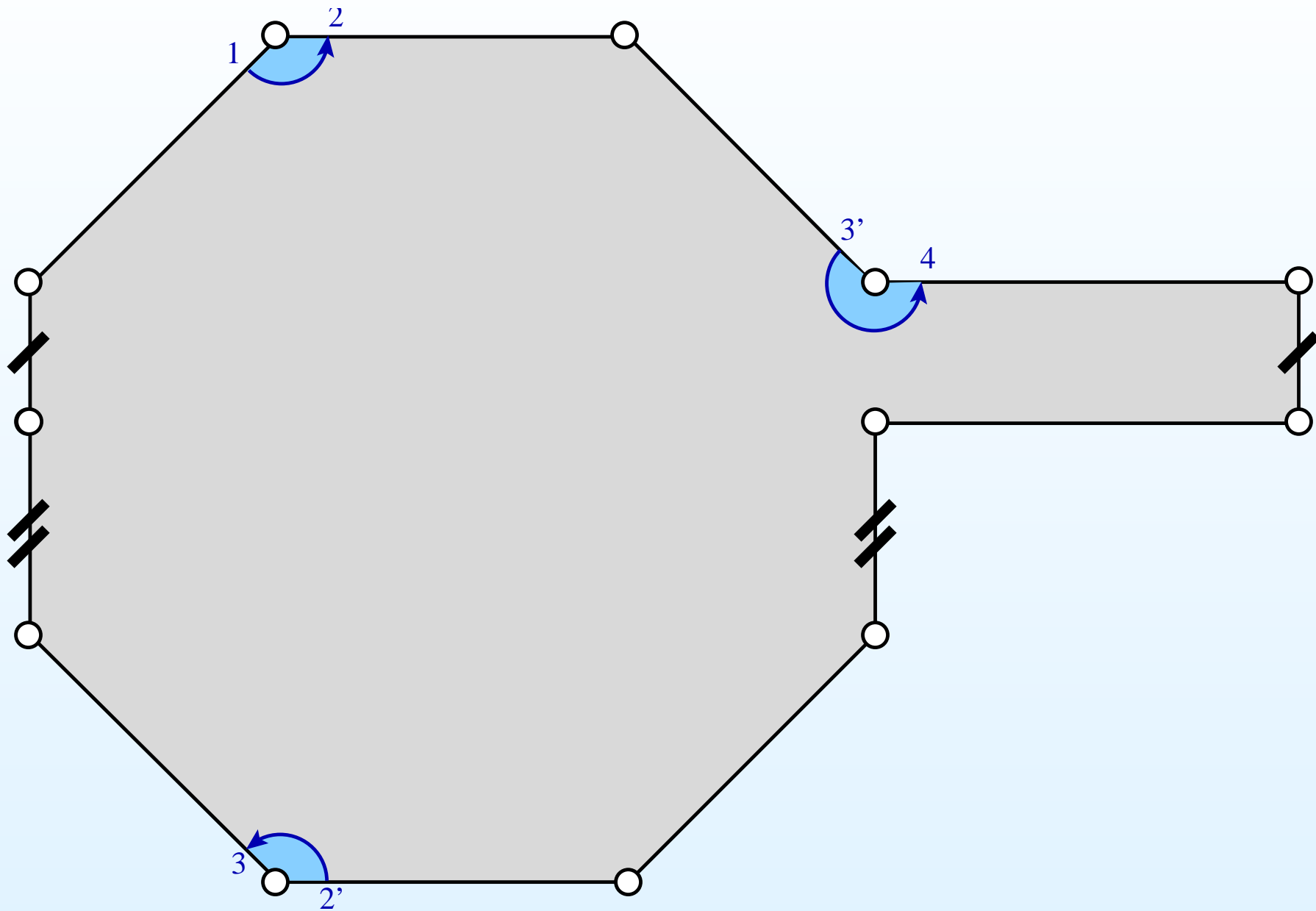

- Proof that the following flat surface belongs to the stratum $\mathcal{H}(4)$.

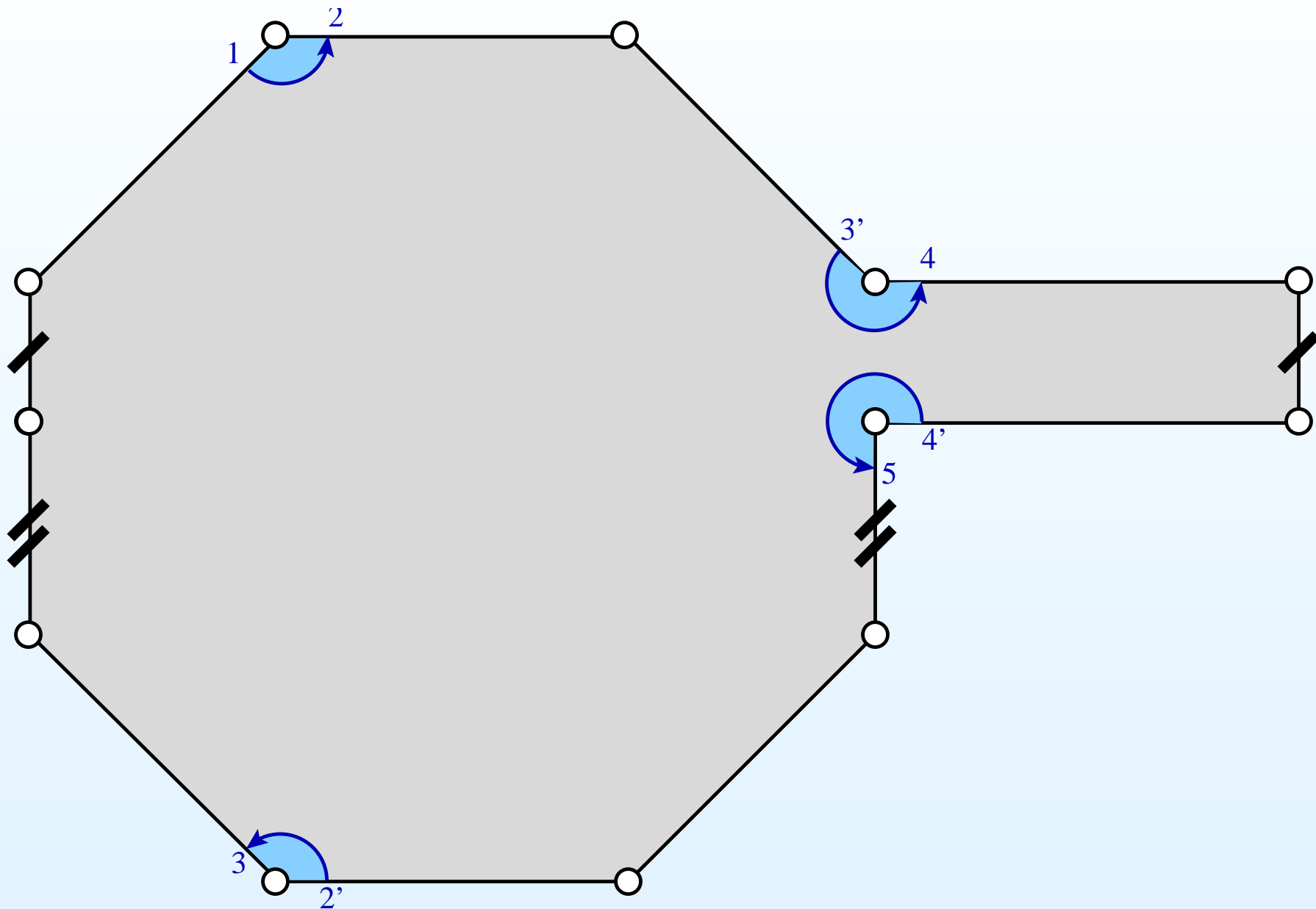

- Proof that the following flat surface belongs to the stratum $\mathcal{H}(4)$.

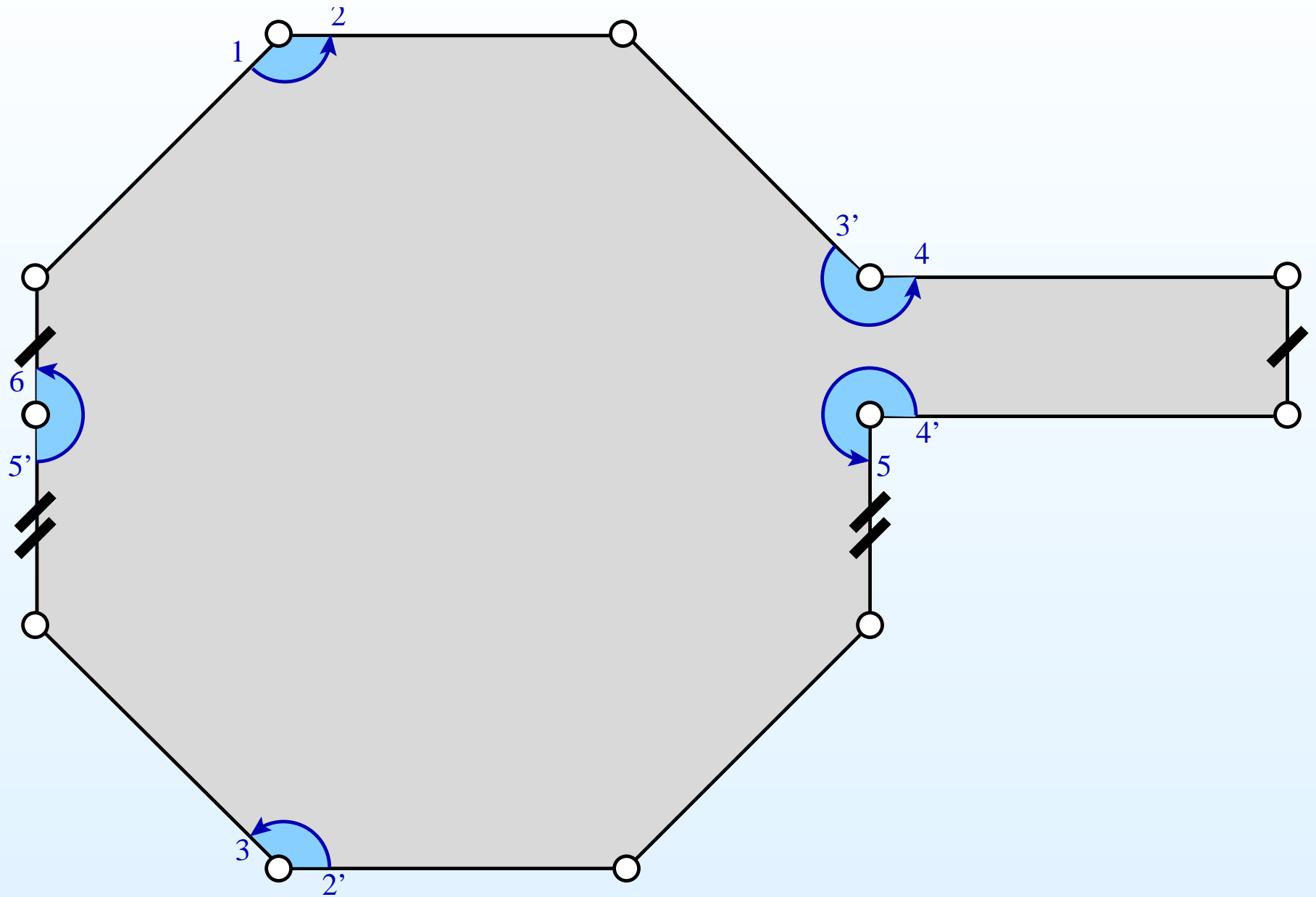

- Proof that the following flat surface belongs to the stratum $\mathcal{H}(4)$.

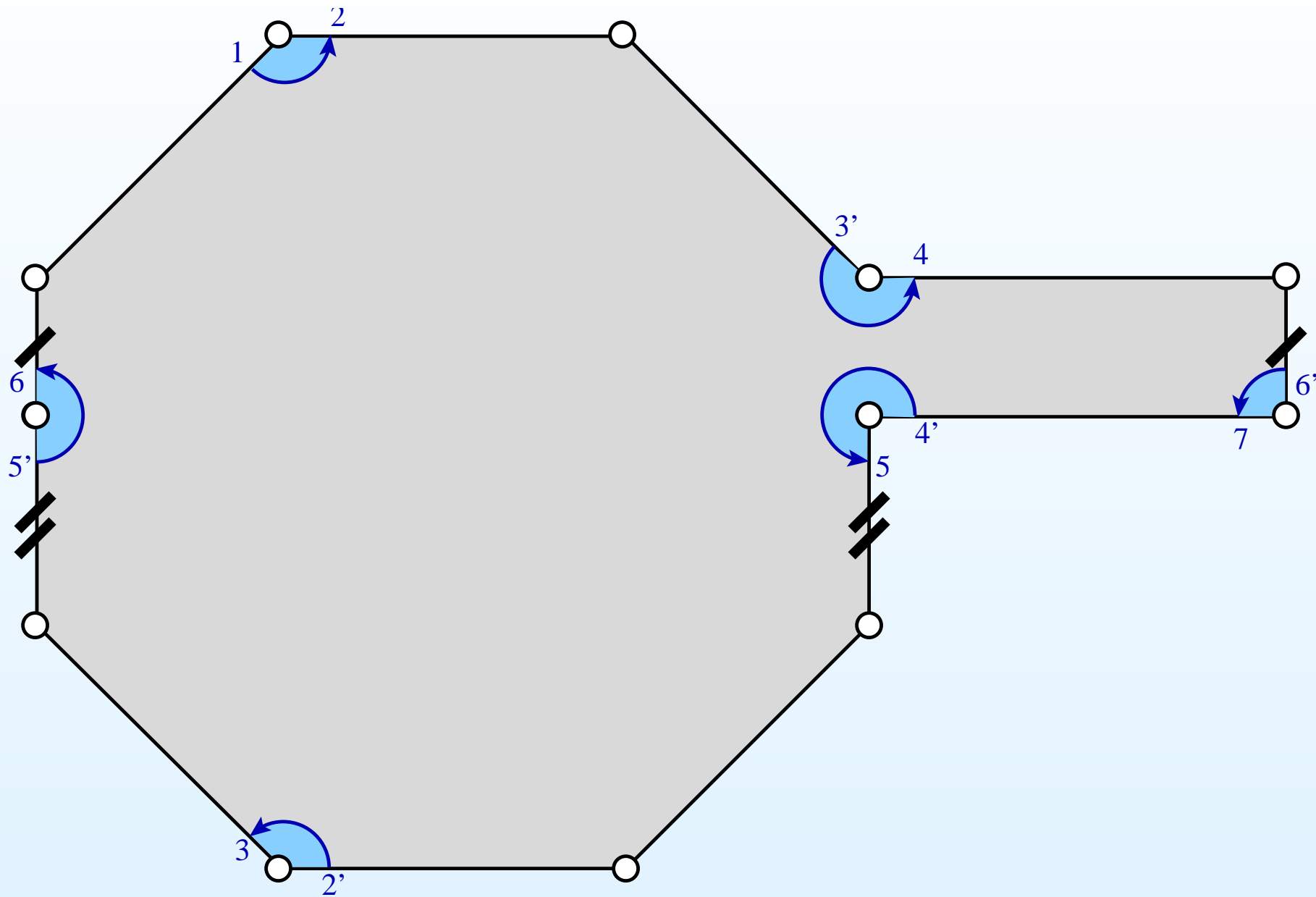

- Proof that the following flat surface belongs to the stratum $\mathcal{H}(4)$.

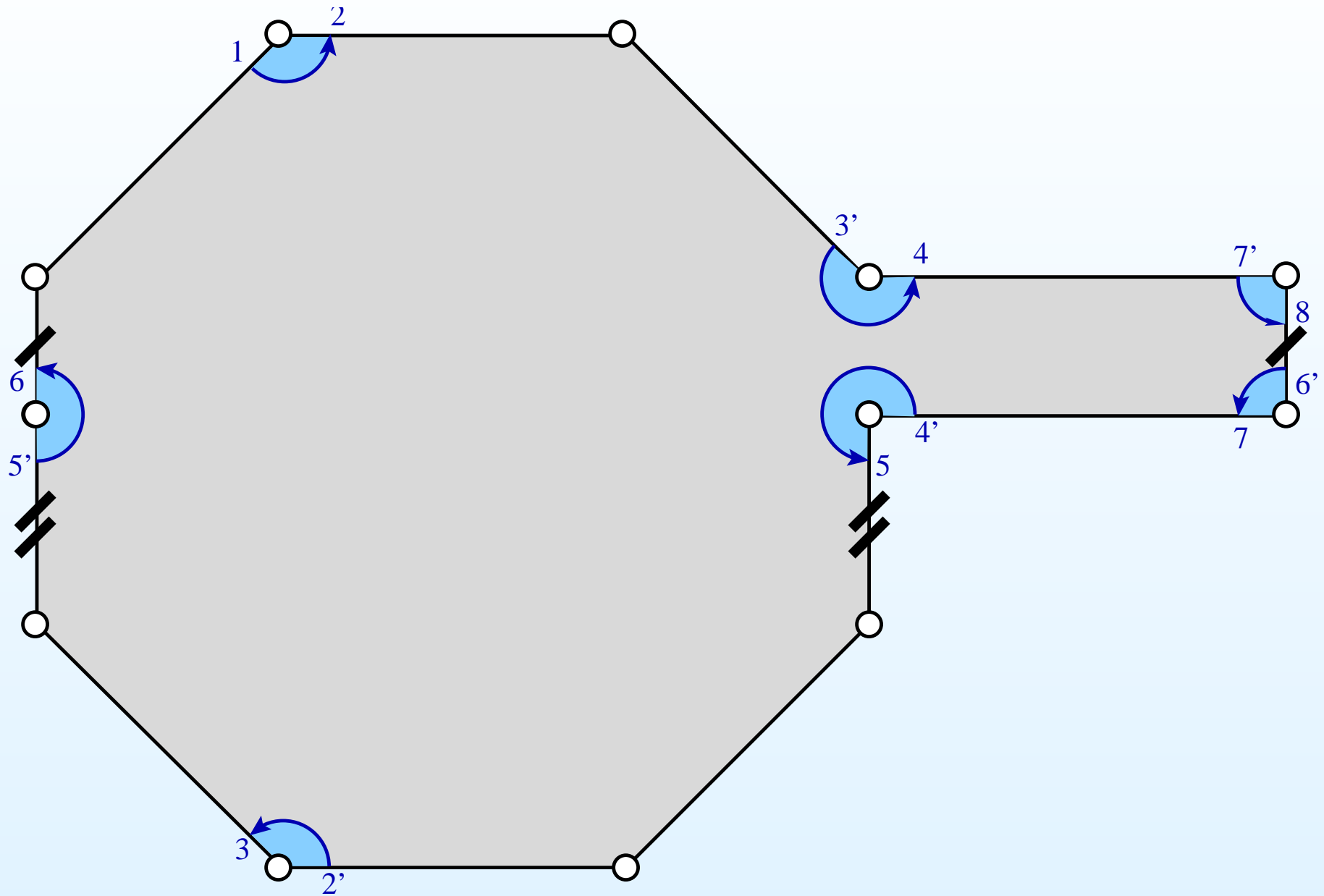

- Proof that the following flat surface belongs to the stratum $\mathcal{H}(4)$.

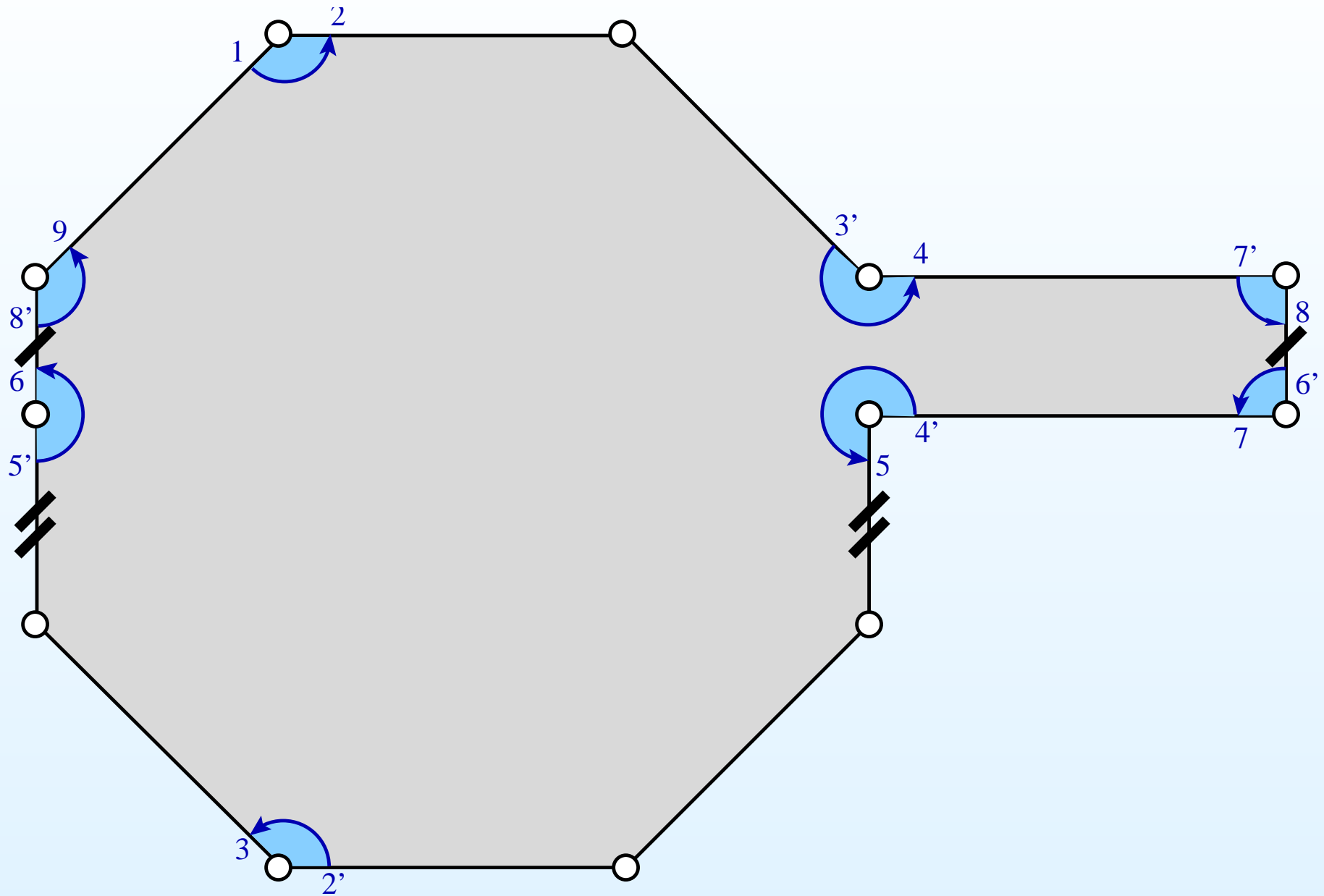

- Proof that the following flat surface belongs to the stratum $\mathcal{H}(4)$.

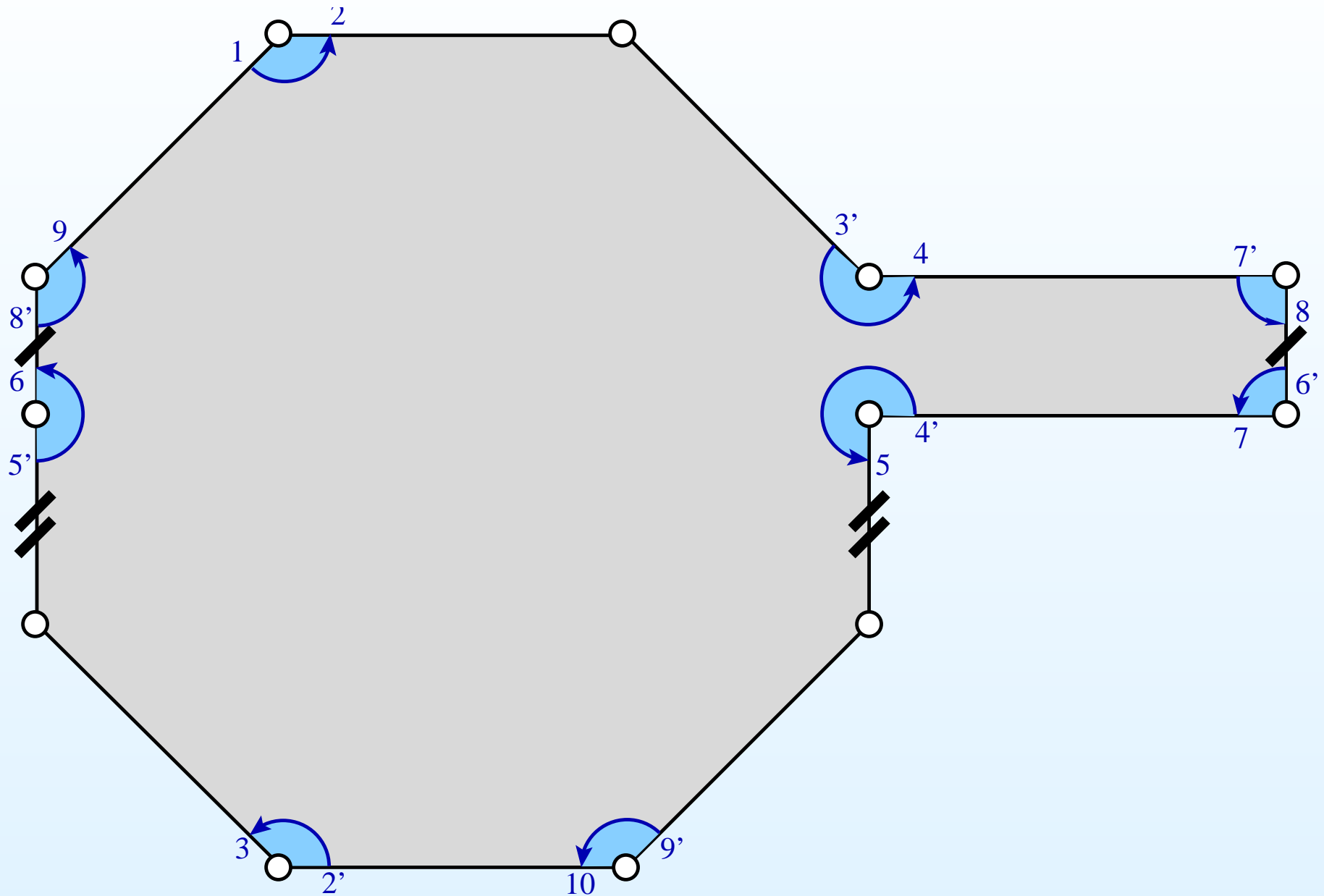

- Proof that the following flat surface belongs to the stratum $\mathcal{H}(4)$.

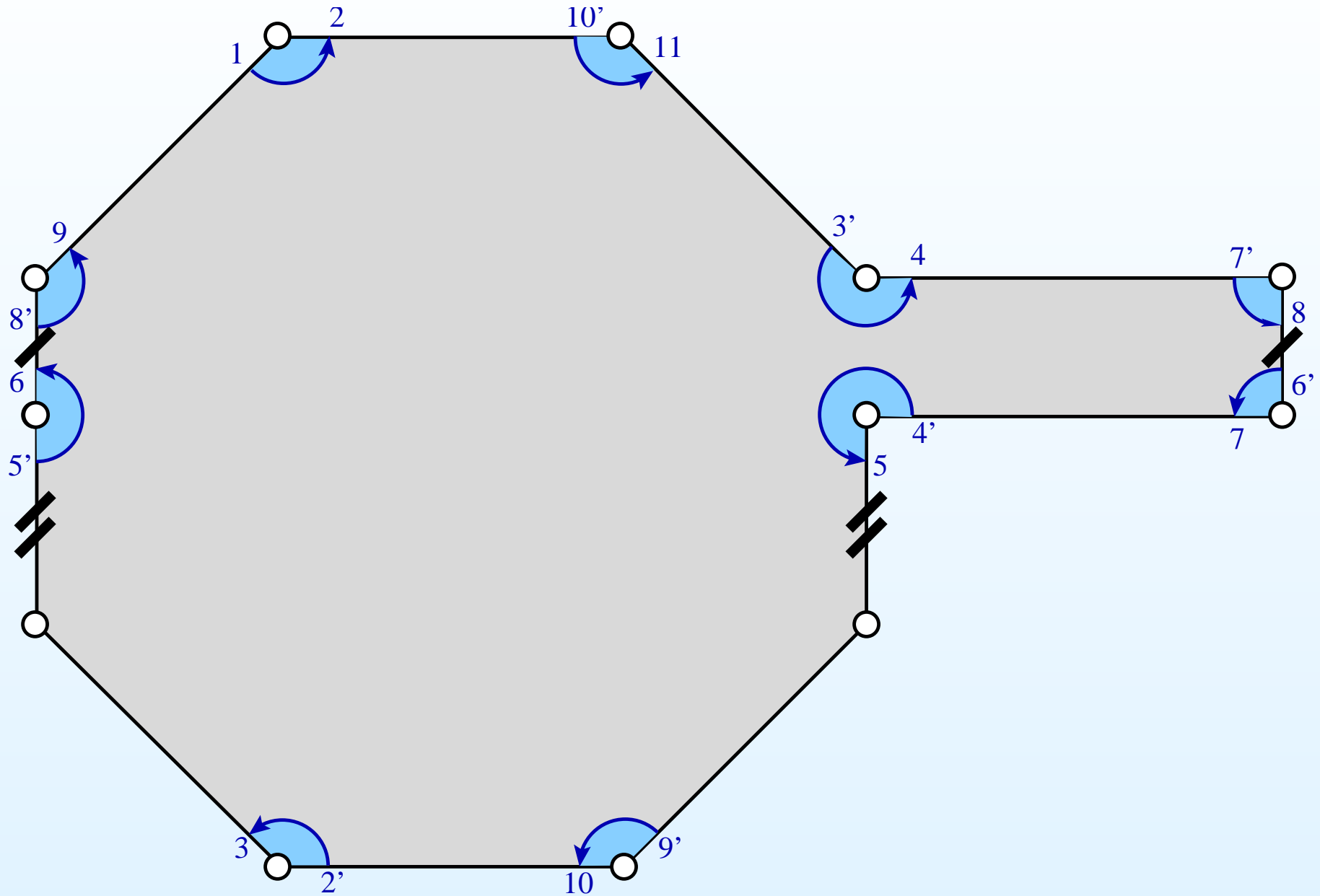

- Proof that the following flat surface belongs to the stratum $\mathcal{H}(4)$.

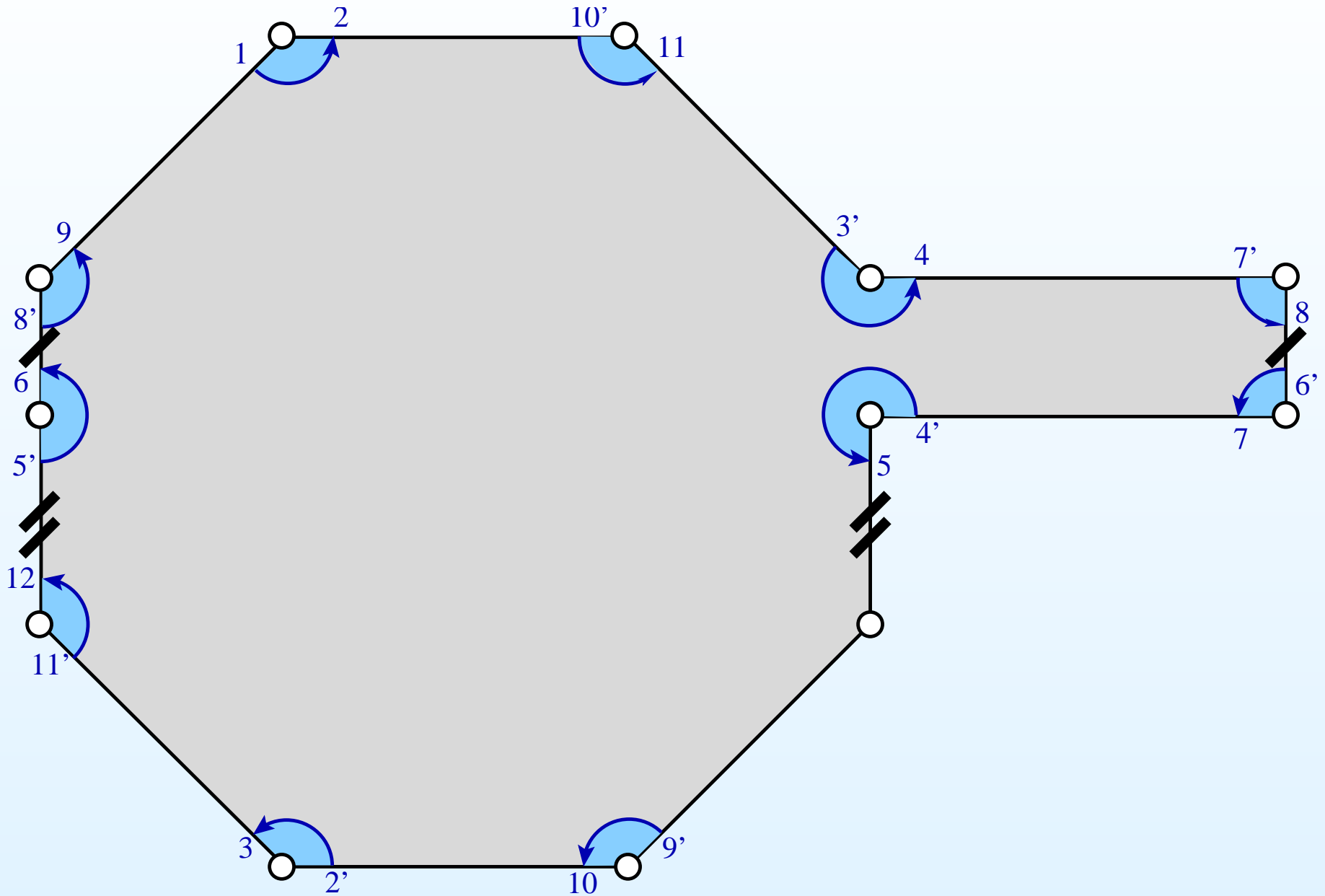

- Proof that the following flat surface belongs to the stratum $\mathcal{H}(4)$.

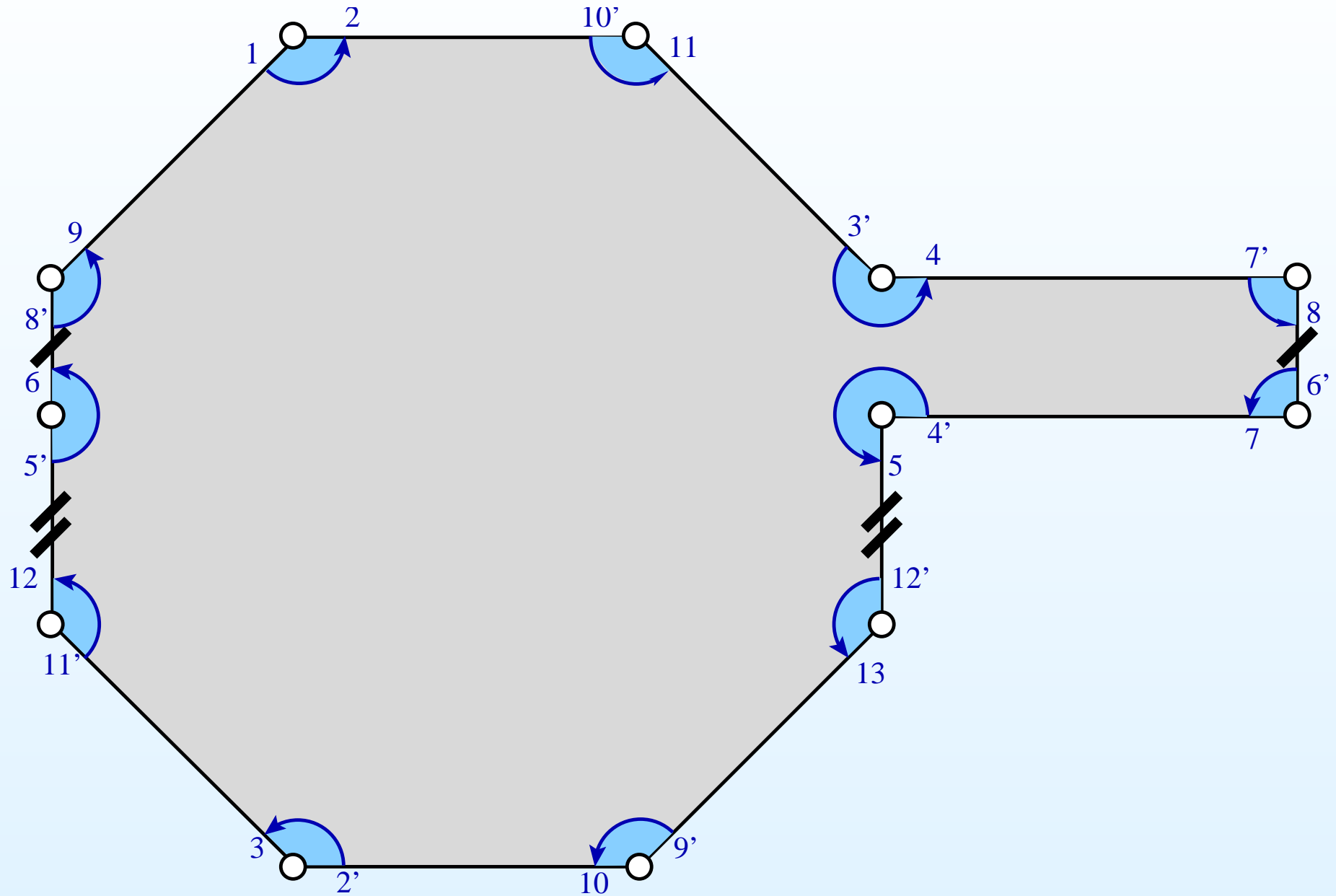

- Construction of a canonical basis of cycles.

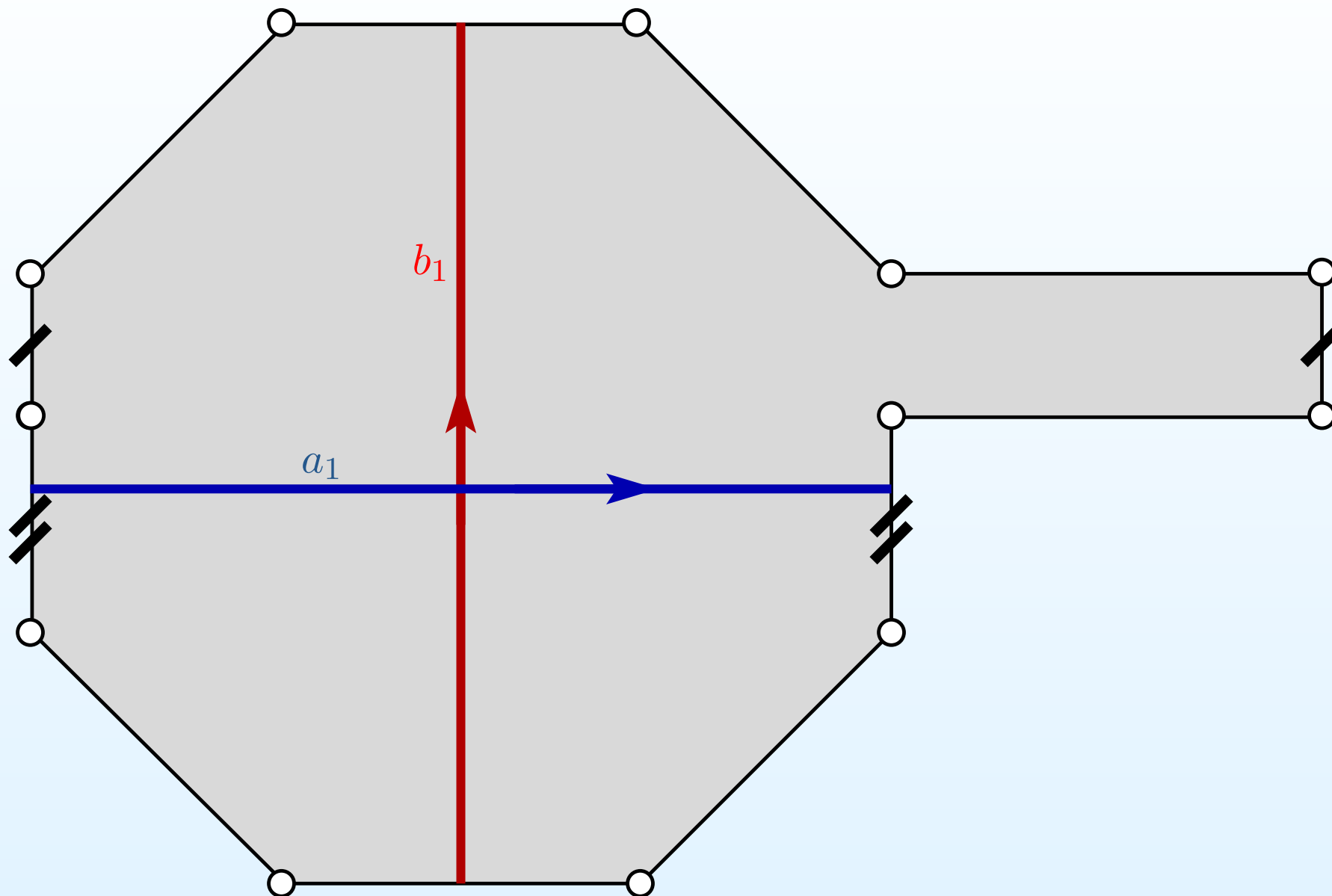

- Construction of a canonical basis of cycles.

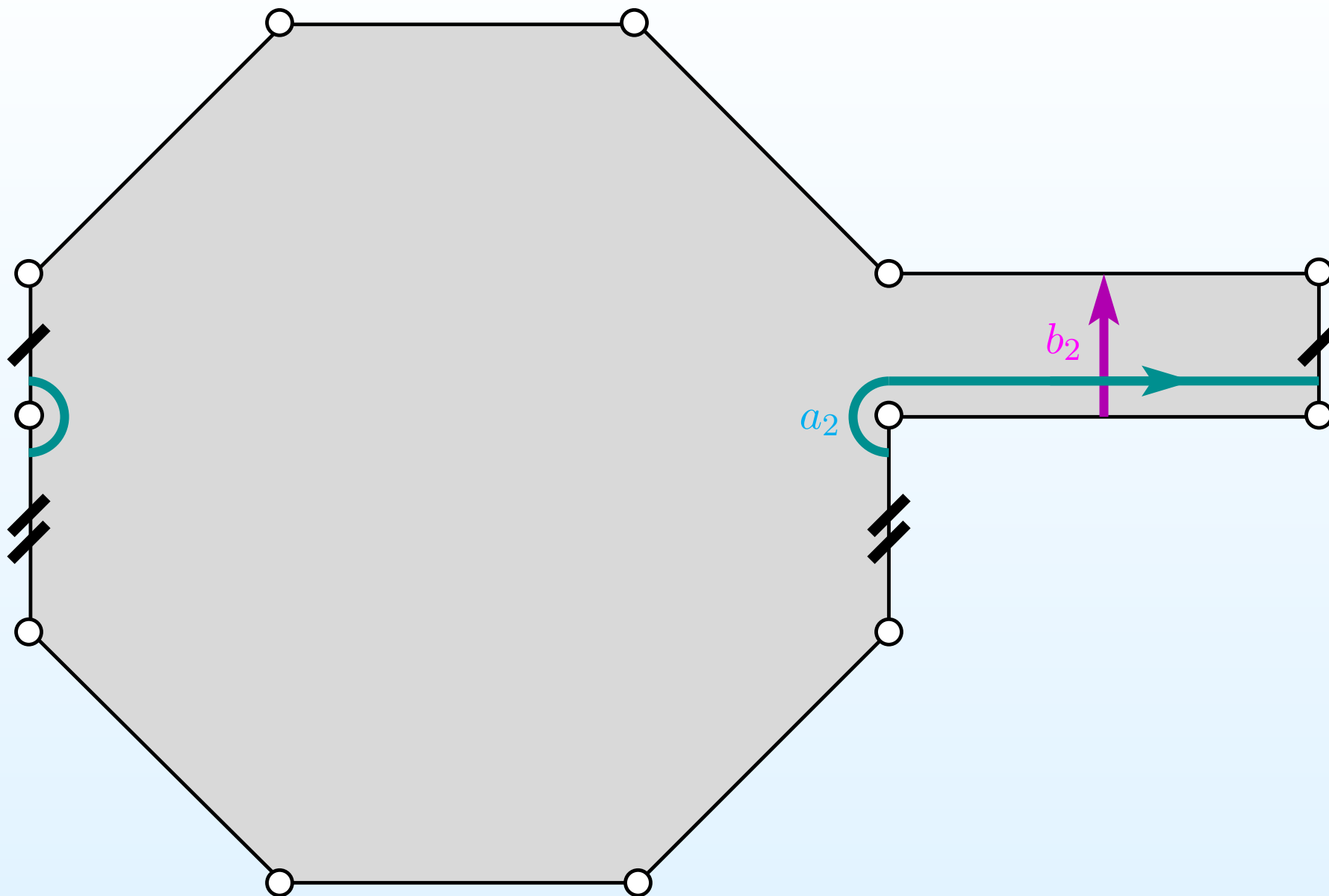

- Construction of a canonical basis of cycles.

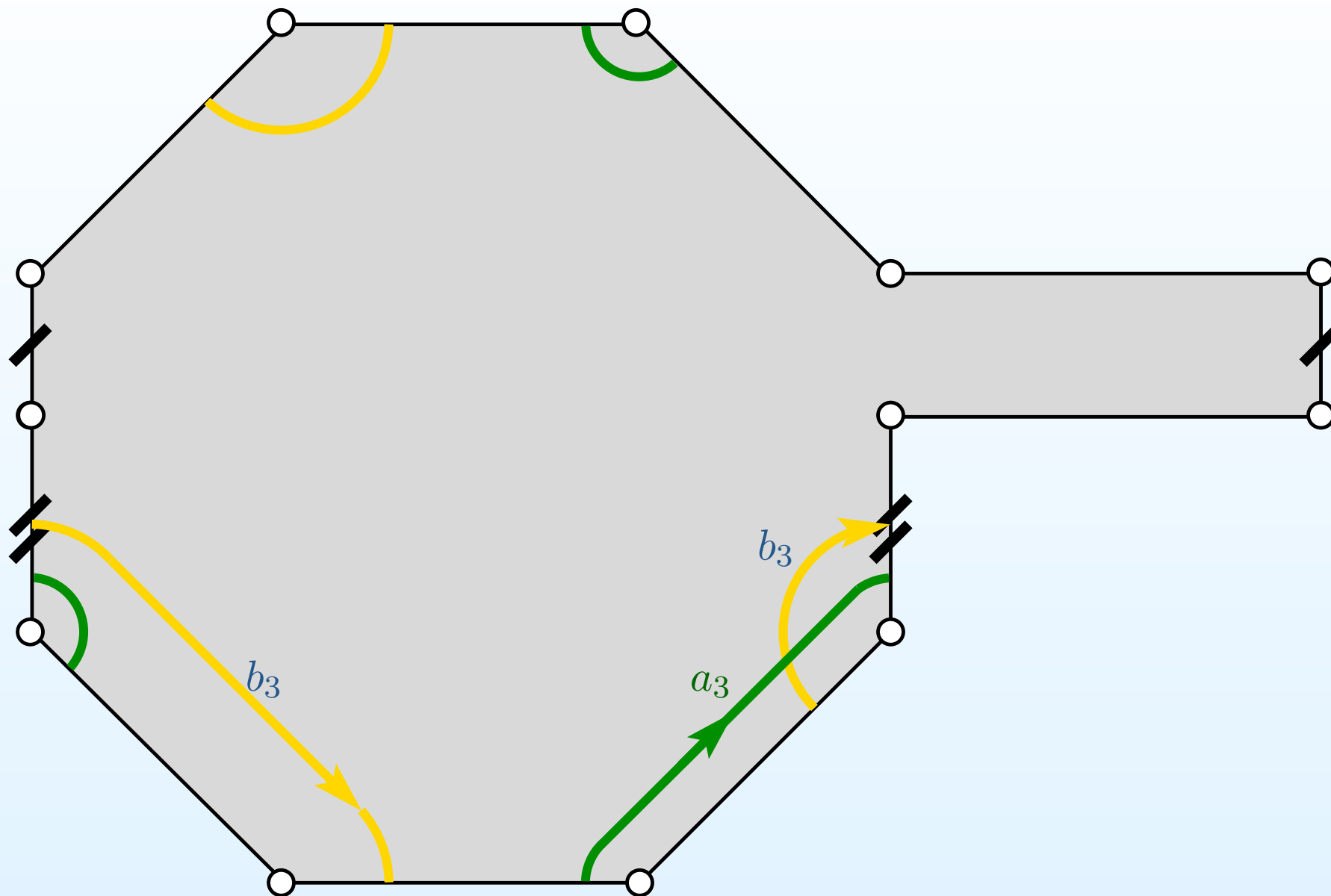

- Construction of a canonical basis of cycles.

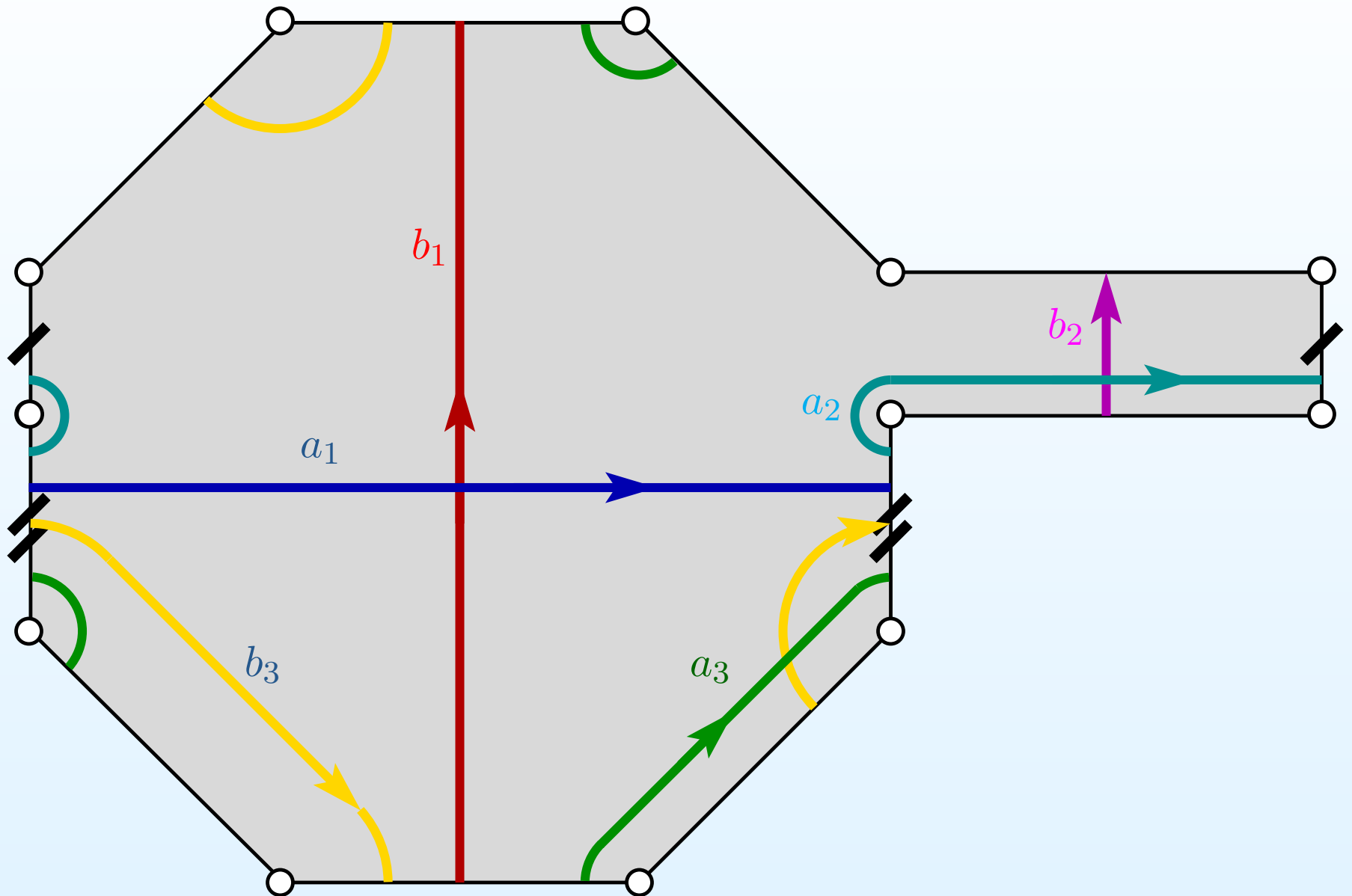

- Evaluation of the parity of a spin-structure.

$$\begin{aligned} \text{ind}(a_1) &= 0; & \text{ind}(b_1) &= 0; \\ \text{ind}(a_2) &= -1; & \text{ind}(b_2) &= 0; \\ \text{ind}(a_3) &= -1; & \text{ind}(b_3) &= -1. \end{aligned}$$

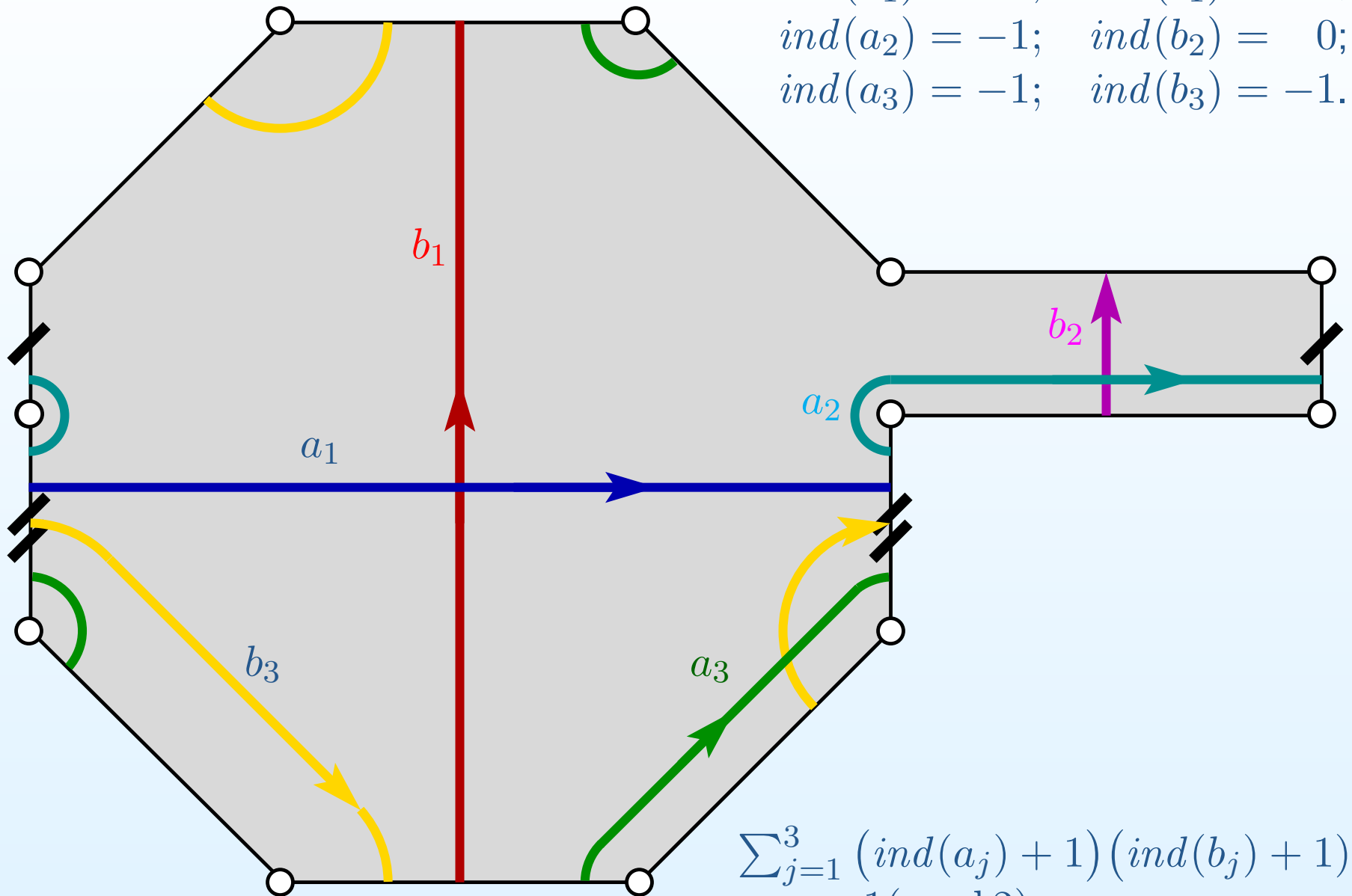

$$\sum_{j=1}^3 (\text{ind}(a_j) + 1) (\text{ind}(b_j) + 1) = 1 \pmod{2}$$

Spin-structure of minimal hyperelliptic components

Theorem (M. Kontsevich, A. Zorich, 2003) *Parity of the spin structure determined by an Abelian differential from the hyperelliptic component $\mathcal{H}^{hyp}(2g - 2)$ equals*

$$\varphi(\mathcal{H}^{hyp}(2g - 2)) \equiv \left[\frac{g + 1}{2} \right] \pmod{2}.$$

In particular,

$$\varphi(\mathcal{H}^{hyp}(0)) = 1 \quad \varphi(\mathcal{H}^{hyp}(2)) = 1 \quad \varphi(\mathcal{H}^{hyp}(4)) = 0$$

and we conclude that the surface constructed above lives in $\mathcal{H}^{odd}(4)$.

- Find the hyperelliptic involution of the remaining surface in geometric terms. Find the Weierstrass points (the fixed points of the hyperelliptic involution). Check that there are $2g + 2 = 2 \cdot 3 + 2 = 8$ such points.

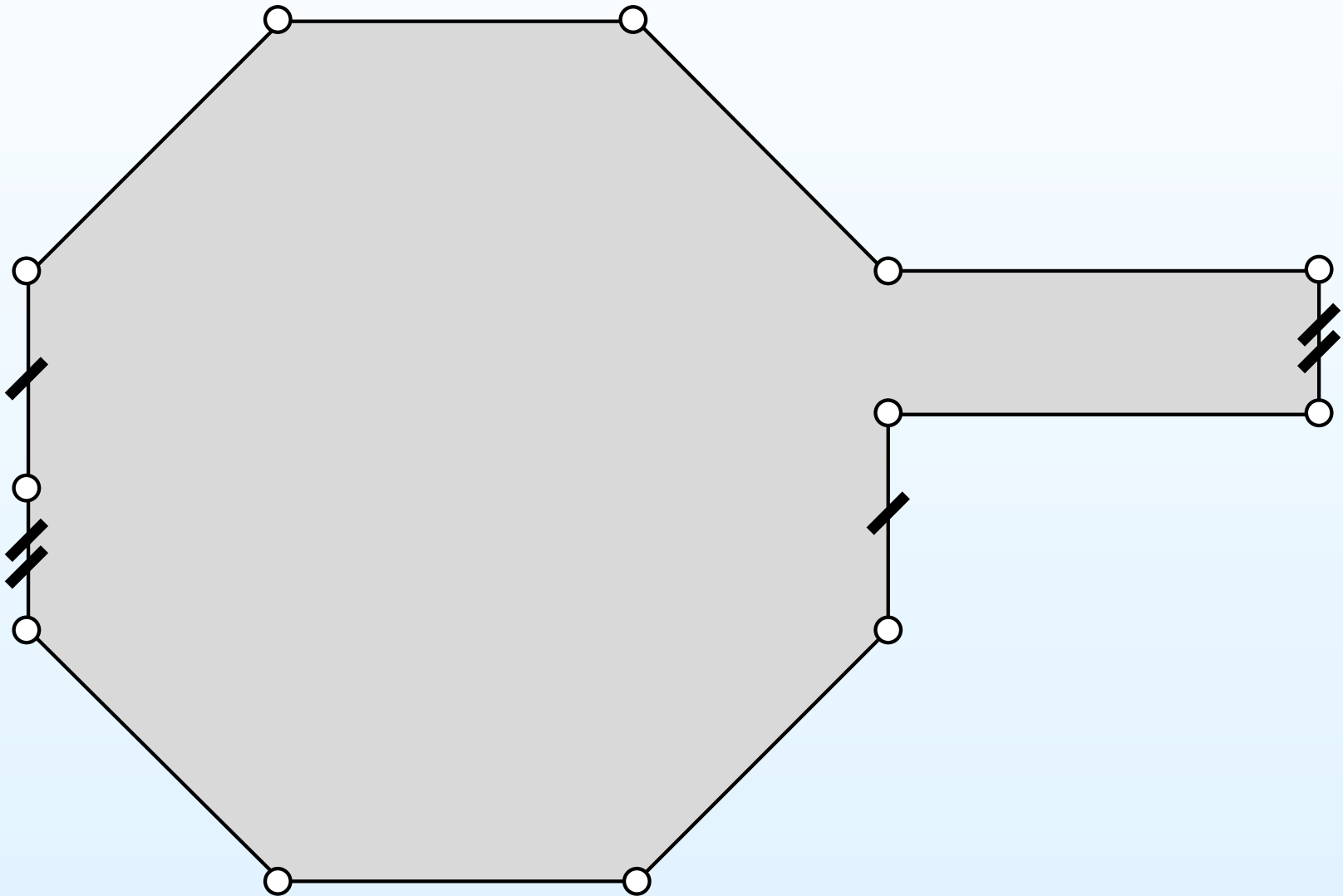

- Find the hyperelliptic involution of the remaining surface in geometric terms. Find the Weierstrass points (the fixed points of the hyperelliptic involution). Check that there are $2g + 2 = 2 \cdot 3 + 2 = 8$ such points.

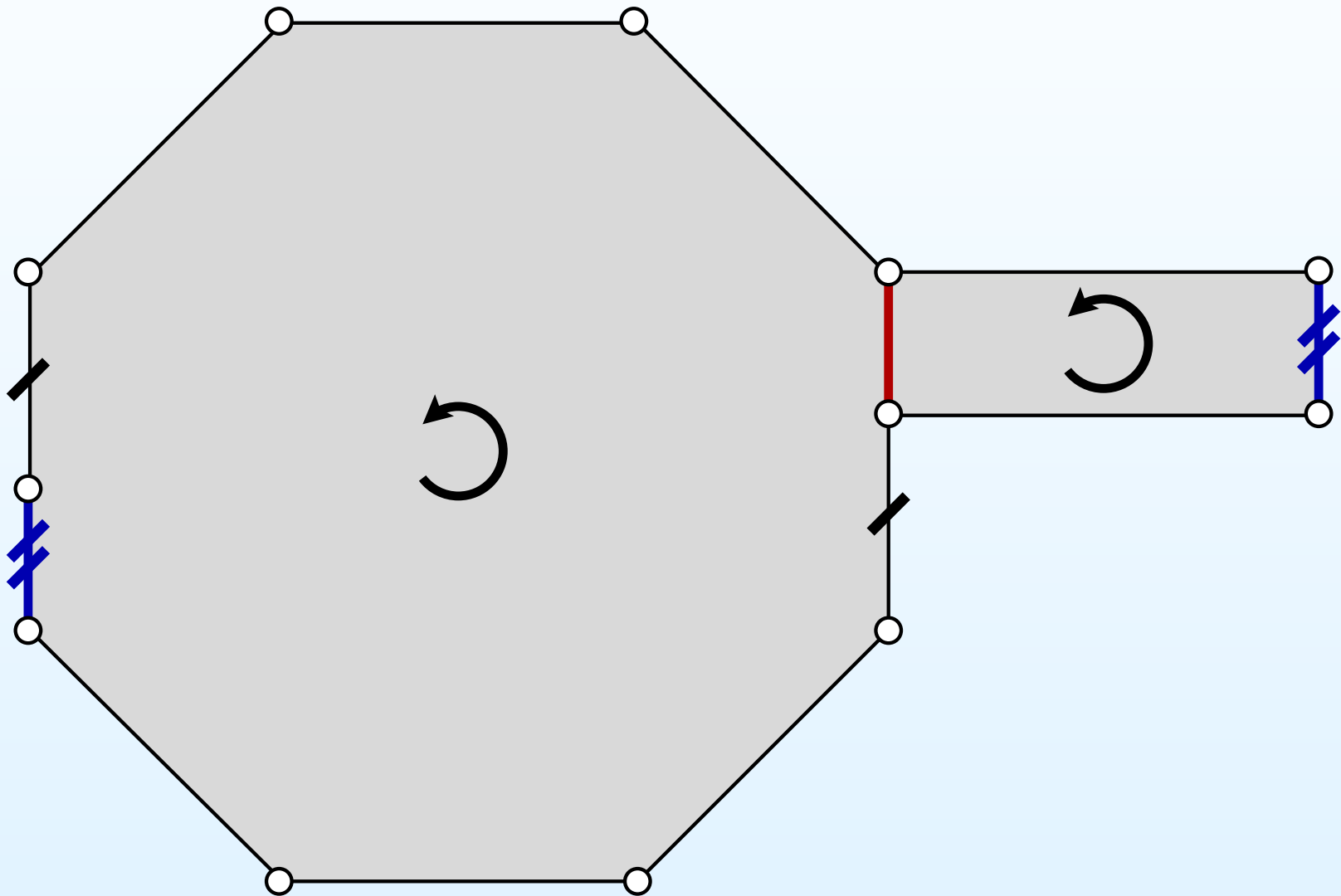

- Find the hyperelliptic involution of the remaining surface in geometric terms. Find the Weierstrass points (the fixed points of the hyperelliptic involution). Check that there are $2g + 2 = 2 \cdot 3 + 2 = 8$ such points.

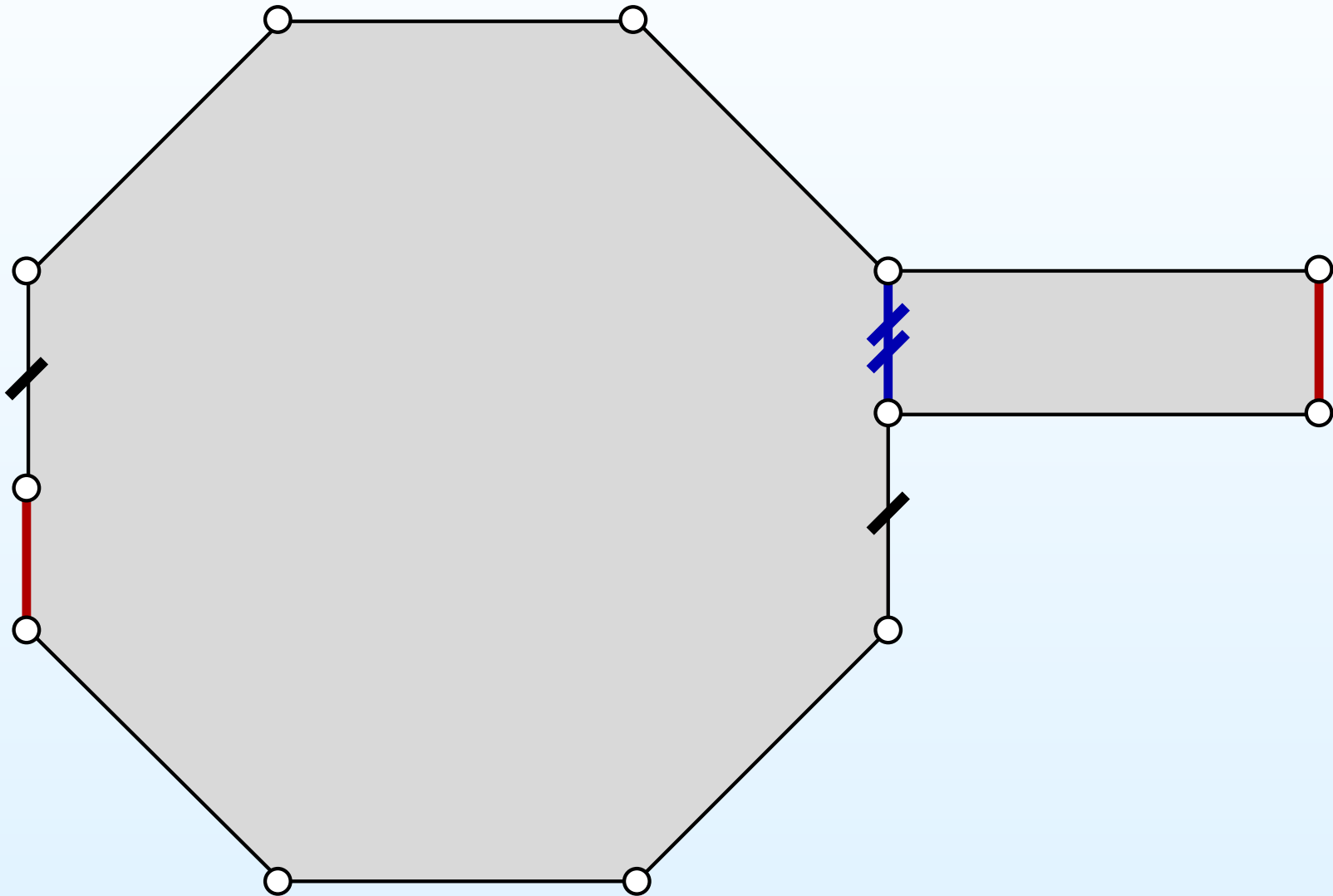

- Find the hyperelliptic involution of the remaining surface in geometric terms. Find the Weierstrass points (the fixed points of the hyperelliptic involution). Check that there are $2g + 2 = 2 \cdot 3 + 2 = 8$ such points.

