

Geometry and dynamics in moduli spaces

Complement to homework assignment 2

Anton Zorich
Université Paris Cité

April 7, 2026

Components of the minimal stratum in genus three

- Check that the following two flat surfaces belong to the stratum $\mathcal{H}(4)$.

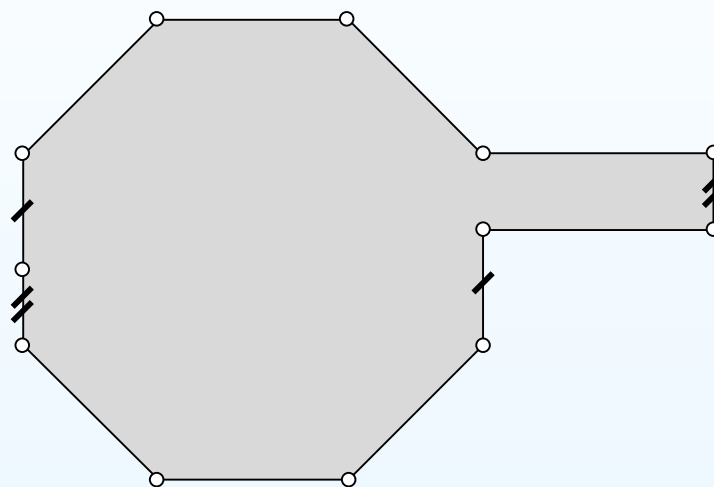
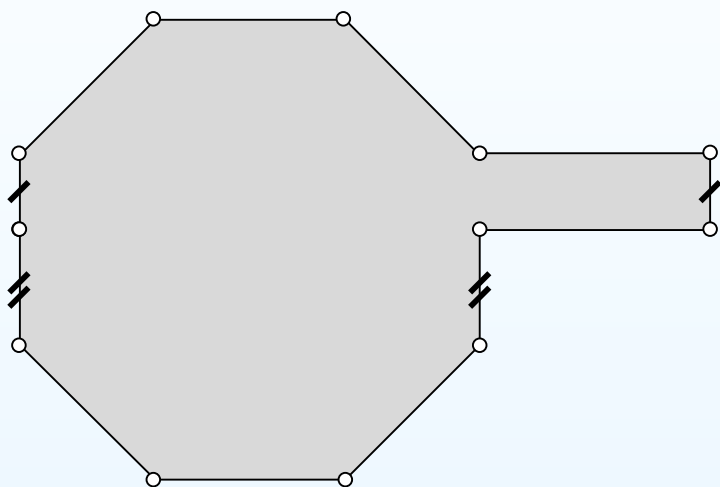

- Compute the parity of the spin structure for these surfaces (and notice that it is not the same).
- Determine which of the two surfaces is hyperelliptic.
- Find the hyperelliptic involution of this surface in geometric terms. Find the Weierstrass points (the fixed points of the hyperelliptic involution). Check that there are $2g + 2$ such points.

Reconstruct a surface from interval exchange transformation

V. Arnold writes in his comment: *“Kontsevich has recently attempted to claim that the interval exchange of three segments is always rotation equivalent. Problem 2002-8 requires the study of the frequency of the counterexamples to this “equivalence” (the existence of such counterexamples being, of course, known to me in the 1950s while I was inventing the segments interchange problem.)”*

Problem.

1. Suppose that a transitive flow on a translation surface S induces an interval exchange transformation with a permutation $(3, 2, 1)$ as the first return map to some transverse interval. What is the genus of S and what is the number and types of conical singularities of the flat metric on S ?
2. Same question for the permutation $(4, 3, 2, 1)$.
3. Suggest a geometric interpretation of the claim of Kontsevich which Arnold did not understand.
4. Suggest a geometric interpretation of the claim by Arnold that an interval exchange transformation with permutation $(2, 1)$ is “rotation equivalent”.