

International Conference on Special Functions & Applications
Amal Jyothi College on Engineering, Kanjirapalli, Kottayam (Kerala).

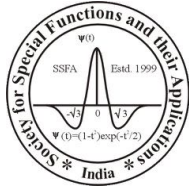

Linear recurrence sequences: an introduction

Michel Waldschmidt

Institut de Mathématiques de Jussieu — Sorbonne Université

<http://www.math.jussieu.fr/~michel.waldschmidt/>

Abstract

Linear recurrence sequences are ubiquitous. They occur in biology, economics, computer science (analysis of algorithms), digital signal processing. We give a survey of this subject, together with connections with linear combinations of powers, with powers of matrices and with linear differential equations.

Applications of linear recurrence sequences

Combinatorics
Elimination
Symmetric functions
Hypergeometric series
Language
Communication, shift registers
Finite difference equations
Logic
Approximation
Pseudo-random sequences

Applications of linear recurrence sequences

- Biology (Integrodifference equations, spatial ecology).
- Computer science (analysis of algorithms).
- Digital signal processing (infinite impulse response (IIR) digital filters).
- Economics (time series analysis).

https://en.wikipedia.org/wiki/Recurrence_relation

How many ancestors do we have?



Geometric series $u_0 = 1, u_{n+1} = 2u_n$

How many ancestors do we have?
 Sequence: 1, 2, 4, 8, 16 ...

Bees genealogy

Male honeybees are born from unfertilized eggs. Female honeybees are born from fertilized eggs. Therefore males have only a mother, but females have both a mother and a father.

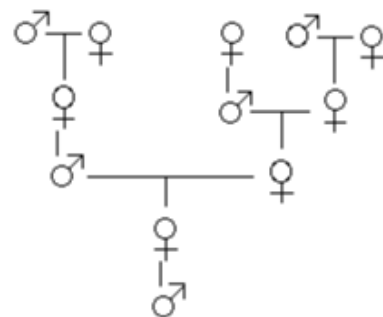

Genealogy of a male bee (bottom – up)

Number of bees :

1, 1, 2, 3, 5...

Number of females :

0, 1, 1, 2, 3...

Rule :

$$u_{n+2} = u_{n+1} + u_n.$$

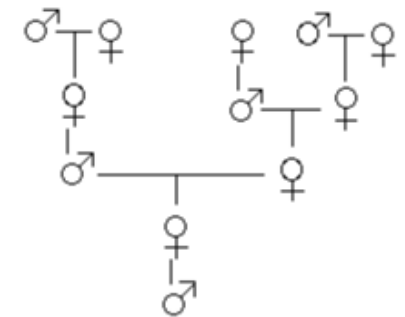

Bees genealogy $u_1 = 1, u_2 = 1, u_{n+2} = u_{n+1} + u_n$

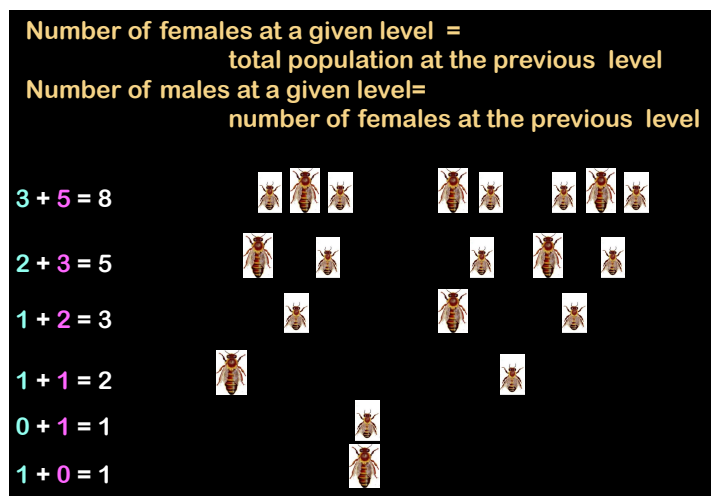

The Lamé Series



Gabriel Lamé
1795 – 1870



Edouard Lucas
1842 - 1891

In 1844 the sequence

$$0, 1, 1, 2, 3, 5, 8, 13, 21, 34, 55, 89, 144, 233, \dots$$

was referred to as the Lamé series, because Gabriel Lamé used it to give an upper bound for the number of steps in the Euclidean algorithm for the gcd.

On a trip to Italy in 1876 Edouard Lucas found them in a copy of the Liber Abbaci of Leonardo da Pisa.

Leonardo Pisano (Fibonacci)

Fibonacci sequence $(F_n)_{n \geq 0}$,

$$0, 1, 1, 2, 3, 5, 8, 13, 21,$$

$$34, 55, 89, 144, 233, \dots$$

is defined by

$$F_0 = 0, F_1 = 1,$$

$$F_{n+2} = F_{n+1} + F_n \text{ for } n \geq 0.$$

<http://oeis.org/A000045>

Leonardo Pisano (Fibonacci)
(1170–1250)



Fibonacci rabbits

Fibonacci considered the growth of a rabbit population.

A newly born pair of rabbits, a male and a female, are put in a field. Rabbits are able to mate at the age of one month so that at the end of its second month a female can produce another pair of rabbits; rabbits never die and a mating pair always produces

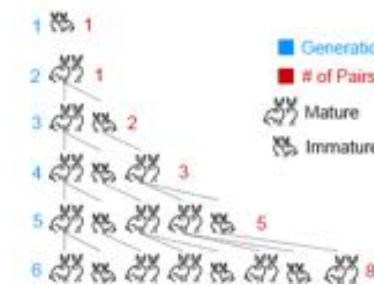

one new pair (one male, one female) every month from the second month on. The puzzle that Fibonacci posed was : how many pairs will there be in one year ?

Answer : $F_{12} = 144$.

Fibonacci's rabbits

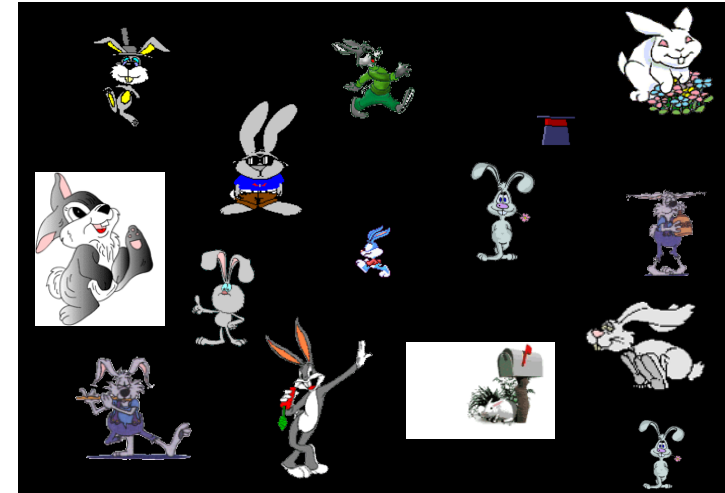
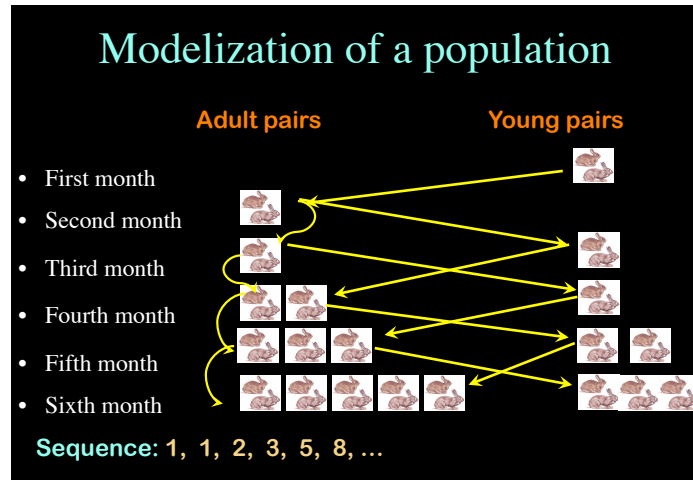

Modelization of a population of mice

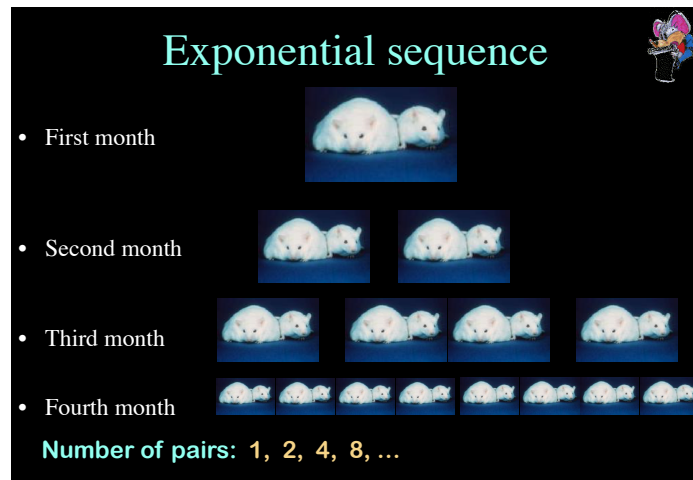

Is-it a realistic model ?

The genealogy of the ancestors of a human being is not a mathematical tree :
30 generations would give 2^{30} ancestors, more than a billion people, three to four times more than the total population on earth one thousand years ago.

Even worse for the genealogy of bees :

In every bee hive there is one female queen bee which lays all the eggs. If an egg is not fertilised it eventually hatches into a male bee, called a drone. If an egg is fertilised by a male bee, then the egg produces a female worker bee, which doesn't lay any eggs herself.

Alfred Lotka : arctic trees

In cold countries, each branch of some trees gives rise to another one after the second year of existence only.



Fibonacci squares

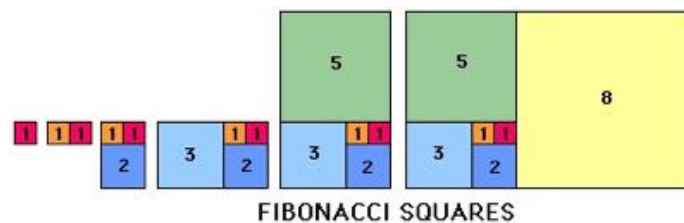

<http://mathforum.org/dr.math/faq/faq.golden.ratio.html>

Geometric construction of the Fibonacci sequence

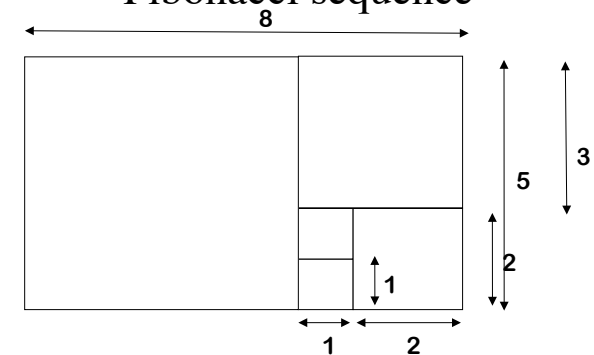

Golden rectangle

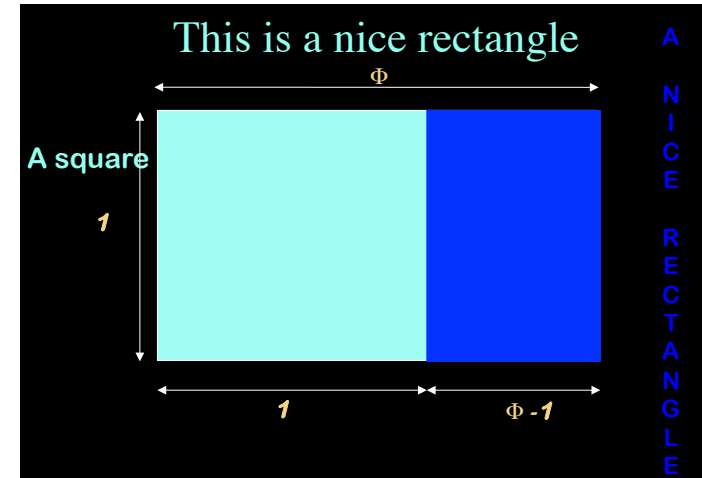
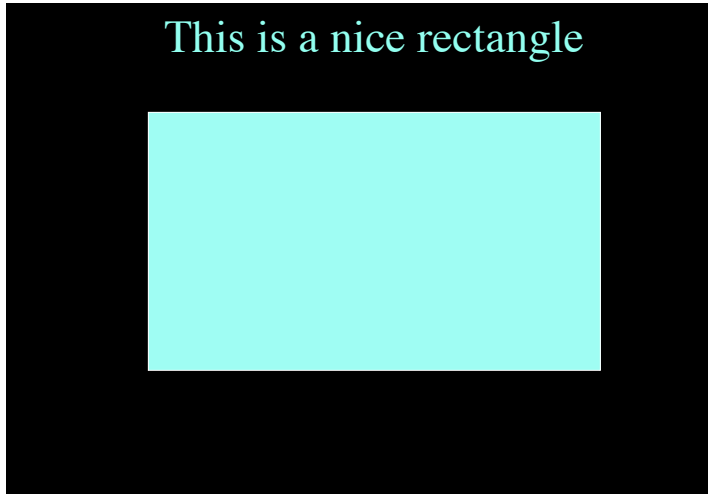

$$\frac{\Phi}{1} = \frac{1}{\Phi - 1}$$

Fibonacci numbers in nature

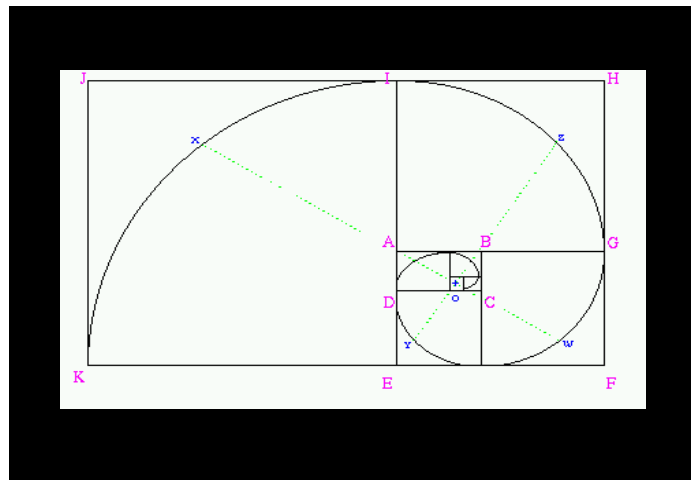

Ammonite (Nautilus shape)

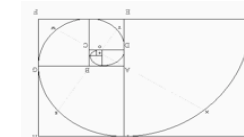
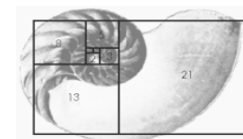
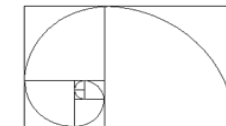

Phyllotaxy



- Study of the position of leaves on a stem and the reason for them
- Number of petals of flowers: daisies, sunflowers, aster, chicory, asteraceae,...
- Spiral pattern to permit optimal exposure to sunlight
- Pine-cone, pineapple, Romanesco cawiflower, cactus

Leaf arrangements

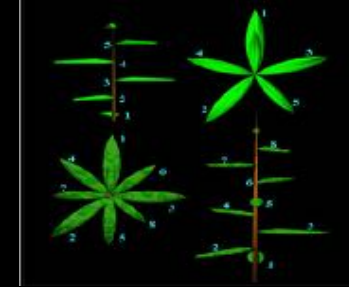

- Université de Nice,
Laboratoire Environnement Marin Littoral,
Equipe d'Accueil "Gestion de la
Biodiversité"



<http://www.unice.fr/LEML/coursJDV/tp/tp3.htm>

Phyllotaxy

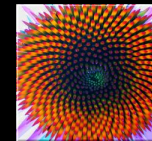

Phyllotaxy

- J. Kepler (1611) uses the Fibonacci sequence in his study of the dodecahedron and the icosaedron, and then of the symmetry of order 5 of the flowers.
- Stéphane Douady and Yves Couder *Les spirales végétales* La Recherche 250 (Jan. 1993) vol. **24**.

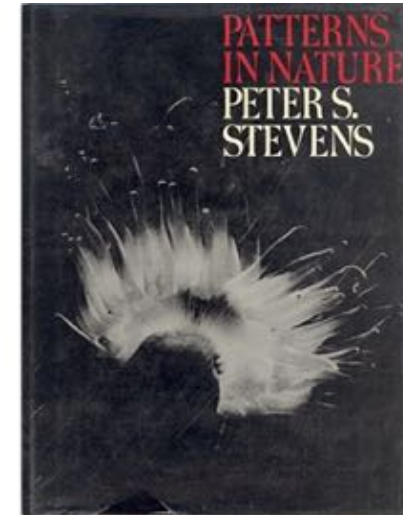

ON GROWTH AND FORM

The Complete Revised Edition



D'Arcy Wentworth Thompson

Reflections of a ray of light

Consider three parallel sheets of glass and a ray of light which crosses the first sheet. Each time it touches one of the sheets, it can cross it or reflect on it.

Denote by p_n the number of different paths with the ray going out of the system after n reflections.

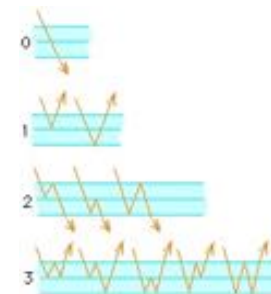

$$p_0 = 1,$$

$$p_1 = 2,$$

$$p_2 = 3,$$

$$p_3 = 5.$$

In general, $p_n = F_{n+2}$.

Levels of energy of an electron of an atom of hydrogen

An atom of hydrogen can have three levels of energy, 0 at the ground level when it does not move, 1 or 2. At each step, it **alternatively** gains and loses some level of energy, either 1 or 2, without going sub 0 nor above 2. Let ℓ_n be the number of different possible scenarios for this electron after n steps.

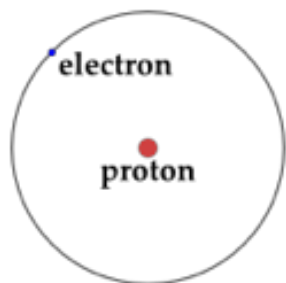

In general, $\ell_n = F_{n+2}$.

We have $\ell_0 = 1$ (initial state level 0)
 $\ell_1 = 2$: state 1 or 2, scenarios (ending with gain) 01 or 02.
 $\ell_2 = 3$: scenarios (ending with loss) 010, 021 or 020.
 $\ell_3 = 5$: scenarios (ending with gain) 0101, 0102, 0212, 0201 or 0202.

Rhythmic patterns

The **Fibonacci** sequence appears in Indian mathematics, in connection with Sanskrit prosody. Several Indian scholars, **Pingala** (200 BC), **Virahanka** (c. 700 AD), **Gopāla** (c. 1135), and the Jain scholar **Hemachandra** (c. 1150). studied rhythmic patterns that are formed by concatenating one beat notes • and double beat notes ■■.

one-beat note • : short syllable (ti in **Morse** Alphabet)

double beat note ■■ : long syllable (ta ta in **Morse**)

1 beat, 1 pattern : •

2 beats, 2 patterns : •• and ■■

3 beats, 3 patterns : •••, •■■ and ■■■

4 beats, 5 patterns :

••••, ■■■•, •■■■, ••■■, ■■■■

n beats, F_{n+1} patterns.

Fibonacci sequence and the Golden ratio

For $n \geq 0$, the **Fibonacci** number F_n is the nearest integer to

$$\frac{1}{\sqrt{5}}\Phi^n,$$

where Φ is the **Golden Ratio** : <http://oeis.org/A001622>

$$\Phi = \frac{1 + \sqrt{5}}{2} = \lim_{n \rightarrow \infty} \frac{F_{n+1}}{F_n} = 1.6180339887499\dots$$

which satisfies

$$\Phi = 1 + \frac{1}{\Phi}.$$

Binet's formula

For $n \geq 0$,

$$F_n = \frac{\Phi^n - (-\Phi)^{-n}}{\sqrt{5}}$$

$$= \frac{(1 + \sqrt{5})^n - (1 - \sqrt{5})^n}{2^n \sqrt{5}},$$

Jacques Philippe Marie Binet (1843)



$$\Phi = \frac{1 + \sqrt{5}}{2}, \quad -\Phi^{-1} = \frac{1 - \sqrt{5}}{2},$$

$$X^2 - X - 1 = (X - \Phi)(X + \Phi^{-1}).$$

The so-called Binet Formula

Formula of A. De Moivre (1718, 1730), Daniel Bernoulli (1726), L. Euler (1728, 1765), J.P.M. Binet (1843) : for $n \geq 0$,

$$F_n = \frac{1}{\sqrt{5}} \left(\frac{1 + \sqrt{5}}{2} \right)^n - \frac{1}{\sqrt{5}} \left(\frac{1 - \sqrt{5}}{2} \right)^n.$$

Abraham de Moivre
(1667–1754)



Daniel Bernoulli
(1700–1782)



Leonhard Euler
(1707–1783)



Jacques P.M. Binet
(1786–1856)



Generating series

A single series encodes all the Fibonacci sequence :

$$\sum_{n \geq 0} F_n X^n = X + X^2 + 2X^3 + 3X^4 + 5X^5 + \dots + F_n X^n + \dots$$

Fact : this series is the Taylor expansion of a rational fraction :

$$\sum_{n \geq 0} F_n X^n = \frac{X}{1 - X - X^2}.$$

Proof : the product

$$(X + X^2 + 2X^3 + 3X^4 + 5X^5 + 8X^6 + \dots)(1 - X - X^2)$$

is a telescoping series

$$\begin{aligned} & X + X^2 + 2X^3 + 3X^4 + 5X^5 + 8X^6 + \dots \\ & - X^2 - X^3 - 2X^4 - 3X^5 - 5X^6 - \dots \\ & - X^3 - X^4 - 2X^5 - 3X^6 - \dots \\ & = X. \end{aligned}$$

Generating series of the Fibonacci sequence

Remark. The denominator $1 - X - X^2$ in the right hand side of

$$X + X^2 + 2X^3 + 3X^4 + \dots + F_n X^n + \dots = \frac{X}{1 - X - X^2}$$

is $X^2 f(X^{-1})$, where $f(X) = X^2 - X - 1$ is the irreducible polynomial of the Golden ratio Φ .

Homogeneous linear differential equation

Consider the homogeneous linear differential equation

$$y'' - y' - y = 0.$$

If $y = e^{\lambda x}$ is a solution, from $y' = \lambda y$ and $y'' = \lambda^2 y$ we deduce

$$\lambda^2 - \lambda - 1 = 0.$$

The two roots of the polynomial $X^2 - X - 1$ are Φ (the Golden ratio) and Φ' with

$$\Phi' = 1 - \Phi = -\frac{1}{\Phi}.$$

A basis of the space of solutions is given by the two functions $e^{\Phi x}$ and $e^{\Phi' x}$. Since (Binet's formula)

$$\sum_{n \geq 0} F_n \frac{x^n}{n!} = \frac{1}{\sqrt{5}} (e^{\Phi x} - e^{\Phi' x}),$$

this exponential generating series of the Fibonacci sequence is a solution of the differential equation.

Fibonacci and powers of matrices

The Fibonacci linear recurrence relation $F_{n+2} = F_{n+1} + F_n$ for $n \geq 0$ can be written

$$\begin{pmatrix} F_{n+1} \\ F_{n+2} \end{pmatrix} = \begin{pmatrix} 0 & 1 \\ 1 & 1 \end{pmatrix} \begin{pmatrix} F_n \\ F_{n+1} \end{pmatrix}.$$

By induction one deduces, for $n \geq 0$,

$$\begin{pmatrix} F_n \\ F_{n+1} \end{pmatrix} = \begin{pmatrix} 0 & 1 \\ 1 & 1 \end{pmatrix}^n \begin{pmatrix} 0 \\ 1 \end{pmatrix}.$$

An equivalent formula is, for $n \geq 1$,

$$\begin{pmatrix} 0 & 1 \\ 1 & 1 \end{pmatrix}^n = \begin{pmatrix} F_{n-1} & F_n \\ F_n & F_{n+1} \end{pmatrix}.$$

Fibonacci sequence and the Golden ratio (continued)

For $n \geq 1$, $\Phi^n \in \mathbb{Z}[\Phi] = \mathbb{Z} + \mathbb{Z}\Phi$ is a linear combination of 1 and Φ with integer coefficients, namely

$$\Phi^n = F_{n-1} + F_n \Phi.$$

Characteristic polynomial

The characteristic polynomial of the matrix

$$A = \begin{pmatrix} 0 & 1 \\ 1 & 1 \end{pmatrix}$$

is

$$\det(XI - A) = \det \begin{pmatrix} X & -1 \\ -1 & X-1 \end{pmatrix} = X^2 - X - 1,$$

which is the irreducible polynomial of the Golden ratio Φ .

Fibonacci sequence and Hilbert's 10th problem

Yuri Matiyasevich (1970) showed that there is a polynomial P in n, m , and a number of other variables x, y, z, \dots having the property that $n = F_{2m}$ iff there exist integers x, y, z, \dots such that $P(n, m, x, y, z, \dots) = 0$.

This completed the proof of the impossibility of the tenth of Hilbert's problems (*does there exist a general method for solving Diophantine equations?*) thanks to the previous work of Hilary Putnam, Julia Robinson and Martin Davis.



The Fibonacci Quarterly

The Fibonacci sequence satisfies a lot of very interesting properties. Four times a year, the *Fibonacci Quarterly* publishes an issue with new properties which have been discovered.

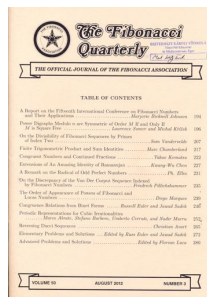

Why are there so many occurrences of Fibonacci numbers and Golden ratio in the nature?

According to Leonid Levin, objects with a small algorithmic Kolmogorov complexity (generated by a short program) occur more often than others.



Another example is given by Sierpinski triangles.

Reference : J-P. Delahaye.
<http://cristal.univ-lille.fr/~jdelahay/pls/>

Lucas sequence

<http://oeis.org/000032>

The Lucas sequence $(L_n)_{n \geq 0}$ satisfies the same recurrence relation as the Fibonacci sequence, namely

$$L_{n+2} = L_{n+1} + L_n \quad \text{for } n \geq 0,$$

only the initial values are different :

$$L_0 = 2, L_1 = 1.$$

The sequence of Lucas numbers starts with

2, 1, 3, 4, 7, 11, 18, 29, 47, 76, 123, 199, 322, ...

A closed form involving the Golden ratio Φ is

$$L_n = \Phi^n + (-\Phi)^{-n},$$

from which it follows that for $n \geq 2$, L_n is the nearest integer to Φ^n .

François Édouard Anatole Lucas (1842 - 1891)

Edouard Lucas is best known for his results in number theory. He studied the Fibonacci sequence and devised the test for Mersenne primes still used today.



<http://www-history.mcs.st-andrews.ac.uk/history/Mathematicians/Lucas.html>

Generating series of the Lucas sequence

The generating series of the Lucas sequence

$$\sum_{n \geq 0} L_n X^n = 2 + X + 3X^2 + 4X^3 + \dots + L_n X^n + \dots$$

is nothing else than

$$\frac{2 - X}{1 - X - X^2}.$$

Homogeneous linear differential equation

We have seen that

$$\sum_{n \geq 0} F_n \frac{x^n}{n!} = \frac{1}{\sqrt{5}} (e^{\Phi x} - e^{\Phi' x})$$

is a solution of the homogeneous linear differential equation

$$y'' - y' - y = 0.$$

Since

$$\sum_{n \geq 0} L_n \frac{x^n}{n!} = e^{\Phi x} + e^{\Phi' x},$$

we deduce that a basis of the space of solutions is given by the two generating series

$$\sum_{n \geq 0} F_n \frac{x^n}{n!} \quad \text{and} \quad \sum_{n \geq 0} L_n \frac{x^n}{n!}.$$

The Lucas sequence and power of matrices

From the linear recurrence relation $L_{n+2} = L_{n+1} + L_n$ one deduces, (as we did for the Fibonacci sequence), for $n \geq 0$,

$$\begin{pmatrix} L_{n+1} \\ L_{n+2} \end{pmatrix} = \begin{pmatrix} 0 & 1 \\ 1 & 1 \end{pmatrix} \begin{pmatrix} L_n \\ L_{n+1} \end{pmatrix},$$

hence

$$\begin{pmatrix} L_n \\ L_{n+1} \end{pmatrix} = \begin{pmatrix} 0 & 1 \\ 1 & 1 \end{pmatrix}^n \begin{pmatrix} 2 \\ 1 \end{pmatrix}.$$

Take three of the four sequences

$$(F_n)_{n \geq 0}, (L_n)_{n \geq 0}, (\Phi^n)_{n \geq 0}, ((-\Phi)^{-n})_{n \geq 0}.$$

Any one of them can be written as a linear combination of the two others.

Perrin sequence

<http://oeis.org/A001608>

The Perrin sequence (also called *skiponacci sequence*) is the linear recurrence sequence $(P_n)_{n \geq 0}$ defined by

$$P_{n+3} = P_{n+1} + P_n \quad \text{for } n \geq 0,$$

with the initial conditions

$$P_0 = 3, P_1 = 0, P_2 = 2.$$

It starts with

$$3, 0, 2, 3, 2, 5, 5, 7, 10, 12, 17, 22, 29, 39, 51, 68, \dots$$

François Olivier Raoul Perrin (1841-1910) :

https://en.wikipedia.org/wiki/Perrin_number

Plastic (or silver) constant

<https://oeis.org/A060006>

The ratio of successive terms in the Perrin sequence approaches the plastic number

$$\varrho = 1.324717957244746\dots$$

which is the minimal Pisot–Vijayaraghavan number, real root of

$$x^3 - x - 1.$$

This constant is equal to

$$\varrho = \frac{\sqrt[3]{108 + 12\sqrt{69}} + \sqrt[3]{108 - 12\sqrt{69}}}{6}.$$

Navigation icons and page number 53 / 92

Generating series of the Perrin sequence

The generating series of the Perrin sequence

$$\sum_{n \geq 0} P_n X^n = 3 + 2X^2 + 3X^3 + 2X^4 + \dots + P_n X^n + \dots$$

is nothing else than

$$\frac{3 - X^2}{1 - X^2 - X^3}.$$

The denominator $1 - X^2 - X^3$ is $X^3 f(X^{-1})$ where $f(X) = X^3 - X - 1$ is the irreducible polynomial of ϱ .

Navigation icons and page number 55 / 92

Perrin sequence and the plastic constant

Decompose the polynomial $X^3 - X - 1$ into irreducible factors over \mathbb{C}

$$X^3 - X - 1 = (X - \varrho)(X - \rho)(X - \bar{\rho})$$

and over \mathbb{R}

$$X^3 - X - 1 = (X - \varrho)(X^2 + \varrho X + \varrho^{-1}).$$

Hence ρ and $\bar{\rho}$ are the roots of $X^2 + \varrho X + \varrho^{-1}$. Then, for $n \geq 0$,

$$P_n = \varrho^n + \rho^n + \bar{\rho}^n.$$

It follows that, for $n \geq 0$, P_n is the nearest integer to ϱ^n .

Navigation icons and page number 54 / 92

Exponential generating series of the Perrin sequence

The power series

$$y(x) = \sum_{n \geq 0} P_n \frac{x^n}{n!}$$

is the solution of the differential equation

$$y''' - y' - y = 0$$

with the initial conditions $y(0) = 3$, $y'(0) = 0$, $y''(0) = 2$.

Navigation icons and page number 56 / 92

Perrin sequence and power of matrices

From

$$P_{n+3} = P_{n+1} + P_n$$

we deduce

$$\begin{pmatrix} P_{n+1} \\ P_{n+2} \\ P_{n+3} \end{pmatrix} = \begin{pmatrix} 0 & 1 & 0 \\ 0 & 0 & 1 \\ 1 & 1 & 0 \end{pmatrix} \begin{pmatrix} P_n \\ P_{n+1} \\ P_{n+2} \end{pmatrix}.$$

Hence

$$\begin{pmatrix} P_n \\ P_{n+1} \\ P_{n+2} \end{pmatrix} = \begin{pmatrix} 0 & 1 & 0 \\ 0 & 0 & 1 \\ 1 & 1 & 0 \end{pmatrix}^n \begin{pmatrix} 3 \\ 0 \\ 2 \end{pmatrix}.$$

Characteristic polynomial

The characteristic polynomial of the matrix

$$A = \begin{pmatrix} 0 & 1 & 0 \\ 0 & 0 & 1 \\ 1 & 1 & 0 \end{pmatrix}$$

is

$$\det(XI - A) = \det \begin{pmatrix} X & -1 & 0 \\ 0 & X & -1 \\ -1 & -1 & X \end{pmatrix} = X^3 - X - 1,$$

which is the irreducible polynomial of the plastic constant ρ .

Perrin's remark

1484. [19c] La curieuse proposition d'origine chinoise qui fait l'objet de la question 1401 fournirait, si elle était exacte, un criterium plus pratique que le théorème de Wilson pour vérifier si un nombre donné m est premier ou non; il suffirait de calculer les résidus par rapport à m des termes successifs de la suite récurrente

$$u_n = 3u_{n-1} - 2u_{n-2}$$

avec les valeurs initiales $u_0 = -1$, $u_1 = 0$.

J'ai rencontré une autre suite récurrente qui paraît jouir de la même propriété; c'est celle dont le terme général est

$$v_n = v_{n-1} + v_{n-2}$$

— 77 —

avec les valeurs initiales $v_0 = 3$, $v_1 = 0$, $v_2 = 2$. Il est facile de démontrer que v_n est divisible par n , si n est premier; j'ai vérifié qu'il ne l'est pas dans le cas contraire, jusqu'à des valeurs assez élevées de n ; mais il serait intéressant de savoir ce qu'il en est réellement, d'autant plus que la suite v_n fournit des nombres bien moins rapidement croissants que la suite u_n (pour $n = 17$, par exemple, on trouve $u_n = 131070$, $v_n = 119$), et se prête à des simplifications de calcul lorsque n est un grand nombre.

La même méthode de démonstration, applicable à l'une des suites, le sera sans doute à l'autre, si la propriété énoncée est exacte pour toutes les deux: il ne s'agit que de la découvrir.

R. PERRIN.

R. Perrin *L'intermédiaire des mathématiciens*, Query 1484, v.6, 76–77 (1899).

The website www.Perrin088.org maintained by Richard Turk is devoted to Perrin numbers. See [OEISA113788](https://oeis.org/A113788).

Perrin pseudoprimes

<https://oeis.org/A013998>

If p is prime, then p divides P_p .

The smallest composite n such that n divides P_n is $521^2 = 271441$.

The number P_{271441} has 33 150 decimal digits (the number c which satisfies $10^c = \rho^{271441}$ is $c = 271441(\log \rho)/(\log 10)$).

Also for the composite number $n = 904631 = 7 \times 13 \times 9941$, the number n divides P_n .

Jon Grantham has proved that there are infinitely many Perrin pseudoprimes.

Padovan sequence

<https://oeis.org/A000931>

The Padovan sequence $(p_n)_{n \geq 0}$ satisfies the same recurrence

$$p_{n+3} = p_{n+1} + p_n$$

as the Perrin sequence but has different initial values :

$$p_0 = 1, \quad p_1 = p_2 = 0.$$

It starts with

1, 0, 0, 1, 0, 1, 1, 1, 2, 2, 3, 4, 5, 7, 9, 12, 16, ...

Richard Padovan

<http://mathworld.wolfram.com/LinearRecurrenceEquation.html>

Generating series and power of matrices

$$1 + X^3 + X^5 + \dots + p_n X^n + \dots = \frac{1 - X^2}{1 - X^2 - X^3}.$$

For $n \geq 0$,

$$\begin{pmatrix} p_n \\ p_{n+1} \\ p_{n+2} \end{pmatrix} = \begin{pmatrix} 0 & 1 & 0 \\ 0 & 0 & 1 \\ 1 & 1 & 0 \end{pmatrix}^n \begin{pmatrix} 1 \\ 0 \\ 0 \end{pmatrix}.$$

Padovan triangles

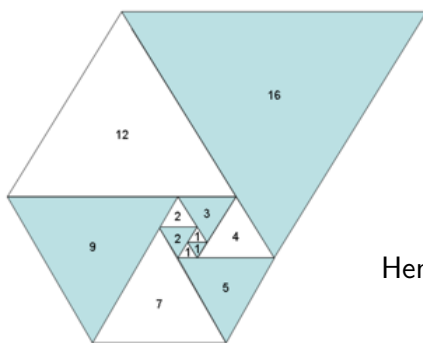

$$p_n = p_{n-2} + p_{n-3}$$

$$p_{n-1} = p_{n-3} + p_{n-4}$$

$$p_{n-2} = p_{n-4} + p_{n-5}$$

Hence

$$p_n - p_{n-1} = p_{n-5}$$

$$p_n = p_{n-1} + p_{n-5}$$

Padovan triangles

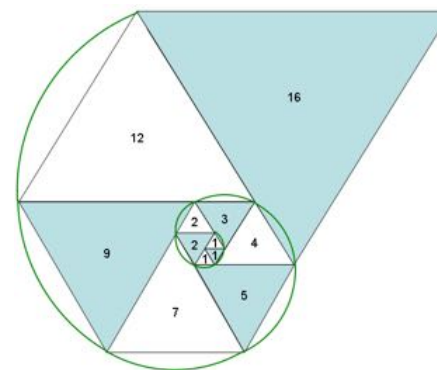

Fibonacci squares vs Padovan triangles

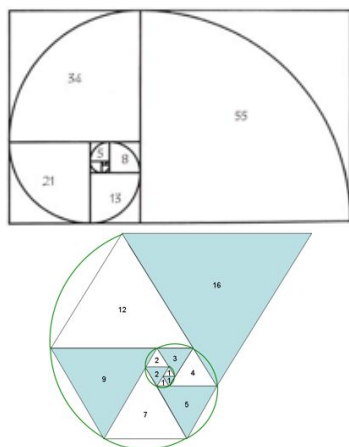

Both are C^1 curve, not C^2

Padovan, Euler, Zagier and Brown

For $n \geq 0$, the number of compositions $\underline{s} = (s_1, \dots, s_k)$ with $s_i \in \{2, 3\}$ and $s_1 + \dots + s_k = n$ is p_{n+3} . This is (an upper bound for) the dimension of the space spanned by the multiple zeta values of weight n of Euler and Zagier.



Narayana sequence

<https://oeis.org/A000930>

Narayana sequence is defined by the recurrence relation

$$C_{n+3} = C_{n+2} + C_n$$

with the initial values $C_0 = 2, C_1 = 3, C_2 = 4$.

It starts with

2, 3, 4, 6, 9, 13, 19, 28, 41, 60, 88, 129, 189, 277, ...

Real root of $x^3 - x^2 - 1$

$$\frac{\sqrt[3]{\frac{29 + 3\sqrt{93}}{2}} + \sqrt[3]{\frac{29 - 3\sqrt{93}}{2}} + 1}{3} = 1.465571231876768 \dots$$

Generating series and power of matrices

$$2 + 3X + 4X^2 + 6X^3 + \dots + C_n X^n + \dots = \frac{2 + X + X^2}{1 - X - X^3}$$

Differential equation : $y''' - y'' - y = 0$;
initial conditions : $y(0) = 2, y'(0) = 3, y''(0) = 4$.

For $n \geq 0$,

$$\begin{pmatrix} C_n \\ C_{n+1} \\ C_{n+2} \end{pmatrix} = \begin{pmatrix} 0 & 1 & 0 \\ 0 & 0 & 1 \\ 1 & 0 & 1 \end{pmatrix}^n \begin{pmatrix} 2 \\ 3 \\ 4 \end{pmatrix}$$

Narayana's cows

Narayana was an Indian mathematician in the 14th century who proposed the following problem :
A cow produces one calf every year. Beginning in its fourth year each calf produces one calf at the beginning of each year.
How many calves are there altogether after, for example, 17 years?

Music :

<http://www.pogus.com/21033.html>

In working this out, Tom Johnson found a way to translate this into a composition called *Narayana's Cows*.

Music : Tom Johnson

Saxophones : Daniel Kientzy



Narayana's cows

<http://www.math.jussieu.fr/~michel.waldschmidt/>

Year	1	2	3	4	5	6	7	8	9	10	11	12	13	14	15	16	17
Original Cow	1	1	1	1	1	1	1	1	1	1	1	1	1	1	1	1	1
Second generation	1	2	3	4	5	6	7	8	9	10	11	12	13	14	15	16	17
Third generation	0	0	0	1	3	6	10	15	21	28	36	45	55	66	78	91	105
Fourth generation	0	0	0	0	0	0	1	4	10	20	35	56	84	120	165	220	286
Fifth generation	0	0	0	0	0	0	0	0	0	1	5	15	35	70	126	210	330
Sixth generation	0	0	0	0	0	0	0	0	0	0	0	0	1	6	21	56	126
Seventh generation	0	0	0	0	0	0	0	0	0	0	0	0	0	0	0	1	7
Total	2	3	4	6	9	13	19	28	41	60	88	129	189	277	406	595	872



Jean-Paul Allouche and Tom Johnson



<http://www.math.jussieu.fr/~jean-paul.allouche/bibliorecente.html>
<http://www.math.jussieu.fr/~allouche/johnson1.pdf>

Cows, music and morphisms

Jean-Paul Allouche and Tom Johnson

- Narayana's Cows and Delayed Morphisms
 In 3èmes Journées d'Informatique Musicale (JIM '96), Ile de Tatihou, Les Cahiers du GREYC (1996 no. 4), pages 2-7, May 1996.

<http://kalvos.org/johnness1.html>

- Finite automata and morphisms in assisted musical composition,
 Journal of New Music Research, no. 24 (1995), 97 – 108.
<http://www.tandfonline.com/doi/abs/10.1080/09298219508570676>
http://web.archive.org/web/19990128092059/www.swets.nl/jnmr/vol24_2.html

Some recent work

Music and the Fibonacci sequence

- Dufay, XV^{ème} siècle
- Roland de Lassus
- Debussy, Bartok, Ravel, Webern
- Stockhausen
- Xenakis
- **Tom Johnson** *Automatic Music for six percussionists*



Christian Ballot
On a family of recurrences that includes the Fibonacci and the Narayana recurrences.
 arXiv:1704.04476 [math.NT]

We survey and prove properties a family of recurrences bears in relation to integer representations, compositions, the Pascal triangle, sums of digits, Nim games and Beatty sequences.

Linear recurrence sequences : examples

$q \geq 1$; initial conditions $u_0 = u_1 = \dots = u_{q-2} = 0, u_{q-1} = 1$.

$$X^q - X^{q-1} - 1 :$$

$q = 1, X - 2$, exponential $u_n = 2^n$

$q = 2, X^2 - X - 1$, Fibonacci $u_n = F_n$

$q = 3, X^3 - X - 1$, Narayana $u_n = C_n$

$$X^q - X^{q-1} - X^{q-2} - \dots - X - 1 :$$

$q = 1, X - 1$, constant sequence $u_n = 1$

$q = 2, X^2 - X - 1$, Fibonacci $u_n = F_n$

$q = 3, X^3 - X^2 - X - 1$, Tribonacci

$$X^q - X - 1 :$$

$q = 2, X^2 - X - 1$, Fibonacci $u_n = F_n$

$q = 3, X^3 - X - 1$, Padovan $u_n = p_n$

Linear recurrence sequences : definitions

A *linear recurrence sequence* is a sequence of numbers $\mathbf{u} = (u_0, u_1, u_2, \dots)$ for which there exist a positive integer d together with numbers a_1, \dots, a_d with $a_d \neq 0$ such that, for $n \geq 0$,

$$(*) \quad u_{n+d} = a_1 u_{n+d-1} + \dots + a_d u_n.$$

Here, a *number* means an element of a field \mathbb{K} of zero characteristic.

Given $\underline{a} = (a_1, \dots, a_d) \in \mathbb{K}^d$, the set of linear recurrence sequences $\mathbf{u} = (u_n)_{n \geq 0}$ satisfying $(*)$ is a \mathbb{K} -vector subspace of dimension d of the space $\mathbb{K}^{\mathbb{N}}$ of all sequences.

The characteristic (or companion) polynomial of the linear recurrence is

$$f(X) = X^d - a_1 X^{d-1} - \dots - a_d.$$

Linear recurrence sequences : examples

- Constant (not zero) sequence : $u_n = u_0$.
Linear recurrence sequence of order 1 : $u_{n+1} = u_n$.
Characteristic polynomial : $f(X) = X - 1$.
Generating series : $\sum_{n \geq 0} X^n = \frac{u_0}{1 - X}$.
Differential equation : $y' = y$.

- Geometric progression : $u_n = u_0 \gamma^n$.
Linear recurrence sequence of order 1 : $u_n = \gamma u_{n-1}$.
Characteristic polynomial : $f(X) = X - \gamma$.
Generating series : $\sum_{n \geq 0} u_0 \gamma^n X^n = \frac{u_0}{1 - \gamma X}$.
Differential equation : $y' = \gamma y$.

Linear recurrence sequences : examples

- The sequence $u_n = n$ is a linear recurrence sequence of order 2 :

$$n + 2 = 2(n + 1) - n.$$

Characteristic polynomial

$$f(X) = X^2 - 2X + 1 = (X - 1)^2.$$

Generating series $\sum_{n \geq 0} nX^n = \frac{1}{1 - 2X + X^2}$.

Differential equation $y'' - 2y' + y = 0$.

Power of matrices :

$$\begin{pmatrix} 0 & 1 \\ -1 & 2 \end{pmatrix}^n = \begin{pmatrix} -n + 1 & n \\ -n & n + 1 \end{pmatrix}.$$

Linear recurrence sequences : examples

- The sequence $u_n = f(n)$, where f is a polynomial of degree d , is a linear recurrence sequence of order $d + 1$.

Proof. The sequences

$$(f(n))_{n \geq 0}, (f(n + 1))_{n \geq 0}, \dots, (f(n + k))_{n \geq 0}$$

are \mathbb{K} -linearly independent in $\mathbb{K}^{\mathbb{N}}$ for $k = d - 1$ and linearly dependent for $k = d$.

A basis of the space of polynomials of degree d is given by the $d + 1$ polynomials

$$f(X), f(X + 1), \dots, f(X + d). \quad \square$$

Exercise : what is the characteristic polynomial of the sequence $u_n = f(n)$?

Generating series of a linear recurrence sequence

A sequence $\mathbf{u} = (u_n)_{n \geq 0}$ satisfies the linear recurrence relation

$$(*) \quad u_{n+d} = a_1 u_{n+d-1} + \dots + a_d u_n \quad \text{for } n \geq 0$$

if and only if its generating series can be written

$$\sum_{n=0}^{\infty} u_n X^n = \frac{B(X)}{A(X)},$$

where

$$A(X) = 1 - a_1 X - \dots - a_d X^d,$$

while $B(X)$ is a polynomial of degree less than d .

Exponential generating series and homogeneous linear differential equations

A sequence $(u_n)_{n \geq 0}$ satisfies the linear recurrence sequence

$$(*) \quad u_{n+d} = a_1 u_{n+d-1} + \cdots + a_d u_n \quad \text{for } n \geq 0$$

if and only if its exponential power series

$$y(x) = \sum_{n \geq 0} u_n \frac{x^n}{n!}$$

satisfies the homogeneous linear differential equations

$$y^{(d)} - a_1 y^{(d-1)} - a_2 y^{(d-2)} - \cdots - a_{d-1} y' - a_d y = 0.$$

Matrix notation for a linear recurrence sequence

The linear recurrence sequence

$$(*) \quad u_{n+d} = a_1 u_{n+d-1} + \cdots + a_d u_n \quad \text{for } n \geq 0$$

can be written

$$\begin{pmatrix} u_{n+1} \\ u_{n+2} \\ \vdots \\ u_{n+d} \end{pmatrix} = \begin{pmatrix} 0 & 1 & 0 & \cdots & 0 \\ 0 & 0 & 1 & \cdots & 0 \\ \vdots & \vdots & \vdots & \ddots & \vdots \\ 0 & 0 & 0 & \cdots & 1 \\ a_d & a_{d-1} & a_{d-2} & \cdots & a_1 \end{pmatrix} \begin{pmatrix} u_n \\ u_{n+1} \\ \vdots \\ u_{n+d-1} \end{pmatrix}.$$

Matrix notation for a linear recurrence sequence

$$U_{n+1} = AU_n$$

with

$$U_n = \begin{pmatrix} u_n \\ u_{n+1} \\ \vdots \\ u_{n+d-1} \end{pmatrix}, \quad A = \begin{pmatrix} 0 & 1 & 0 & \cdots & 0 \\ 0 & 0 & 1 & \cdots & 0 \\ \vdots & \vdots & \vdots & \ddots & \vdots \\ 0 & 0 & 0 & \cdots & 1 \\ a_d & a_{d-1} & a_{d-2} & \cdots & a_1 \end{pmatrix}.$$

Characteristic polynomial of A :

$$\det(I_d X - A) = X^d - a_1 X^{d-1} - \cdots - a_d.$$

By induction

$$U_n = A^n U_0.$$

Powers of matrices

Let $A = (a_{ij})_{1 \leq i, j \leq d} \in \text{GL}_{d \times d}(\mathbb{K})$ be a $d \times d$ matrix with coefficients in \mathbb{K} and nonzero determinant. For $n \geq 0$, let

$$A^n = (a_{ij}^{(n)})_{1 \leq i, j \leq d}.$$

Then each of the d^2 sequences $(a_{ij}^{(n)})_{n \geq 0}$, $(1 \leq i, j \leq d)$ is a linear recurrence sequence.

Conversely :

Given a linear recurrence sequence $\mathbf{u} \in \mathbb{K}^{\mathbb{N}}$, there exist an integer $d \geq 1$ and a matrix $A \in GL_d(\mathbb{K})$ such that, for each $n \geq 0$,

$$u_n = a_{11}^{(n)}.$$

The characteristic polynomial of A is the characteristic polynomial of the linear recurrence sequence.

EVEREST G., VAN DER POORTEN A., SHPARLINSKI I., WARD T. – *Recurrence sequences*, Mathematical Surveys and Monographs (AMS, 2003), volume 104.

Conclusion

The same mathematical object occurs in a different guise :

- Linear recurrence sequences

$$u_{n+d} = a_1 u_{n+d-1} + \cdots + a_d u_n.$$

- Linear combinations with polynomial coefficients of powers

$$p_1(n)\gamma_1^n + \cdots + p_\ell(n)\gamma_\ell^n.$$

- Taylor coefficients of rational functions.
- Coefficients of power series which are solutions of homogeneous linear differential equations.
- Sequence of coefficients of powers of a matrix.

Polynomial combinations of powers

Given polynomials p_1, \dots, p_ℓ in $\mathbb{K}[X]$ and elements $\gamma_1, \dots, \gamma_\ell$ in \mathbb{K}^\times , the sequence

$$(p_1(n)\gamma_1^n + \cdots + p_\ell(n)\gamma_\ell^n)_{n \geq 0}$$

is a linear recurrence sequence, the minimal polynomial of which is of the form

$$X^d - a_1 X^{d-1} - \cdots - a_d = \prod_{i=1}^{\ell} (X - \gamma_i)^{t_i},$$

Fact : any linear recurrence sequence is of this form.

Consequence : the sum and the product of any two linear recurrence sequences are linear recurrence sequences. The set of all linear recurrence sequences with coefficients in \mathbb{K} is a sub- \mathbb{K} -algebra of $\mathbb{K}^{\mathbb{N}}$.

ICSFA-2018

November 22 - 24, 2018

International Conference on Special Functions & Applications
Amal Jyothi College on Engineering, Kanjirapalli, Kottayam (Kerala).

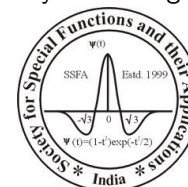

Linear recurrence sequences: an introduction

Michel Waldschmidt

Institut de Mathématiques de Jussieu — Sorbonne Université
<http://www.math.jussieu.fr/~michel.waldschmidt/>