

Kyoto, 12 juillet - 22 septembre 2022.



Tobu Hotel Narita Airport (chambre (530), 12 juillet 2022.
Tout ce vert...





Roppongi, un soir d'orage, 12 juillet 2022.

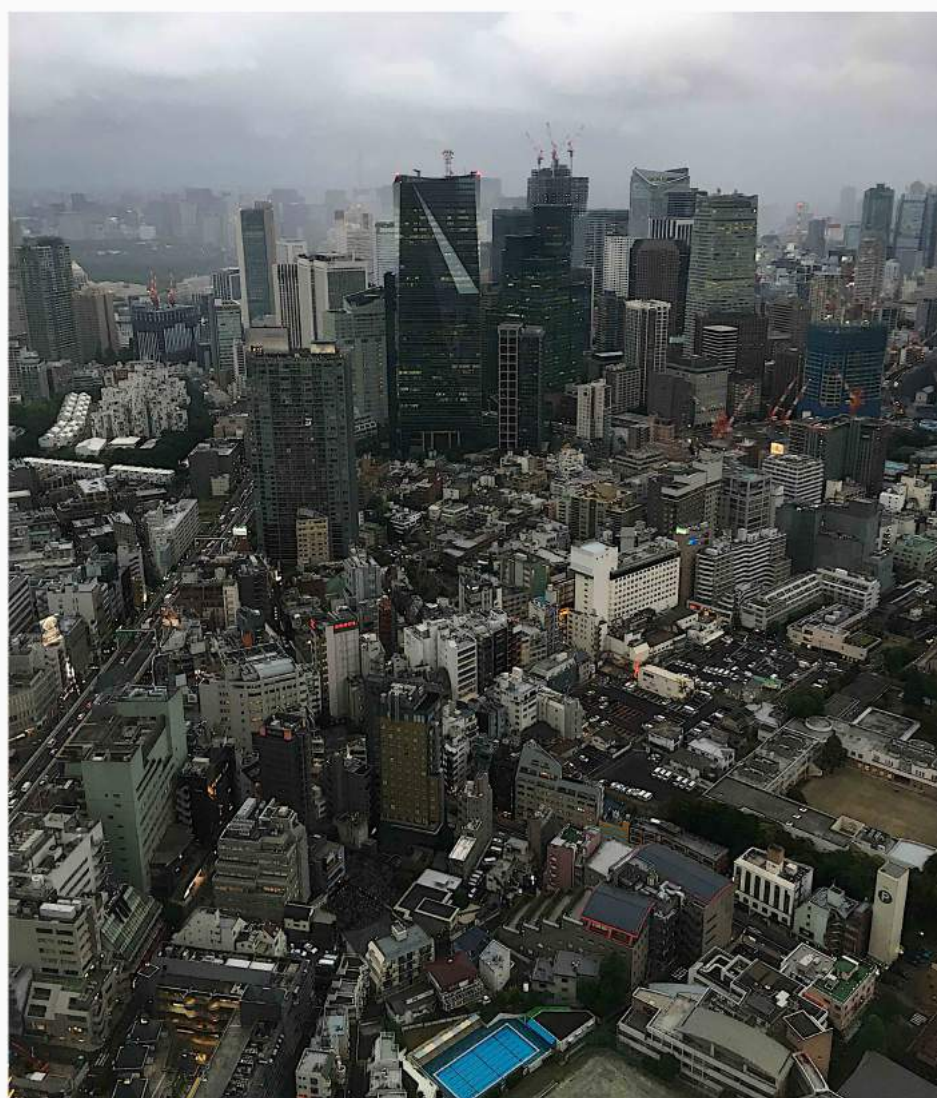



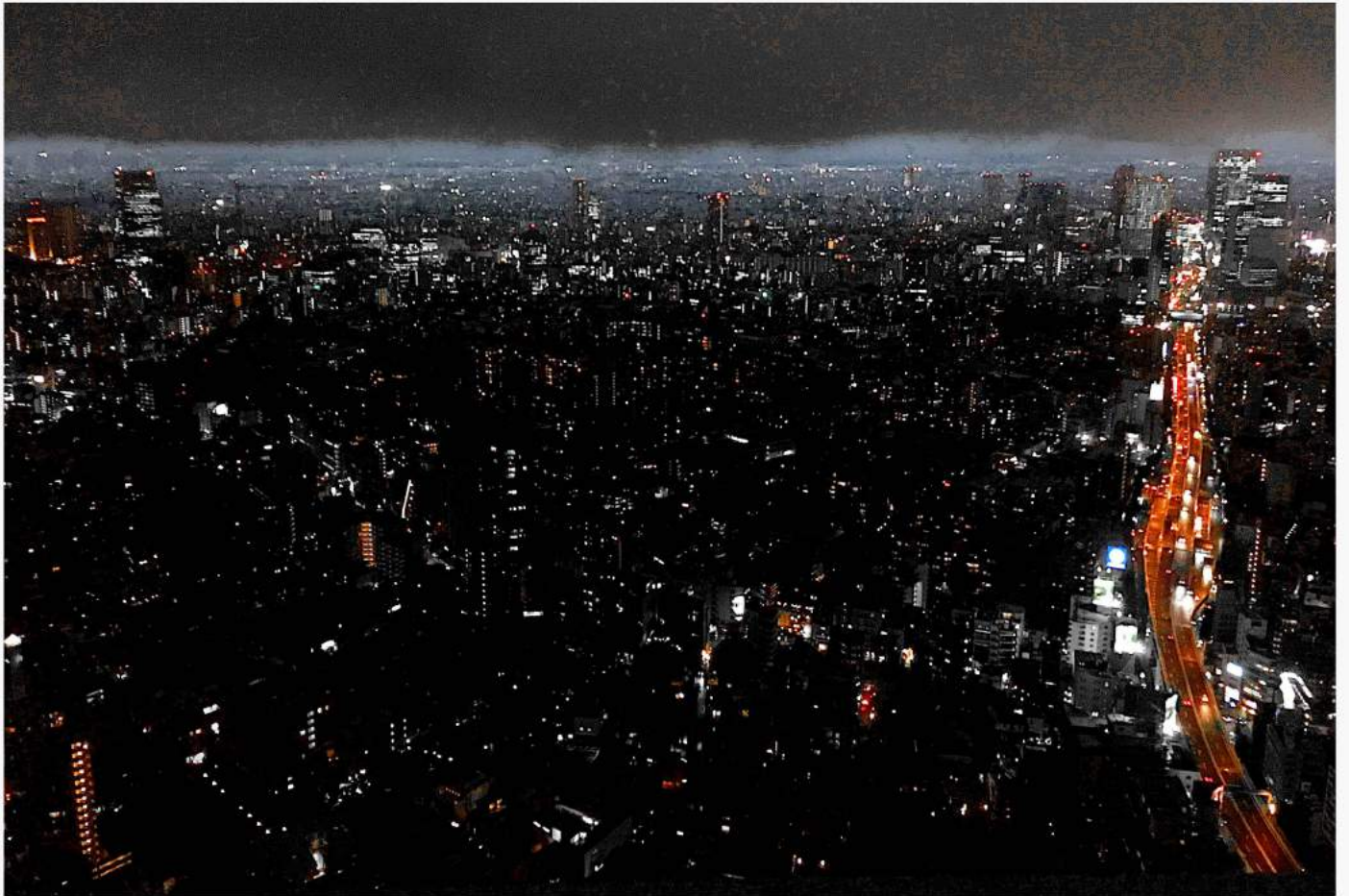



Canal Okazaki, 24 juillet 2022.





Du pont de Nijo, 31 juillet 2022.



Synchronicité 4



Du pont de Nijo, 1er août 2022.



Shimogamo Jinja, 6 août 2022.



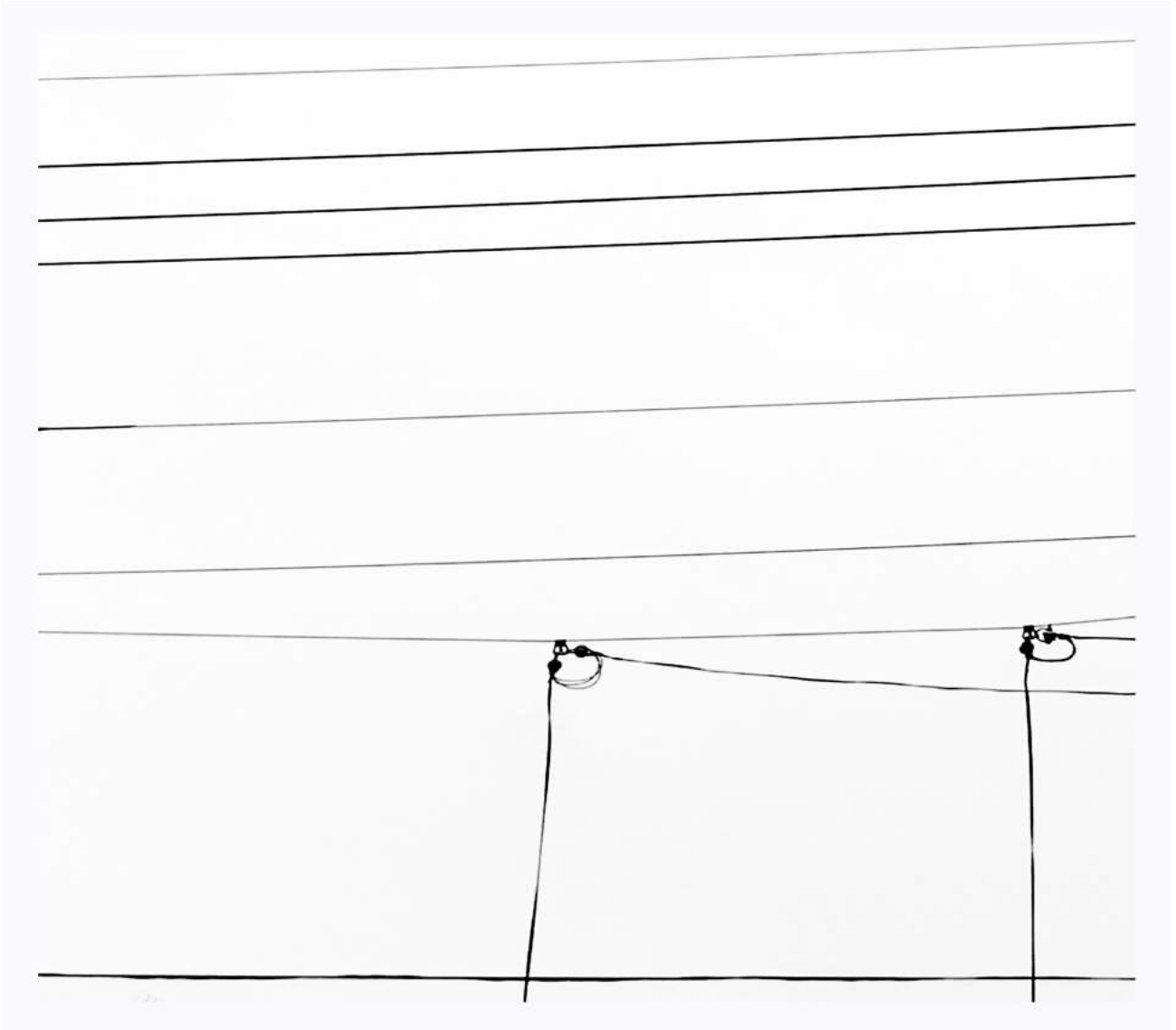

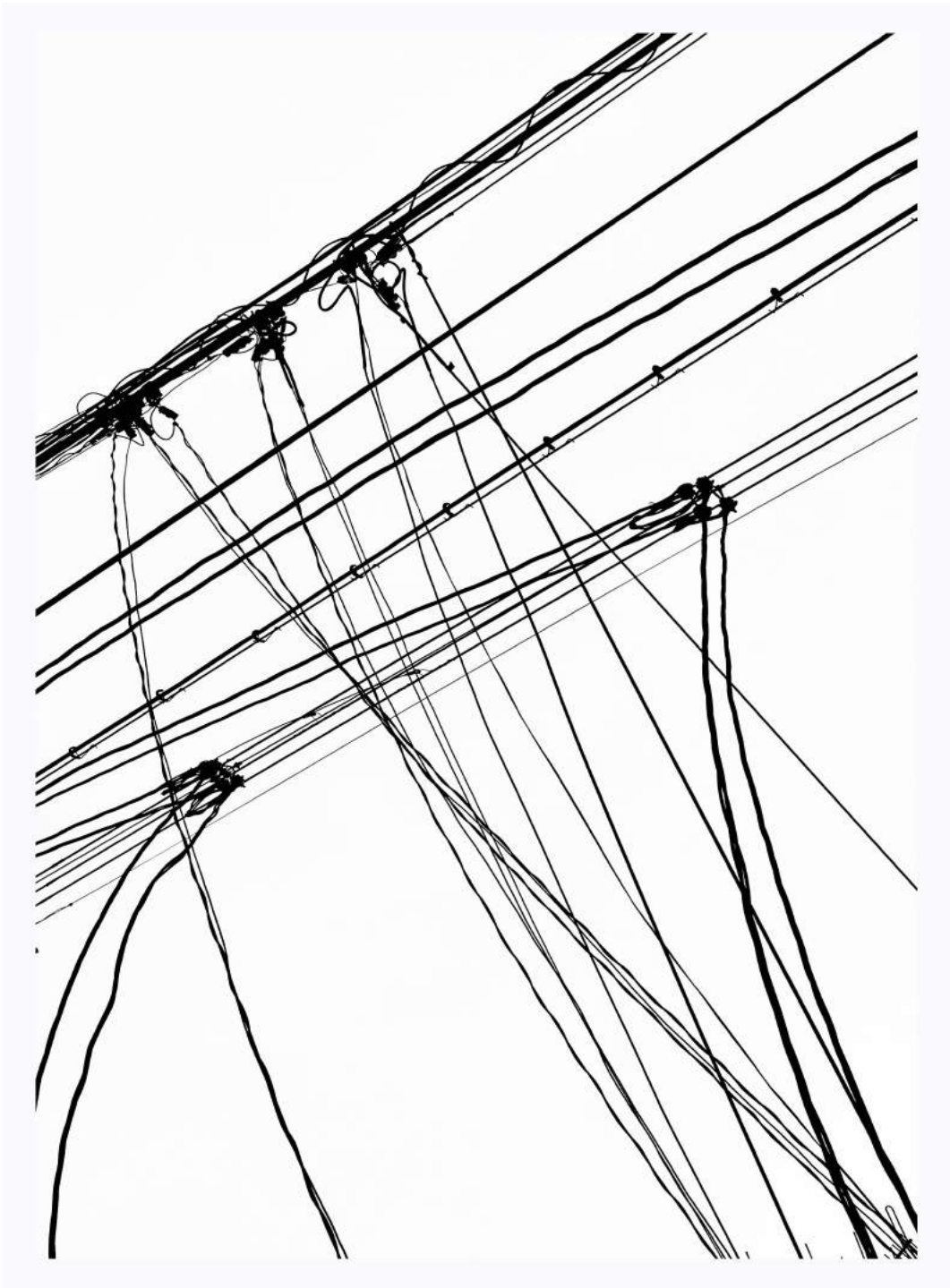

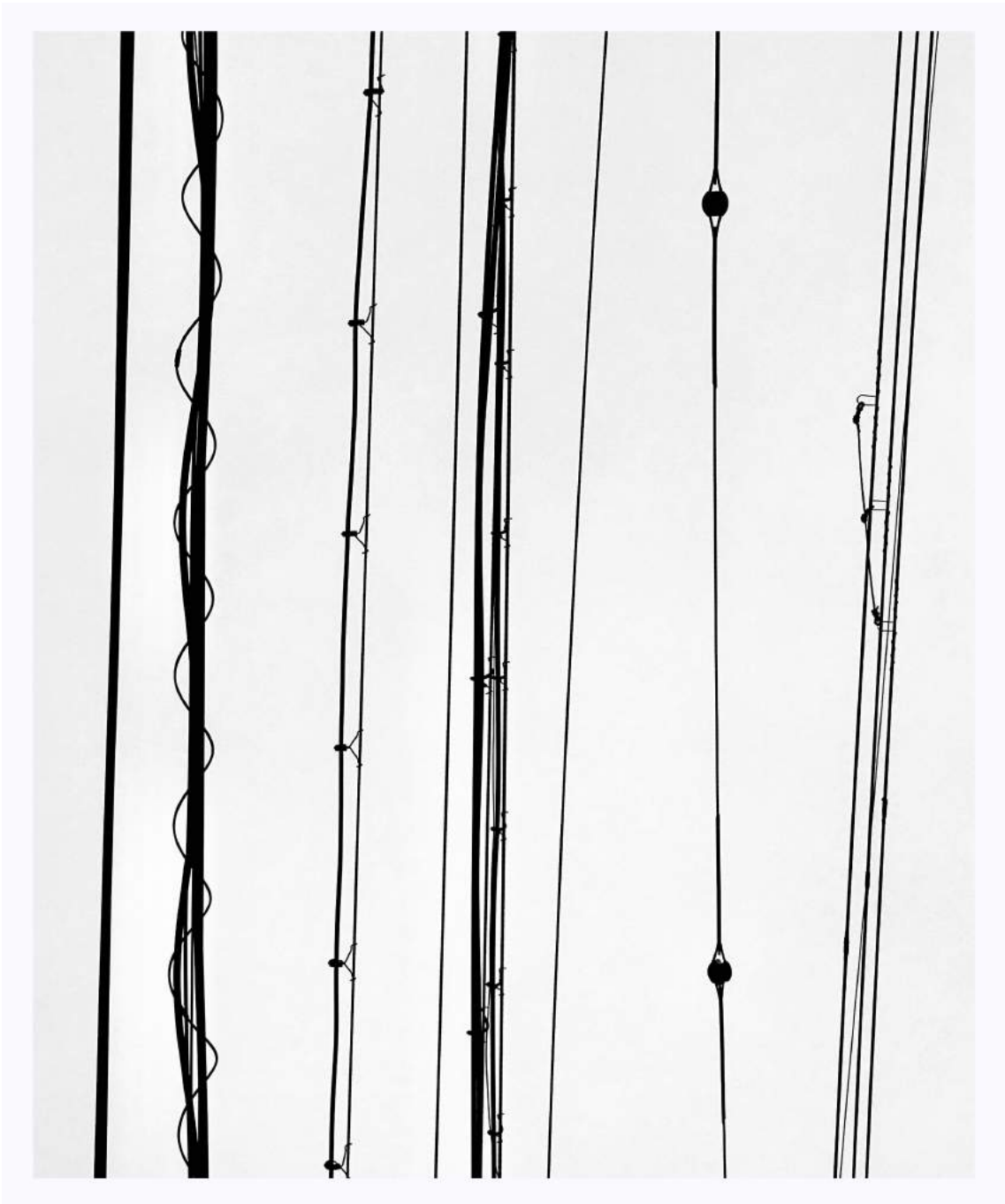

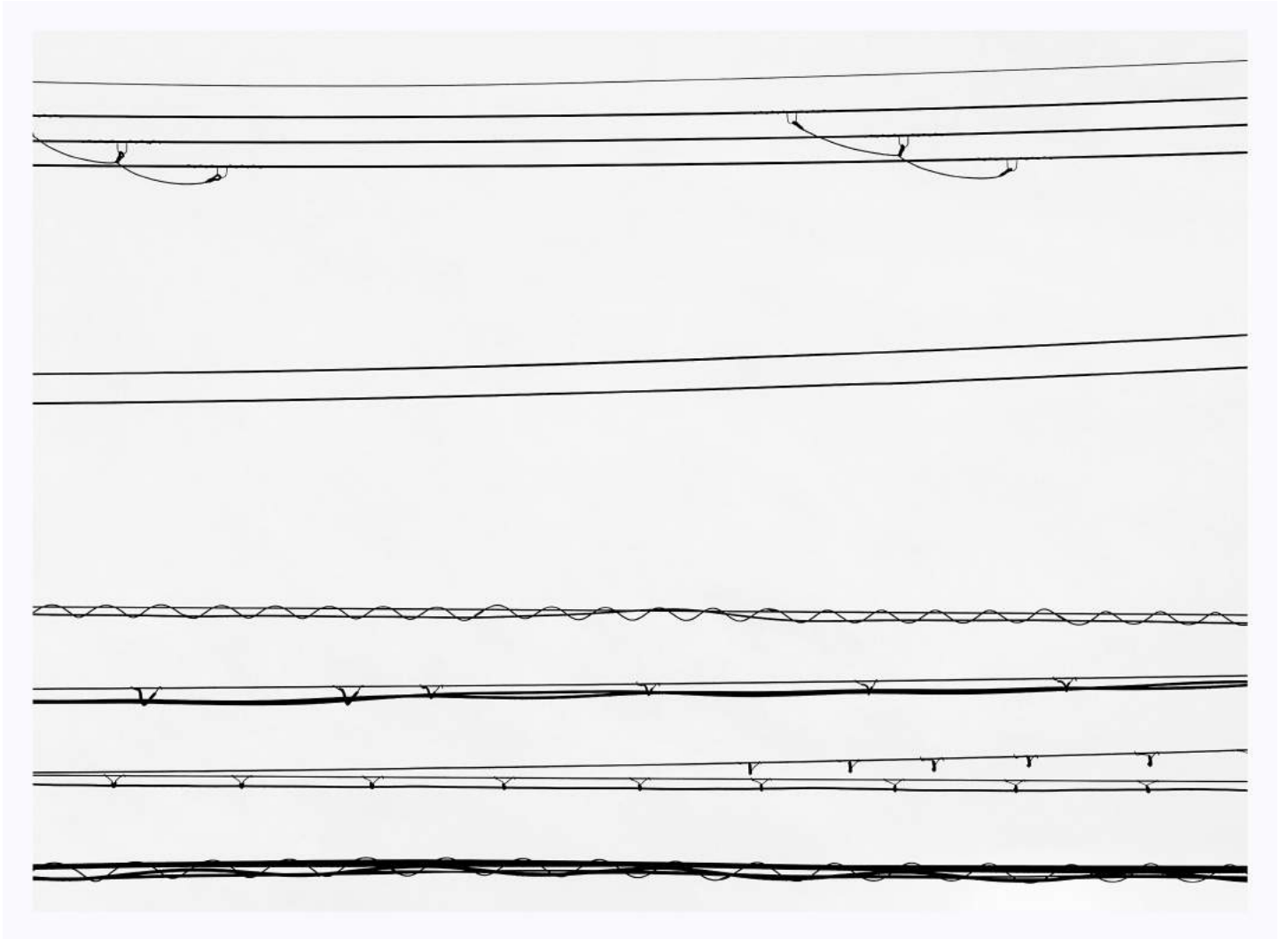

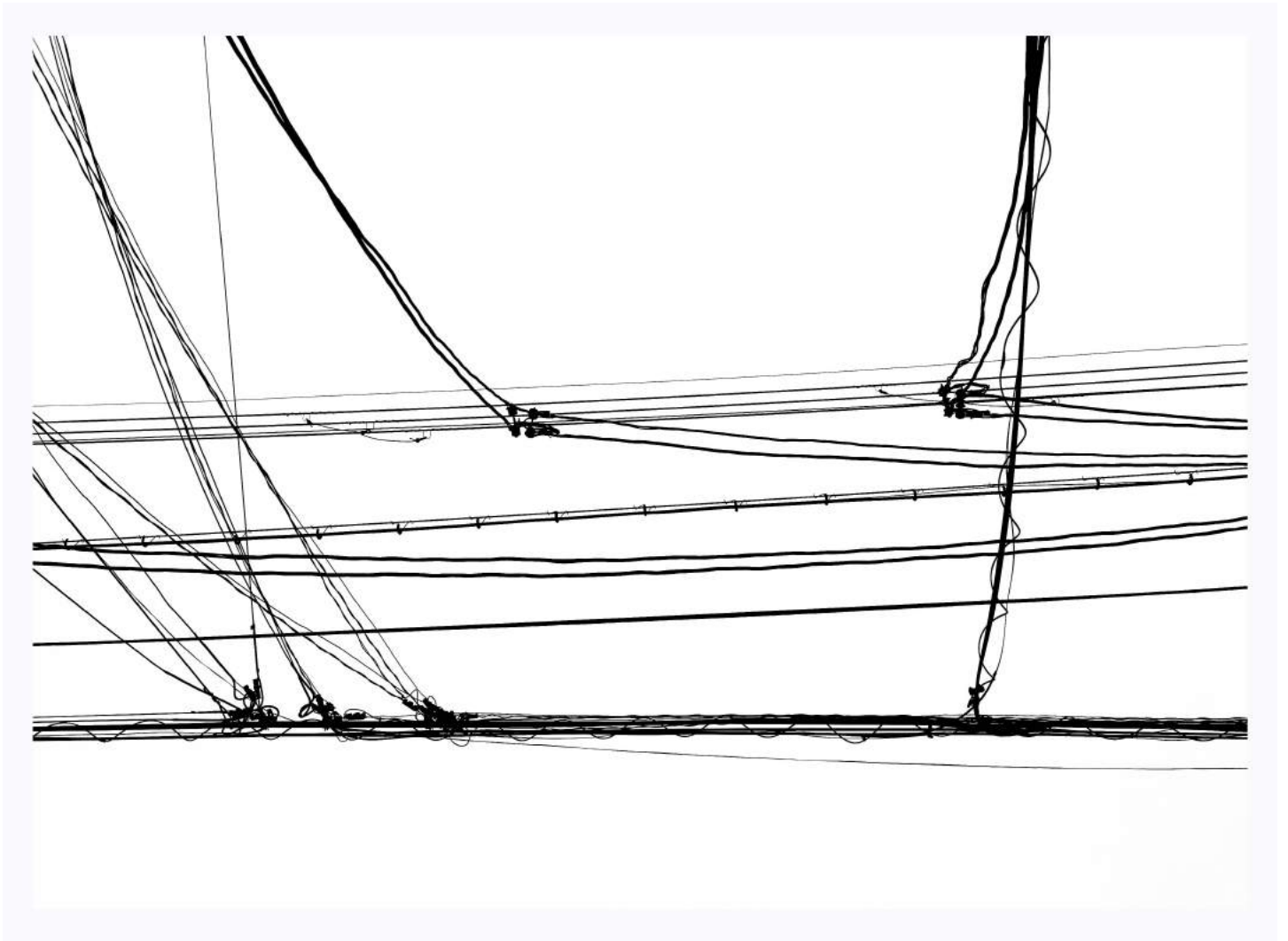

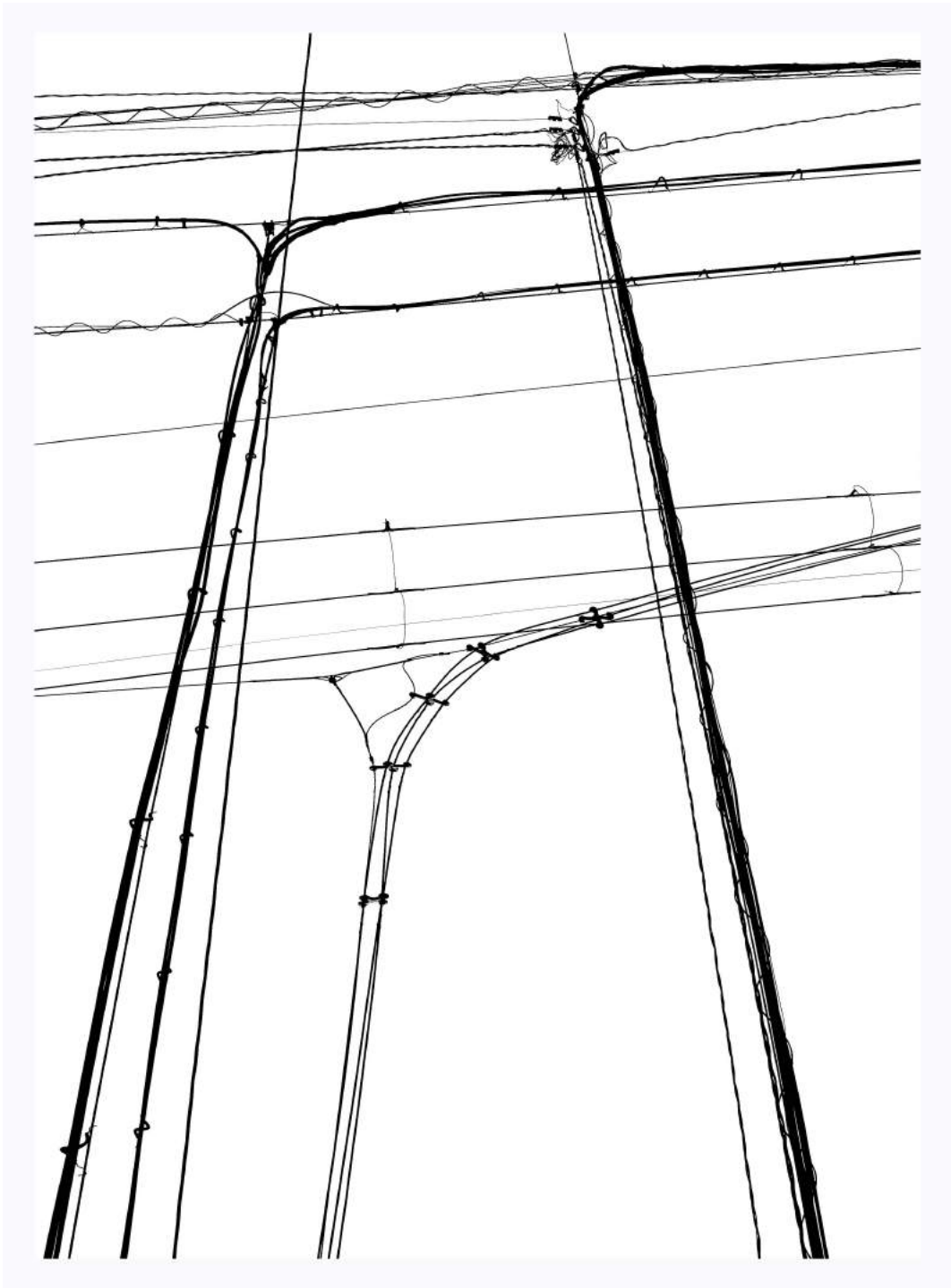

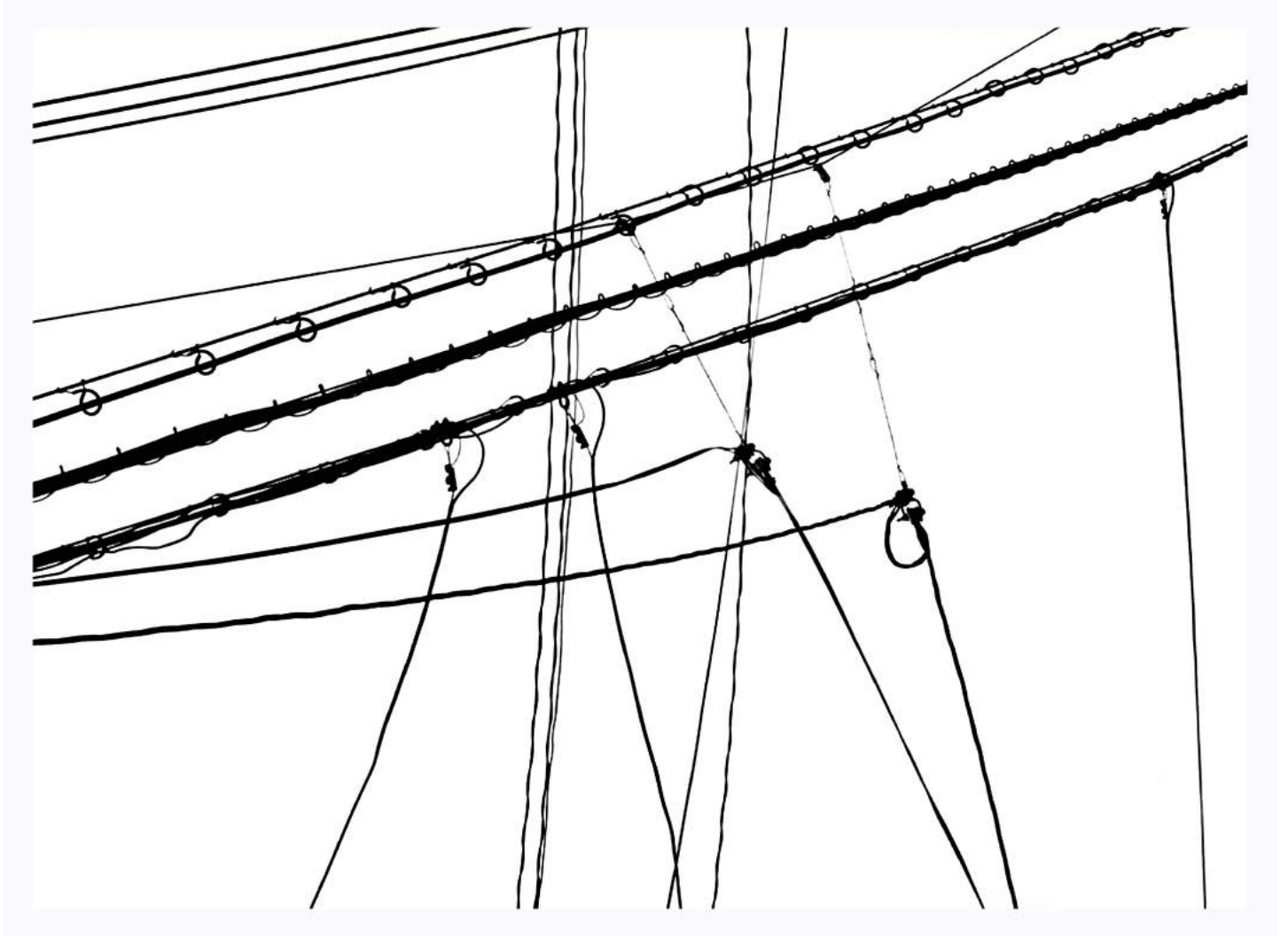



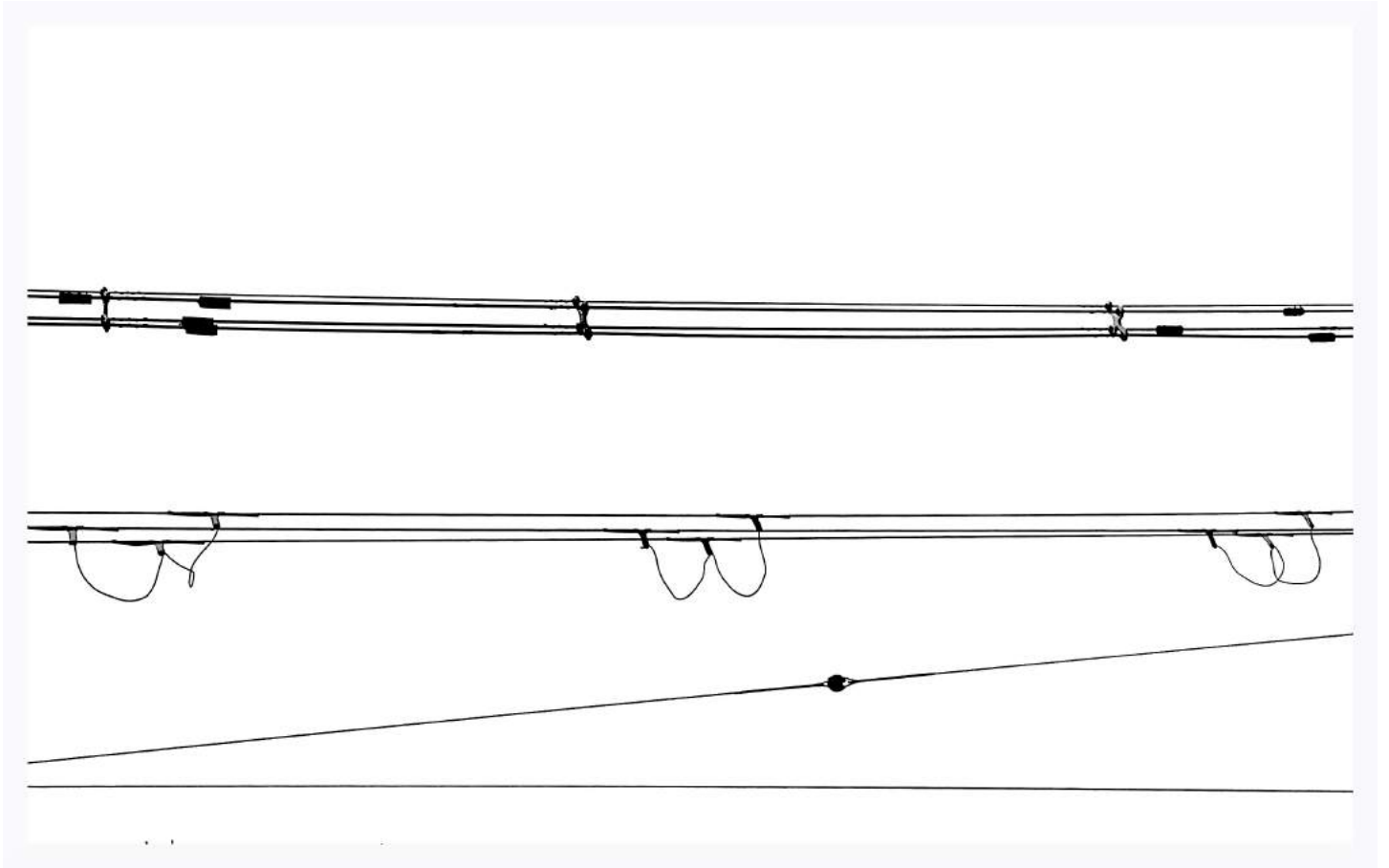



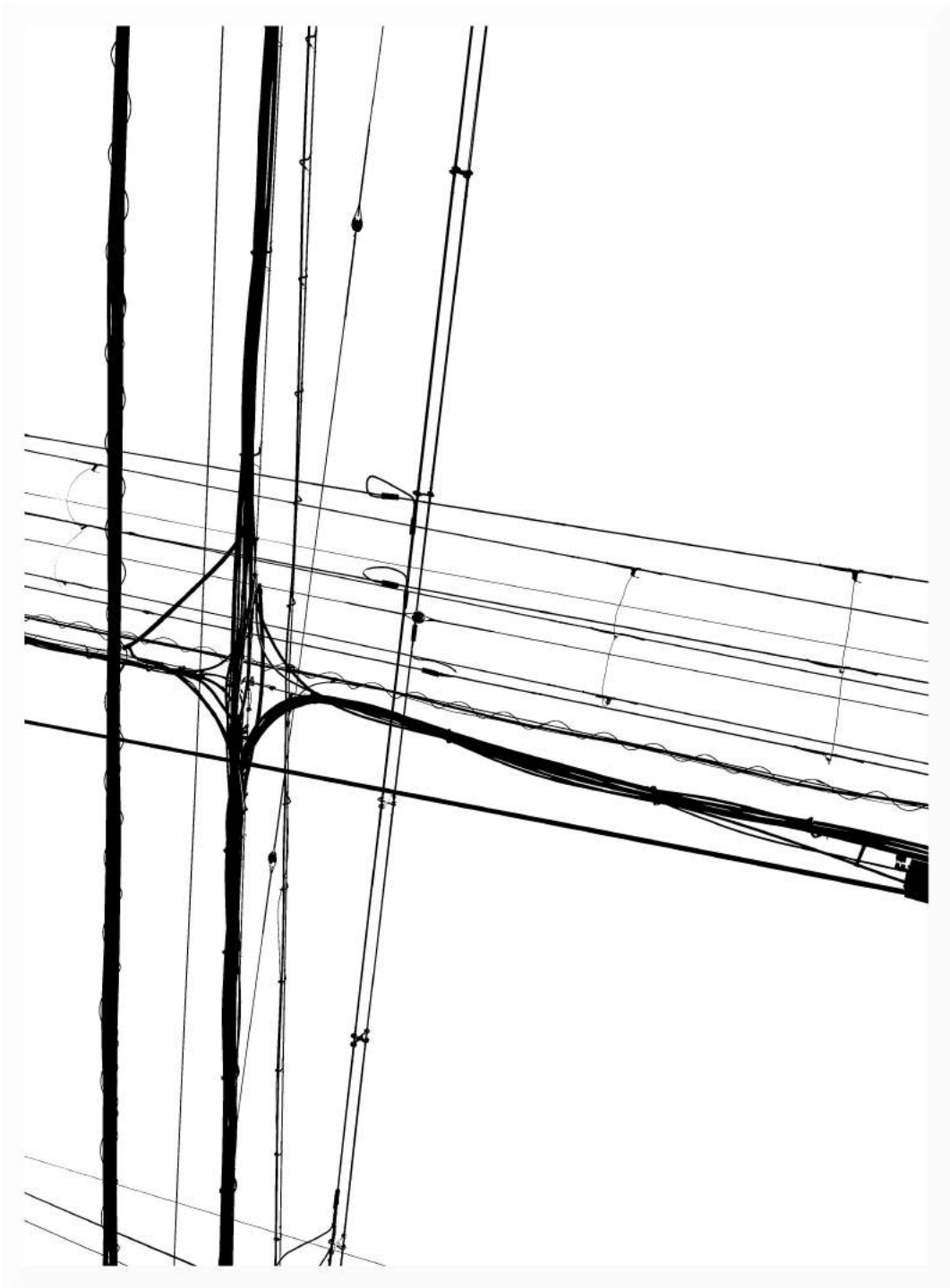

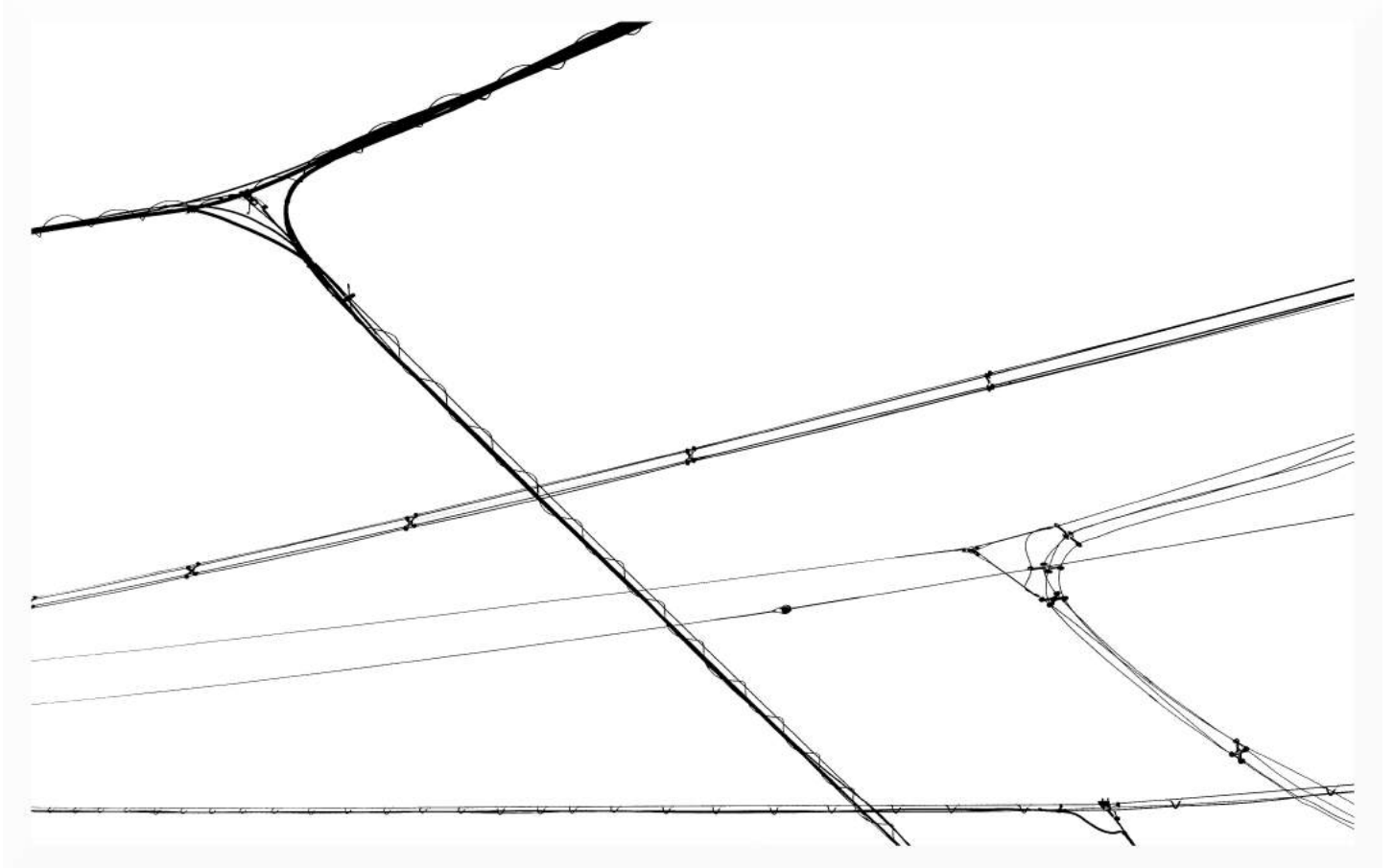

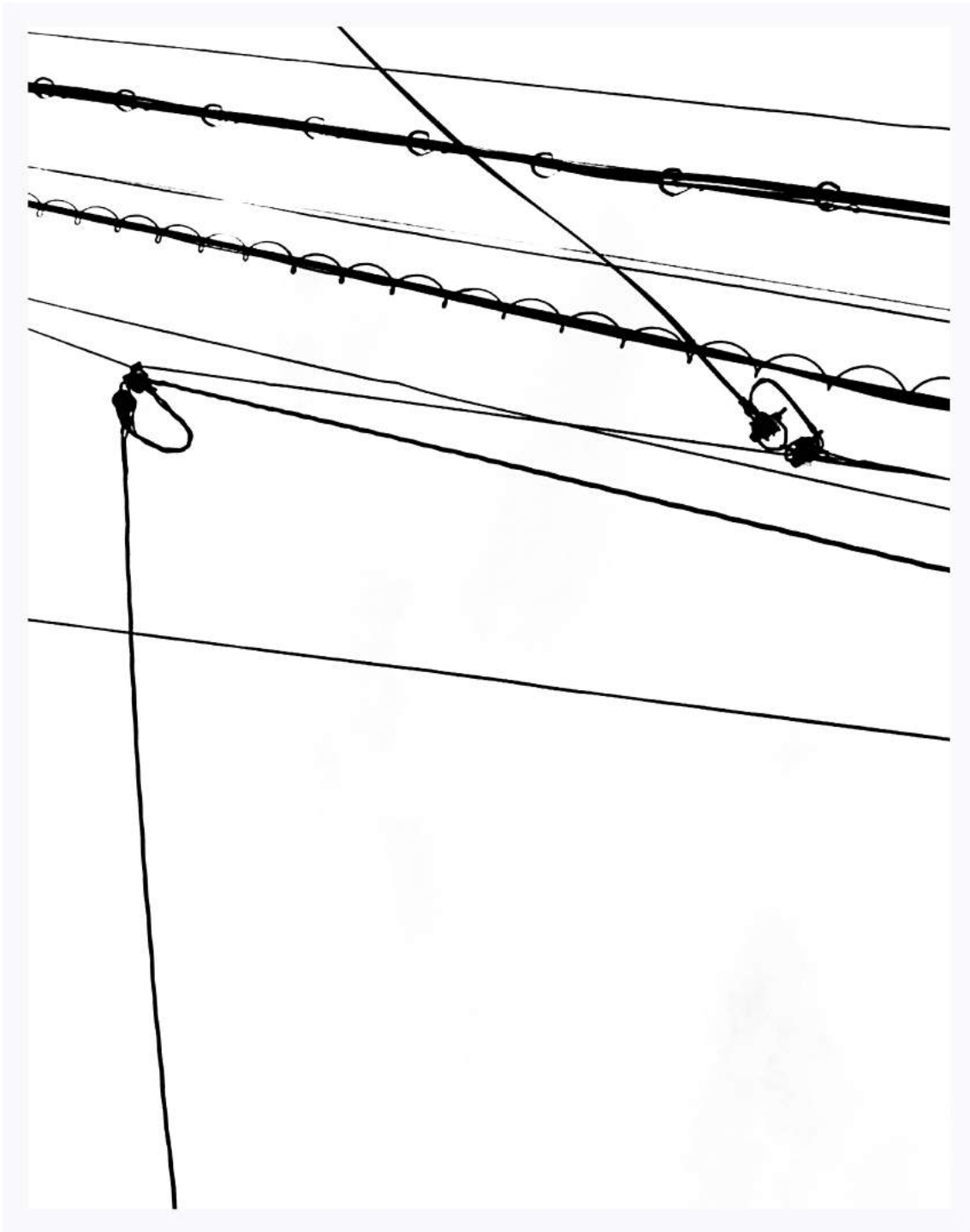

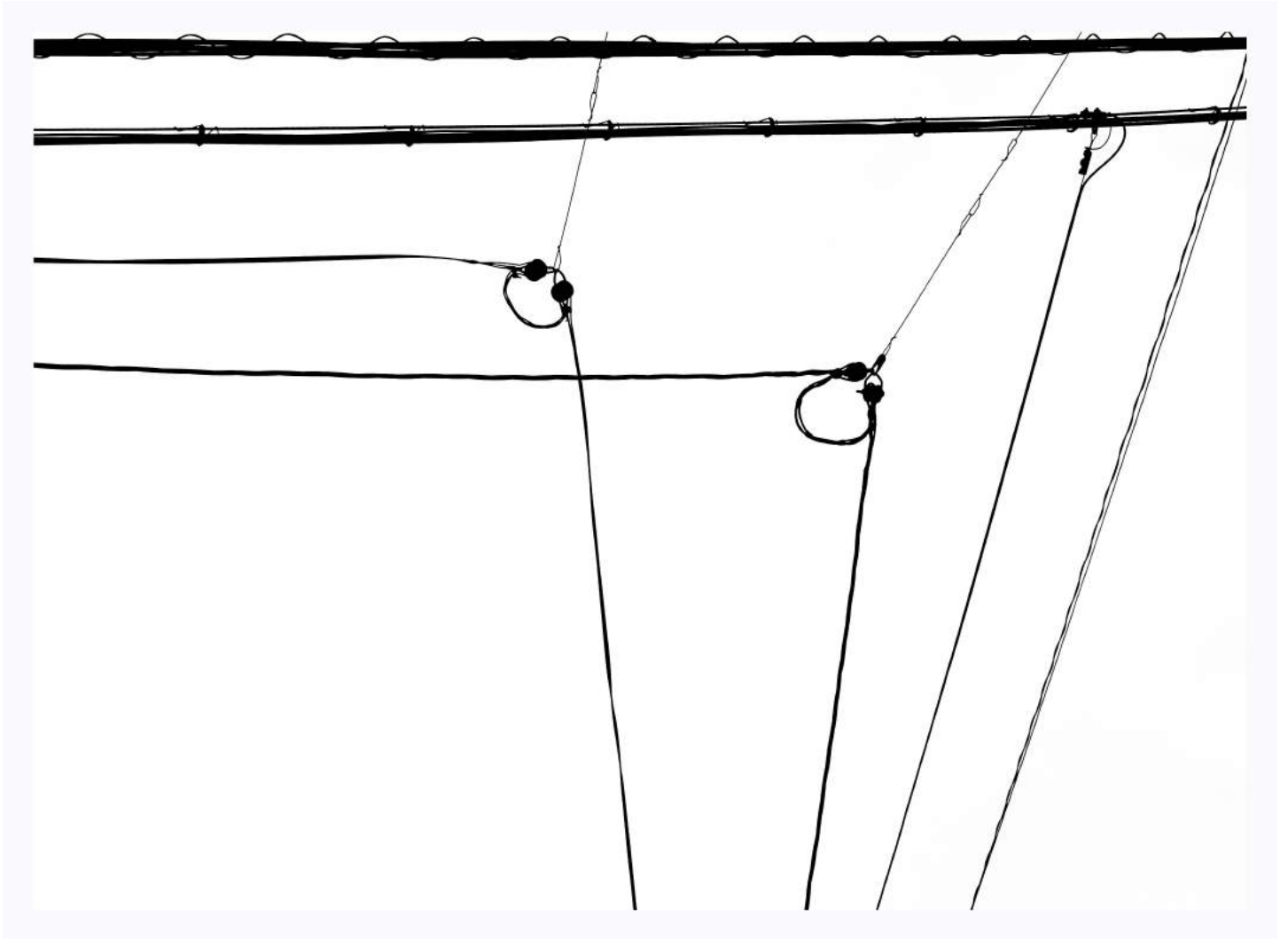

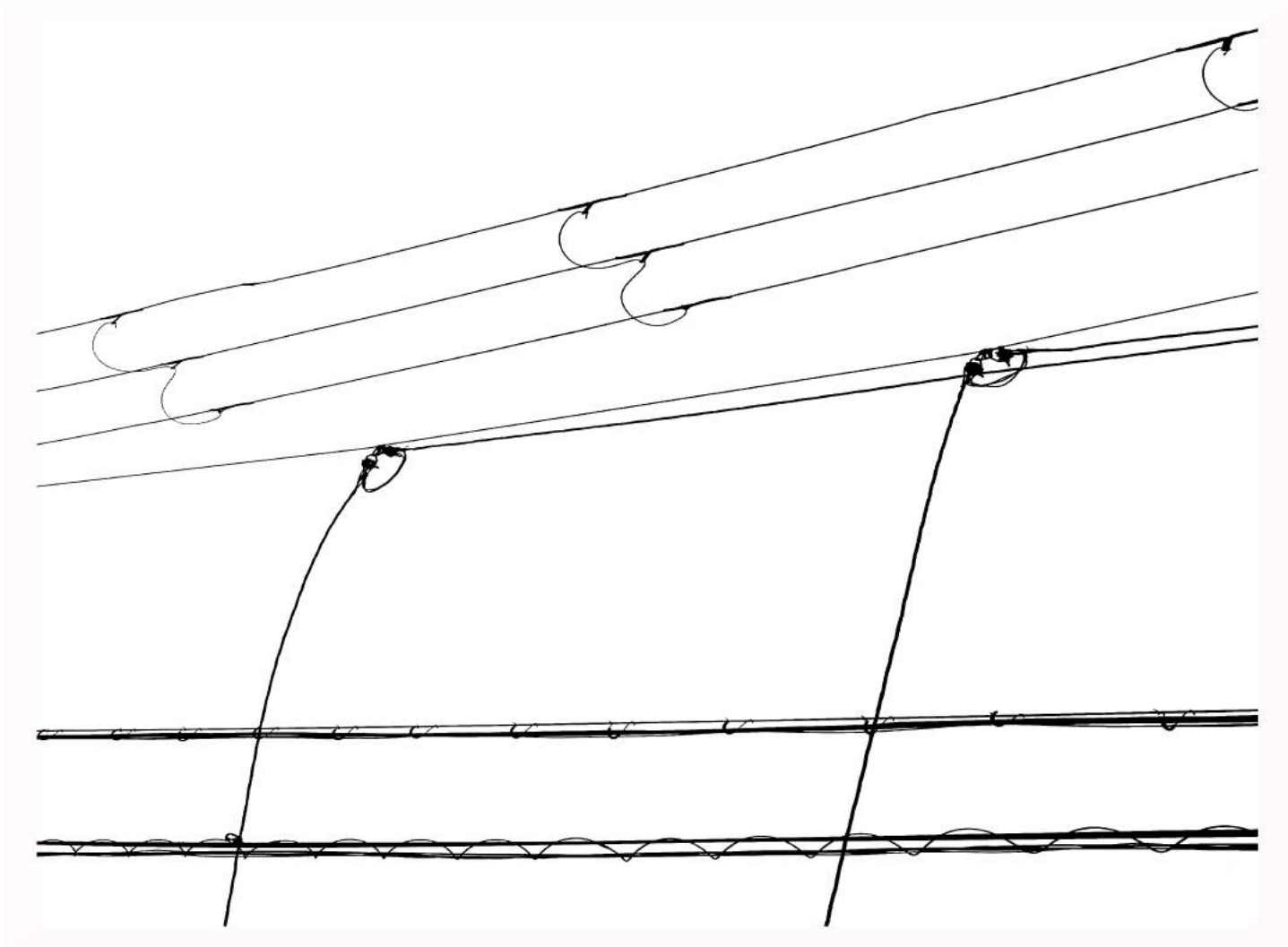

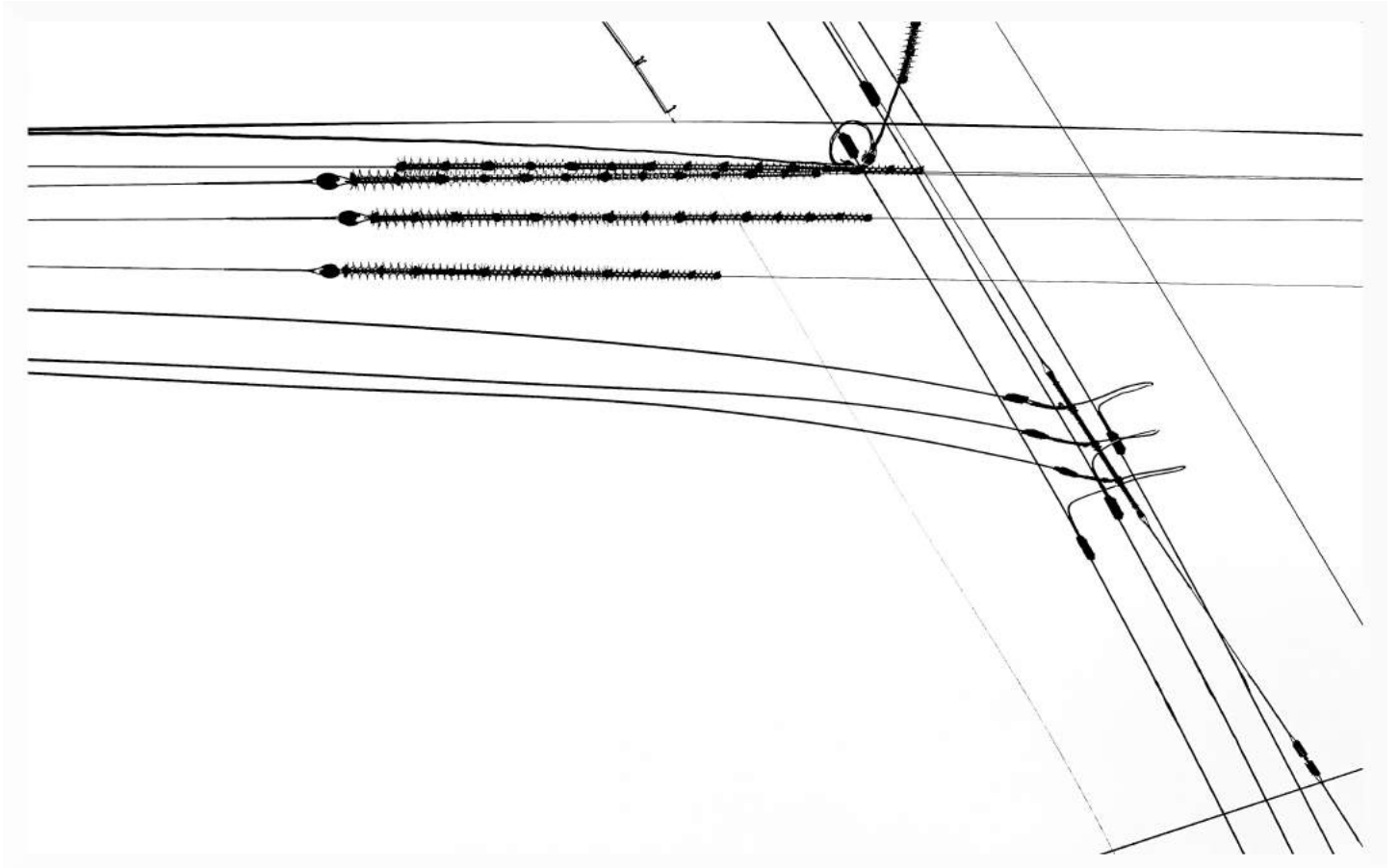



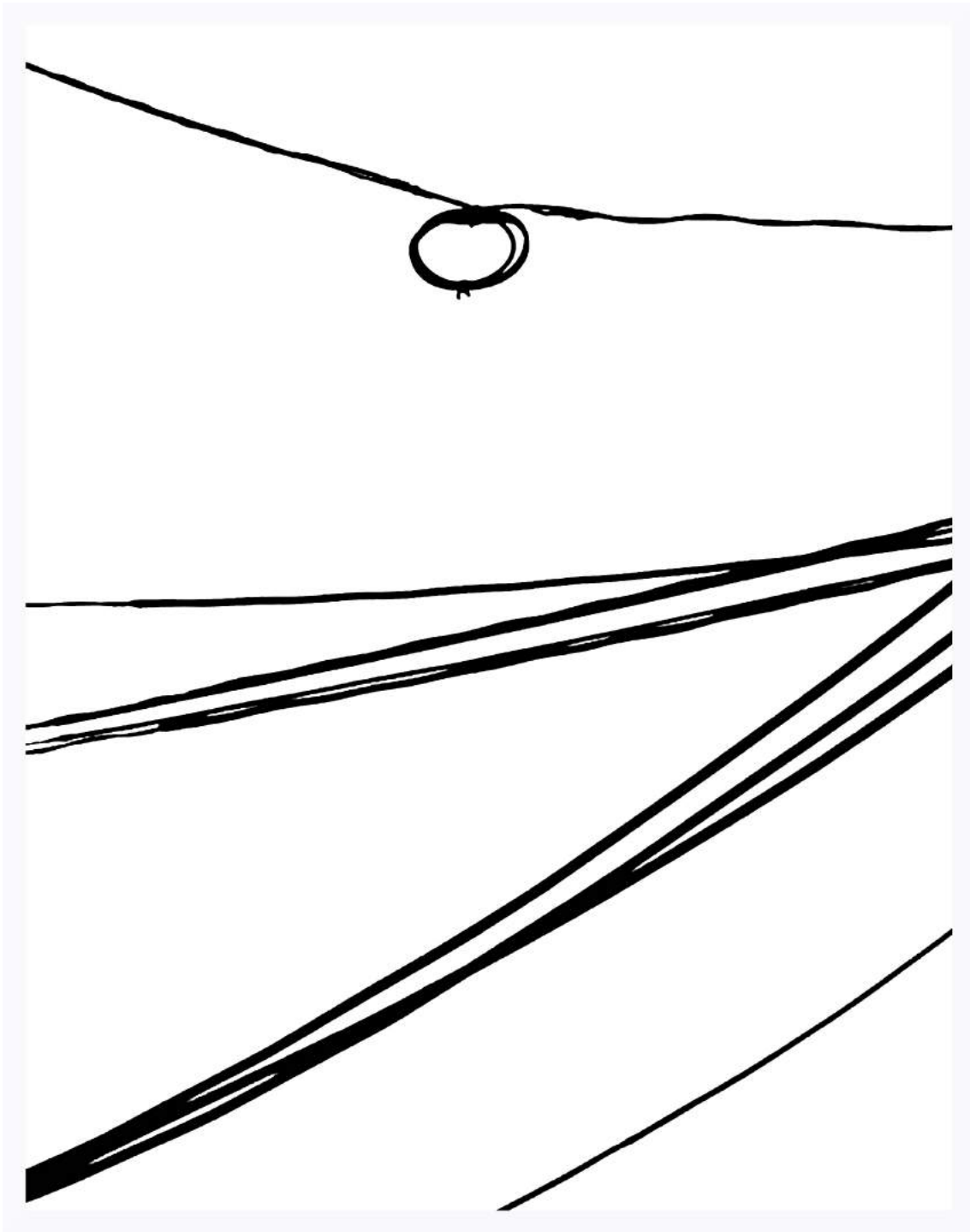

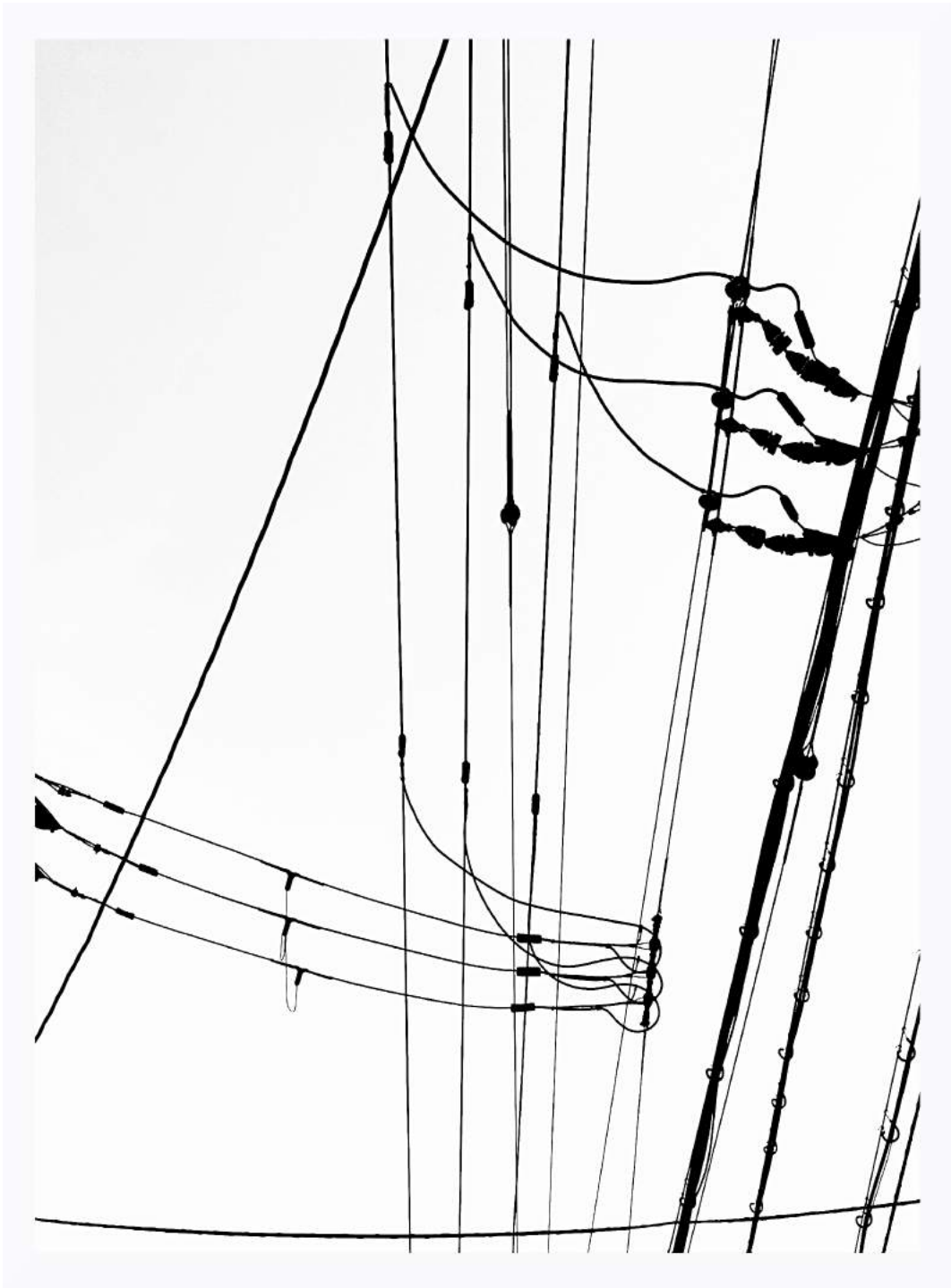

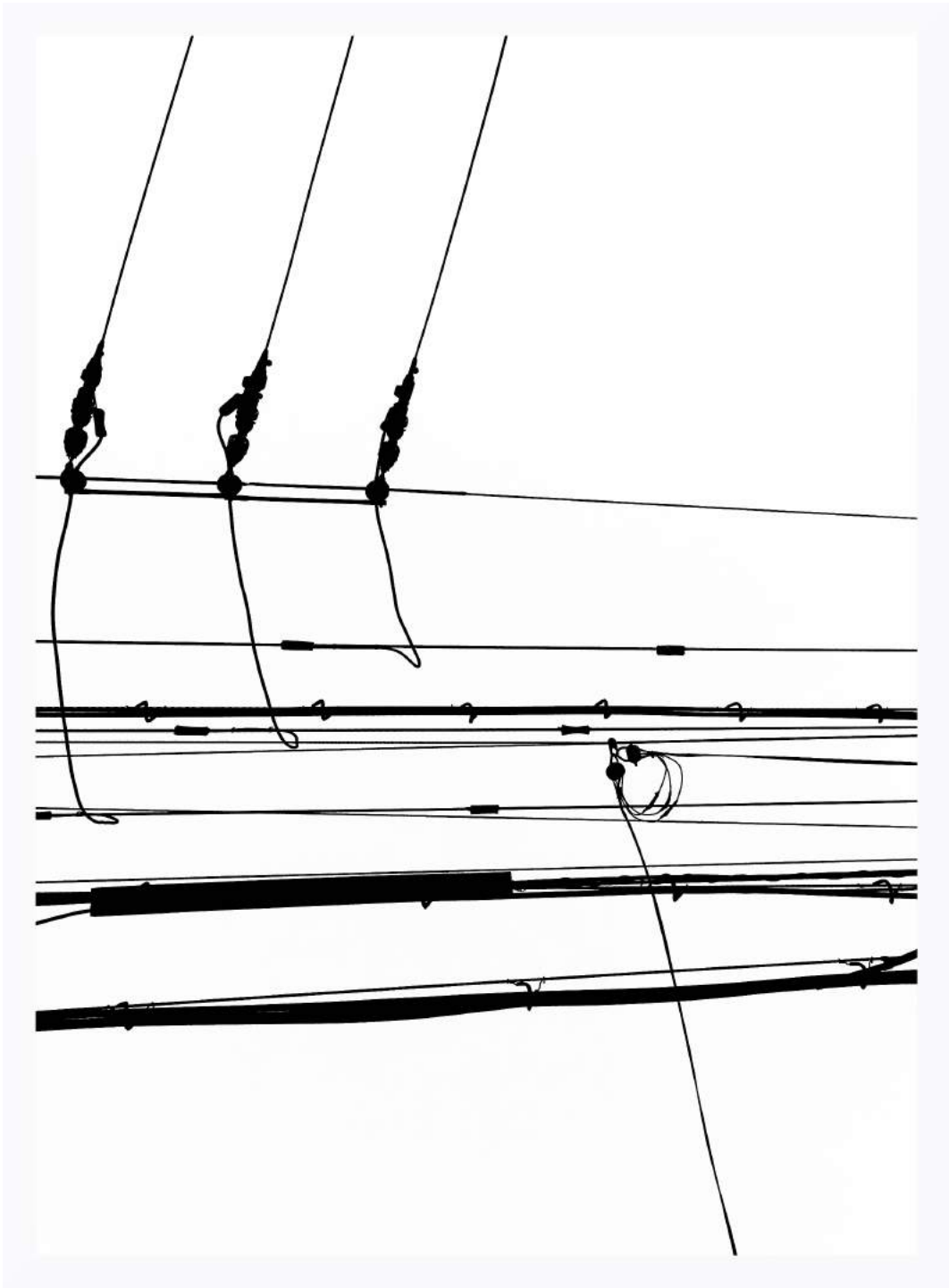

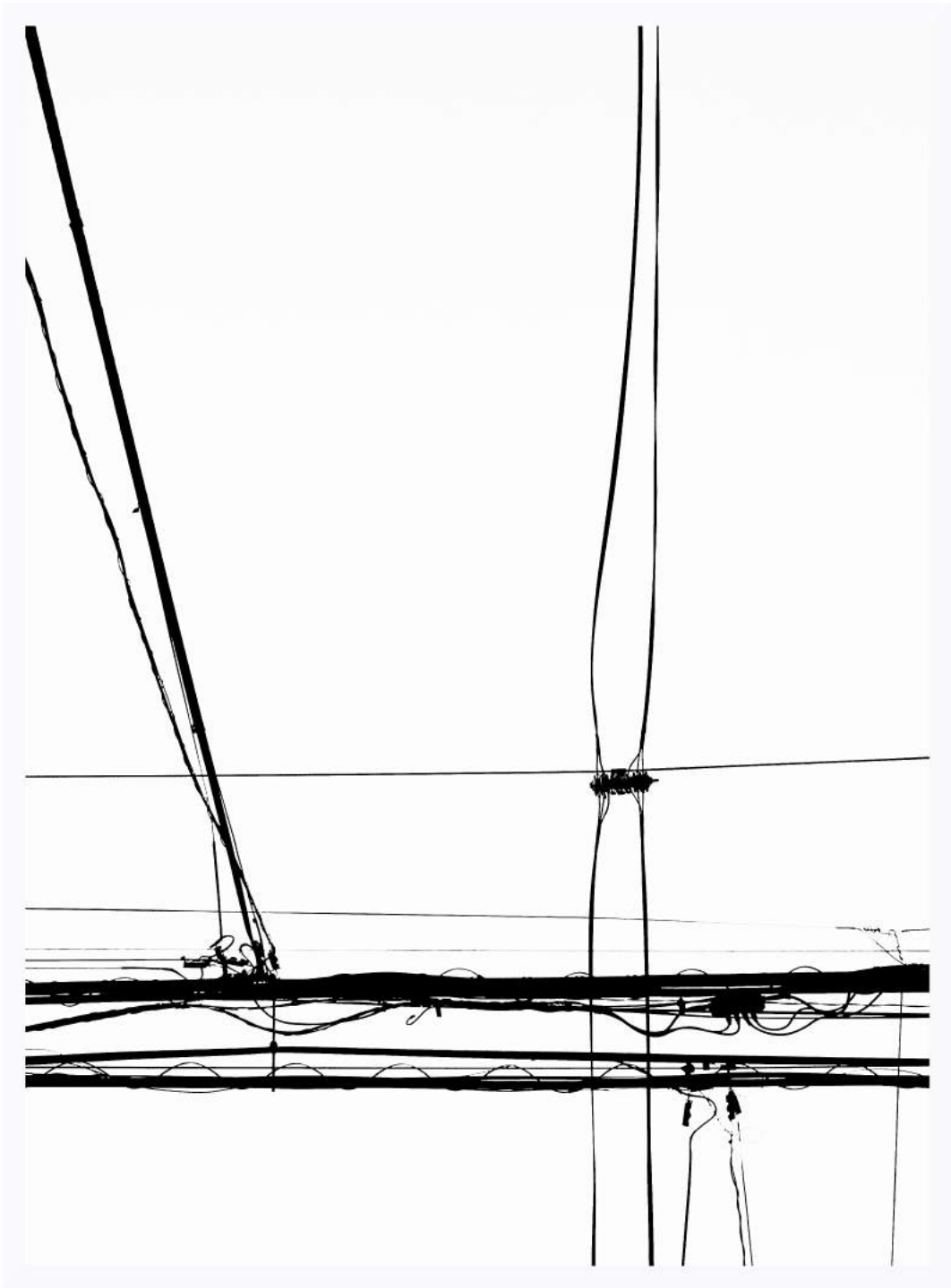

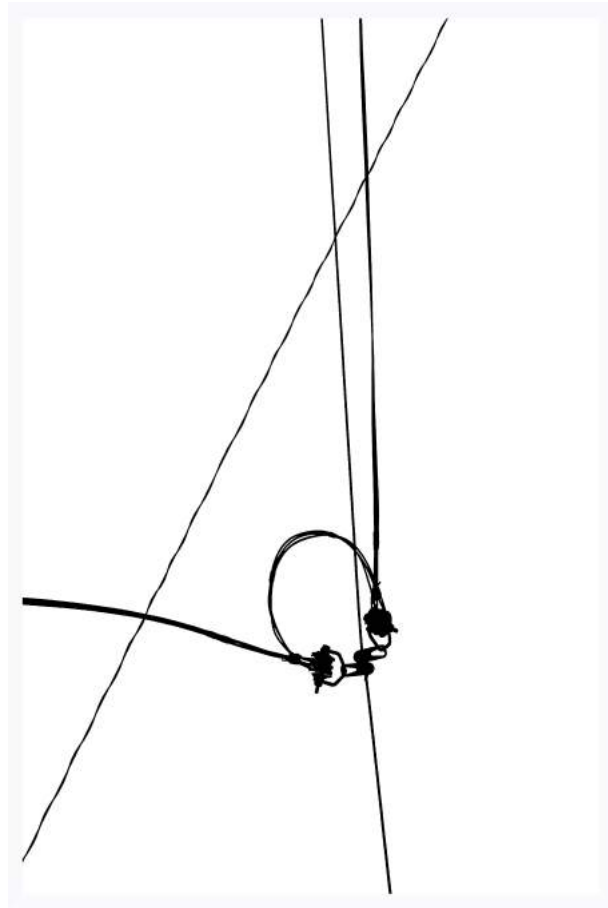
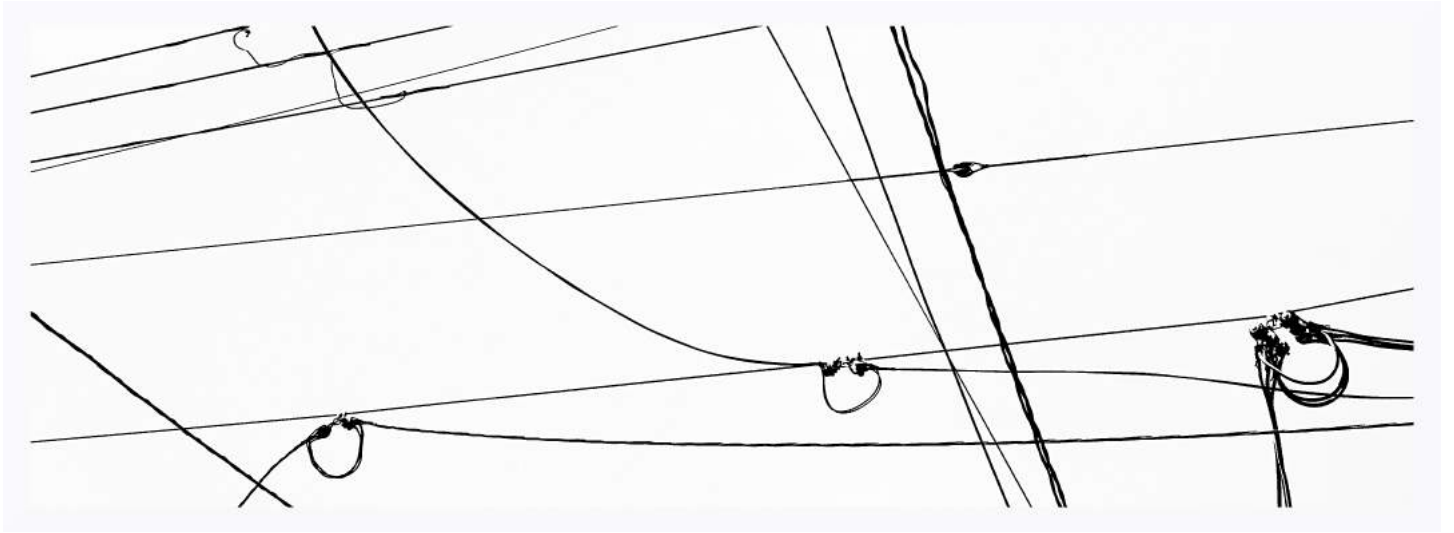



Près de Monko-ji - une plaque de métal couvrant une machiya décatie, 21 août 2022.



Fushimi Inari, 28 août 2022.

Je n'étais pas retourné à Fushimi Inari depuis janvier 2007. Ils ont beaucoup aménagé le site. Mais la nuit, les chats prennent possession des lieux et les sanctuaires retrouvent leur charme inquiétant.









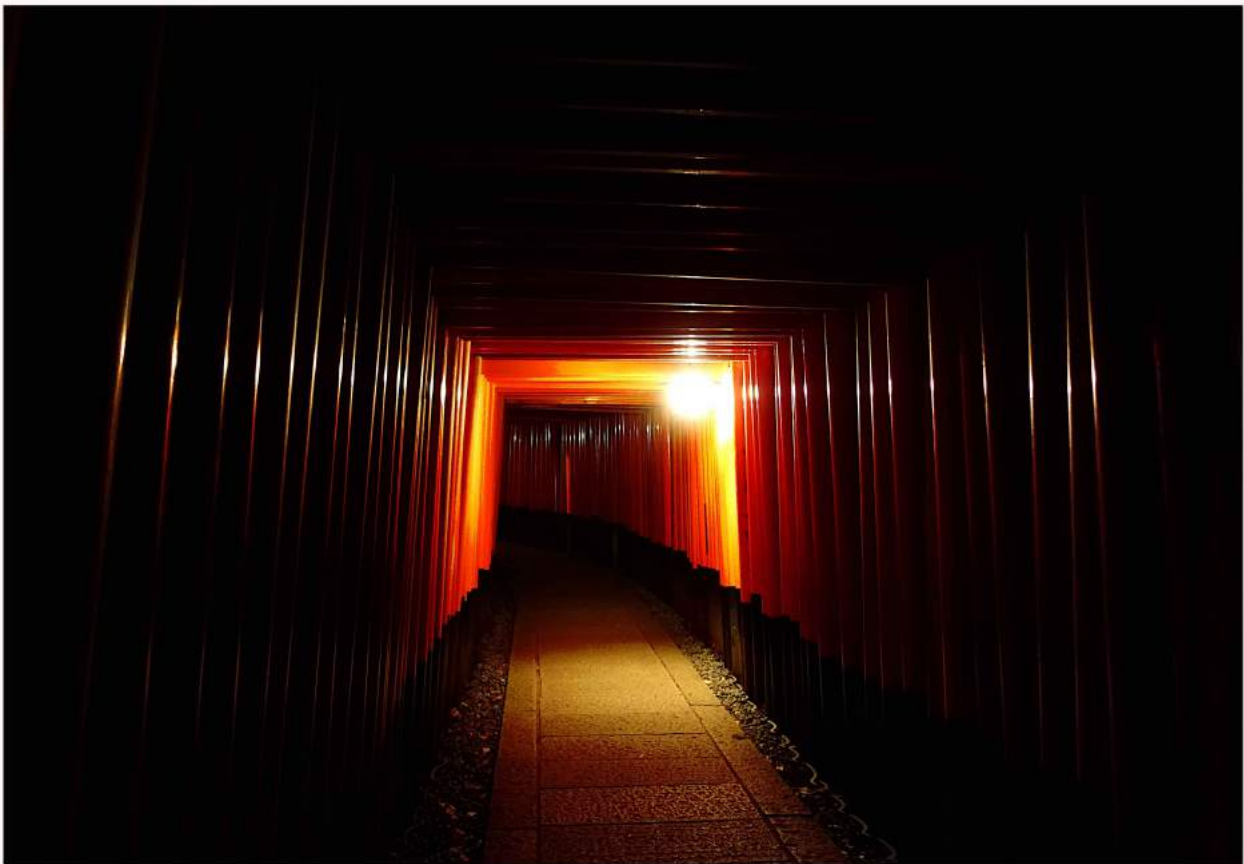

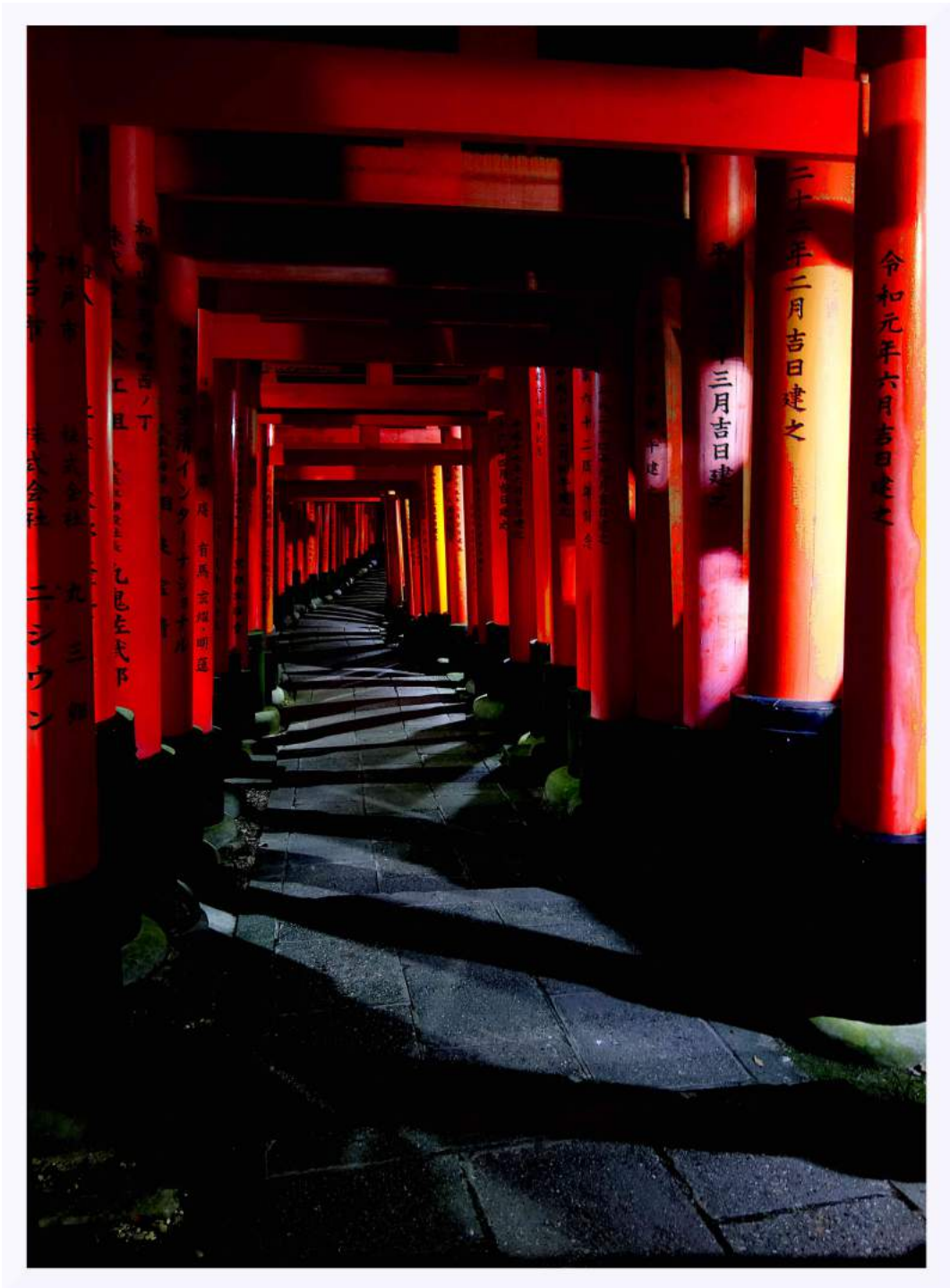

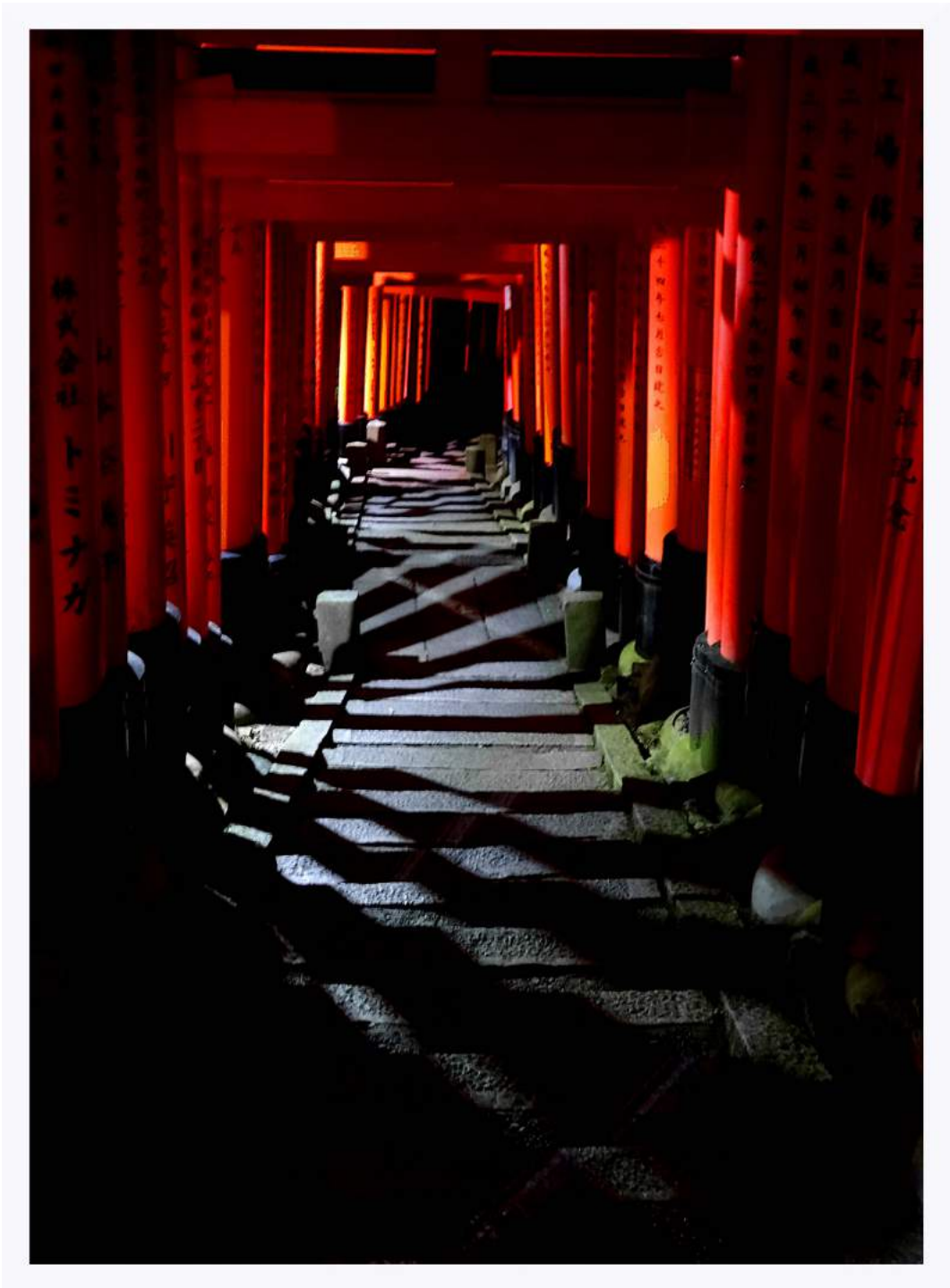

Il me semble qu'il y a une certaine désinvolture à laisser ainsi sa carte de visite à l'esprit du lieu... Mais il s'agit sûrement de l'une des arcanes du rituel de la carte de visite qui m'échappe.

名刺

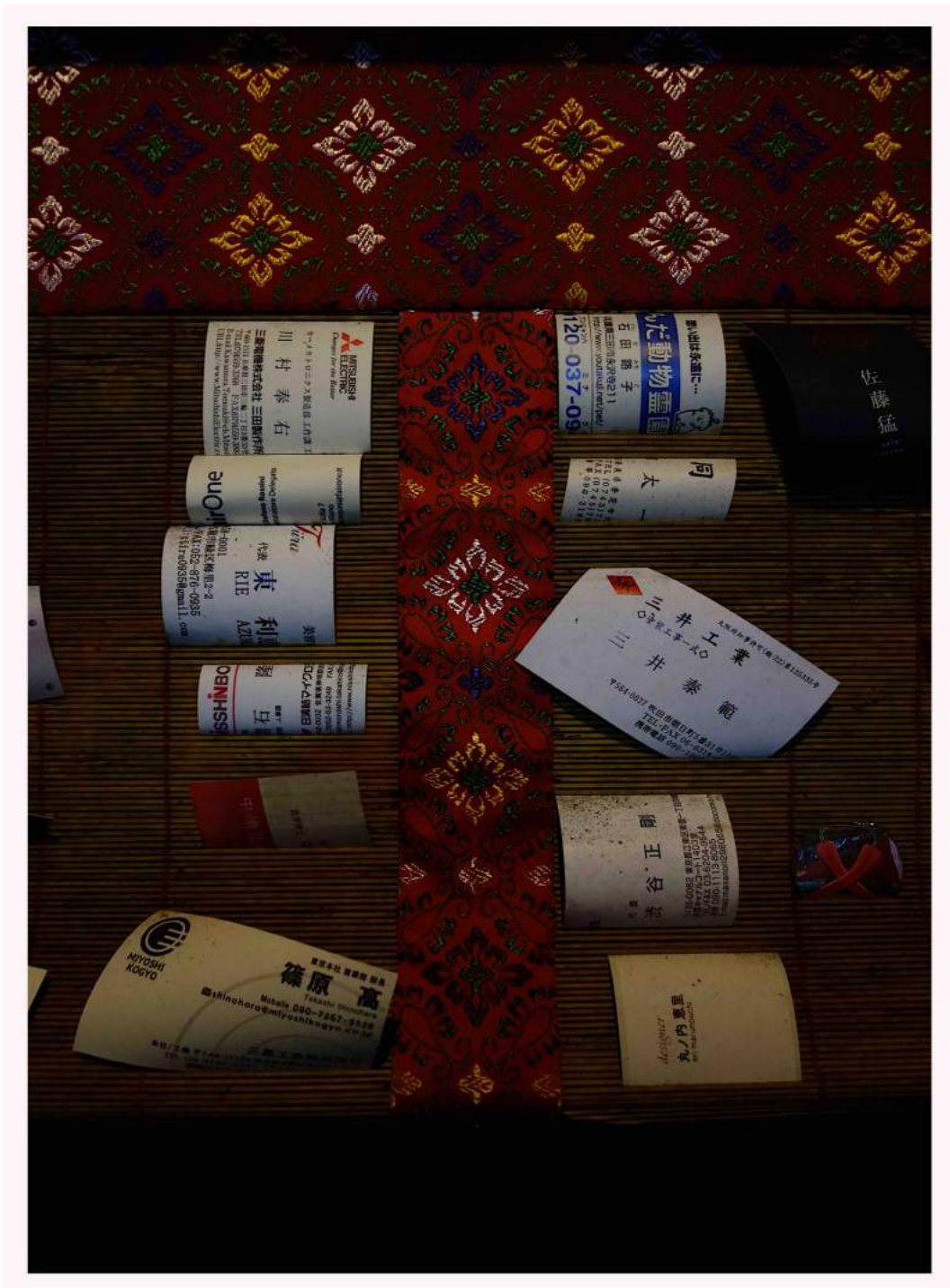

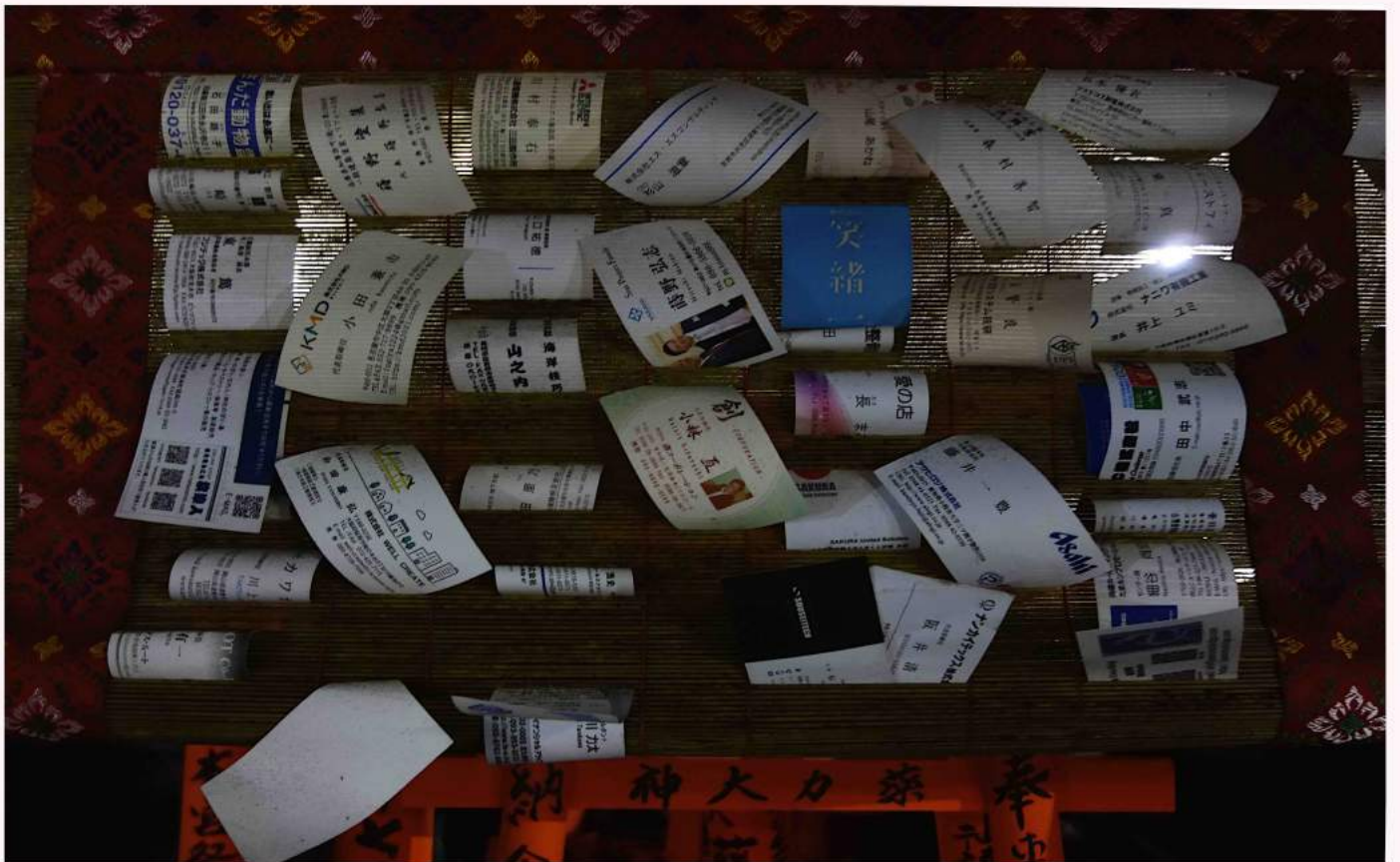

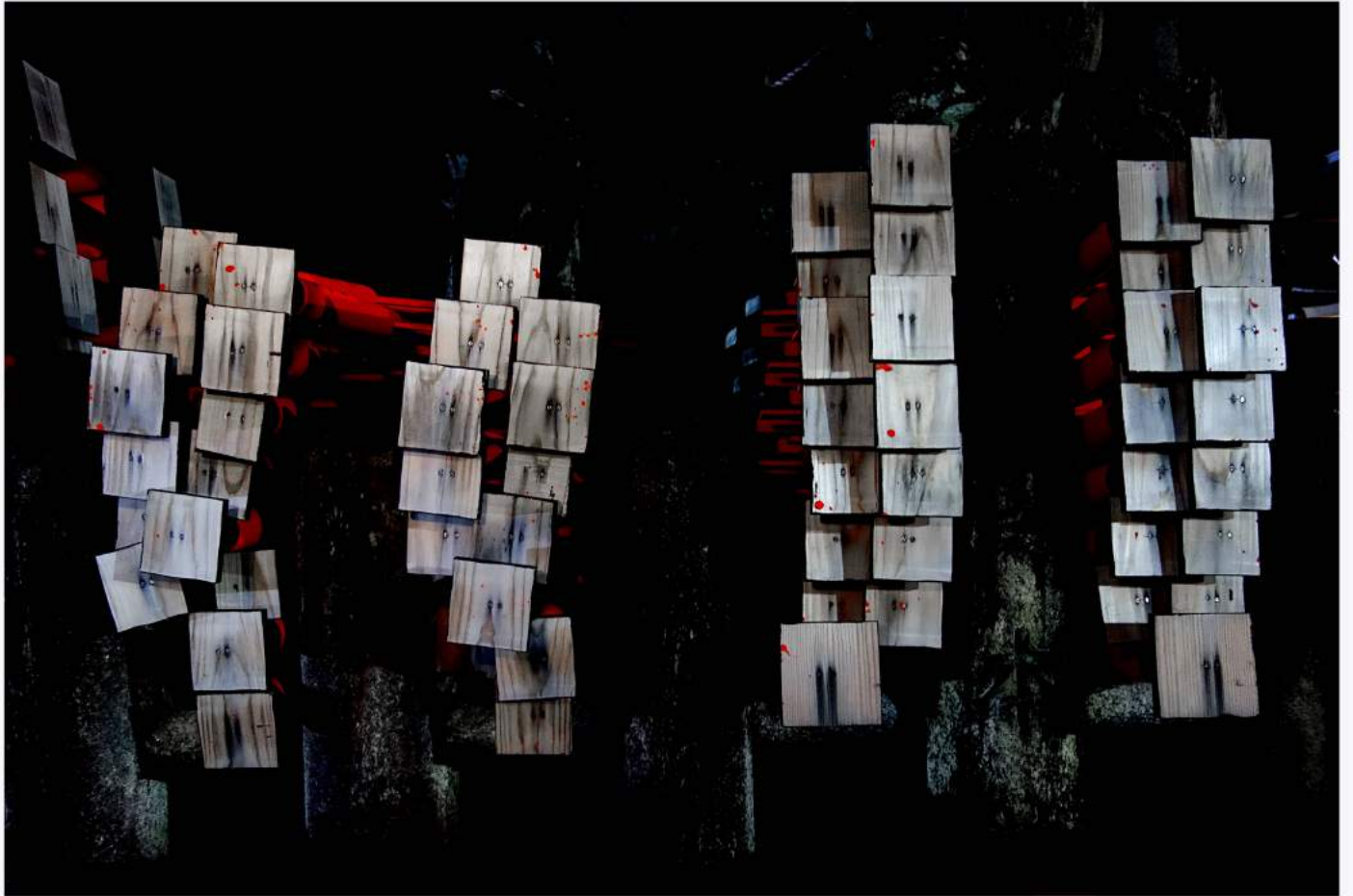

Près de Demachiyangi, 3 septembre 2022.



Derrière Monko-ji (la maison balafrée), 3 septembre 2022.

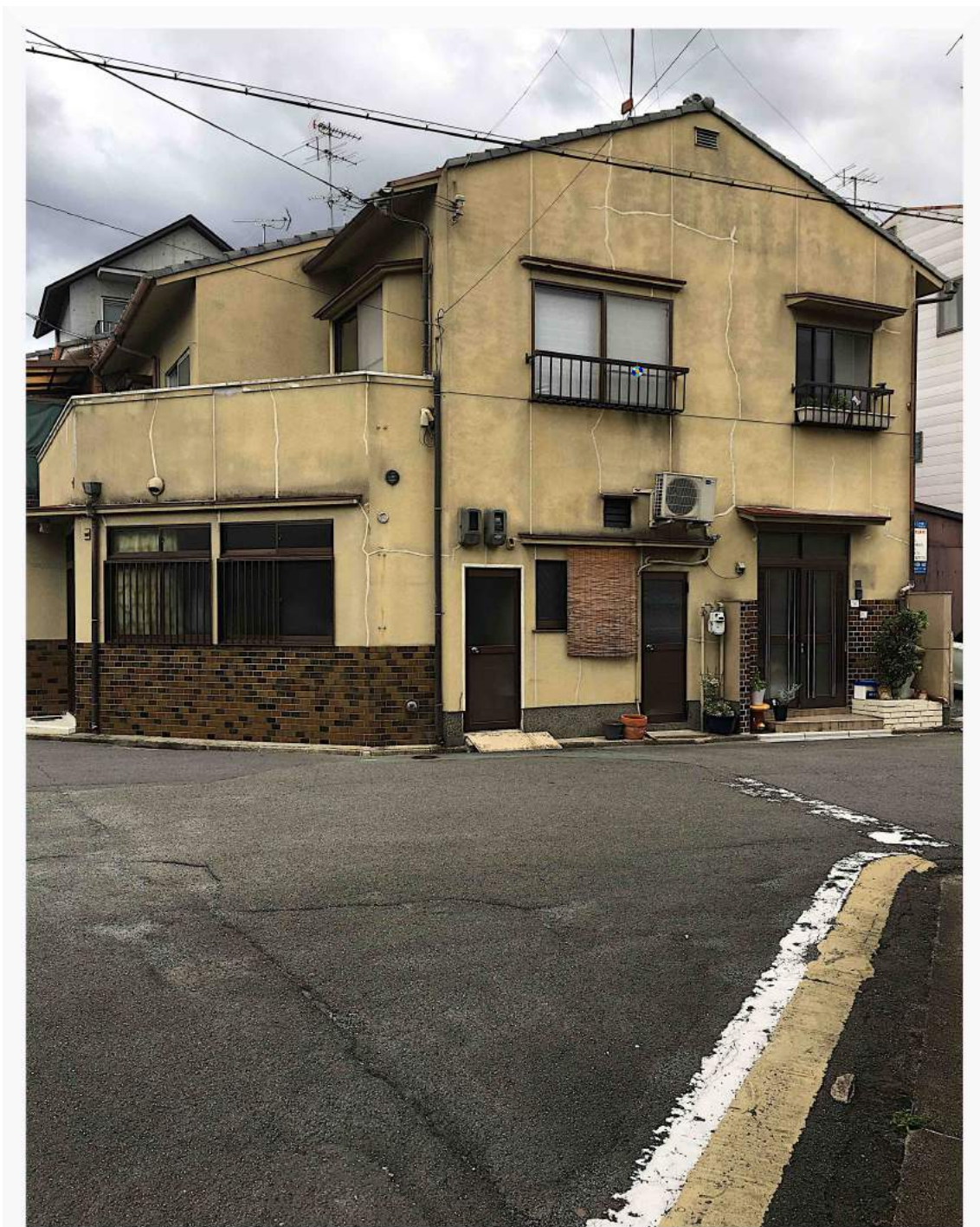



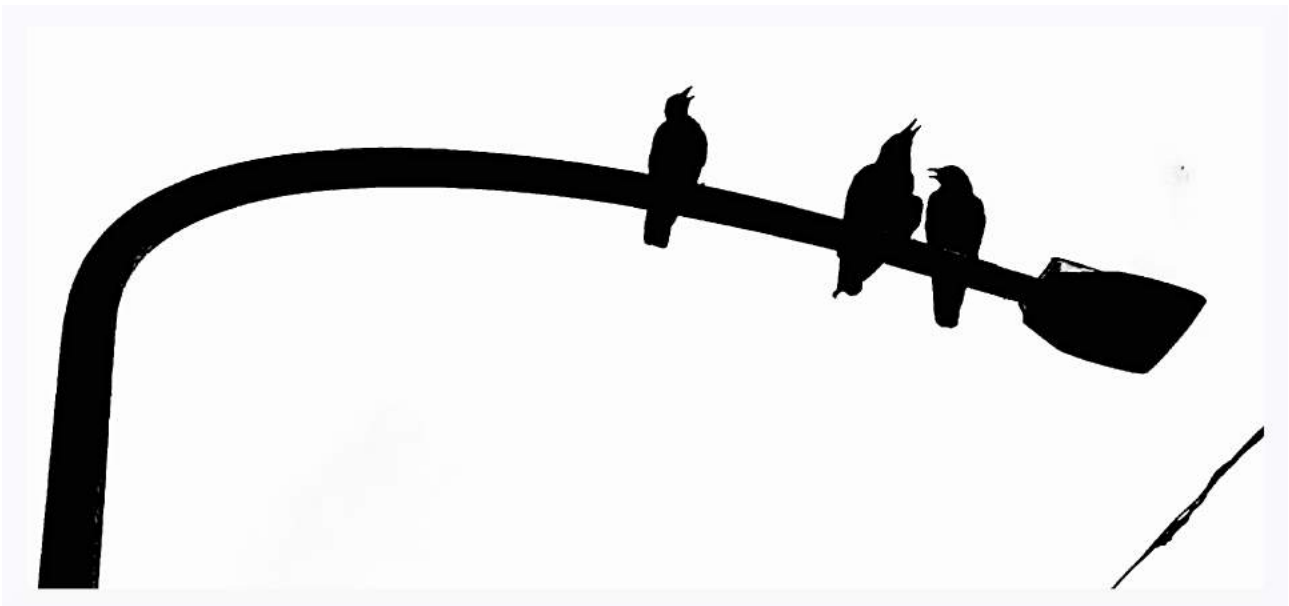
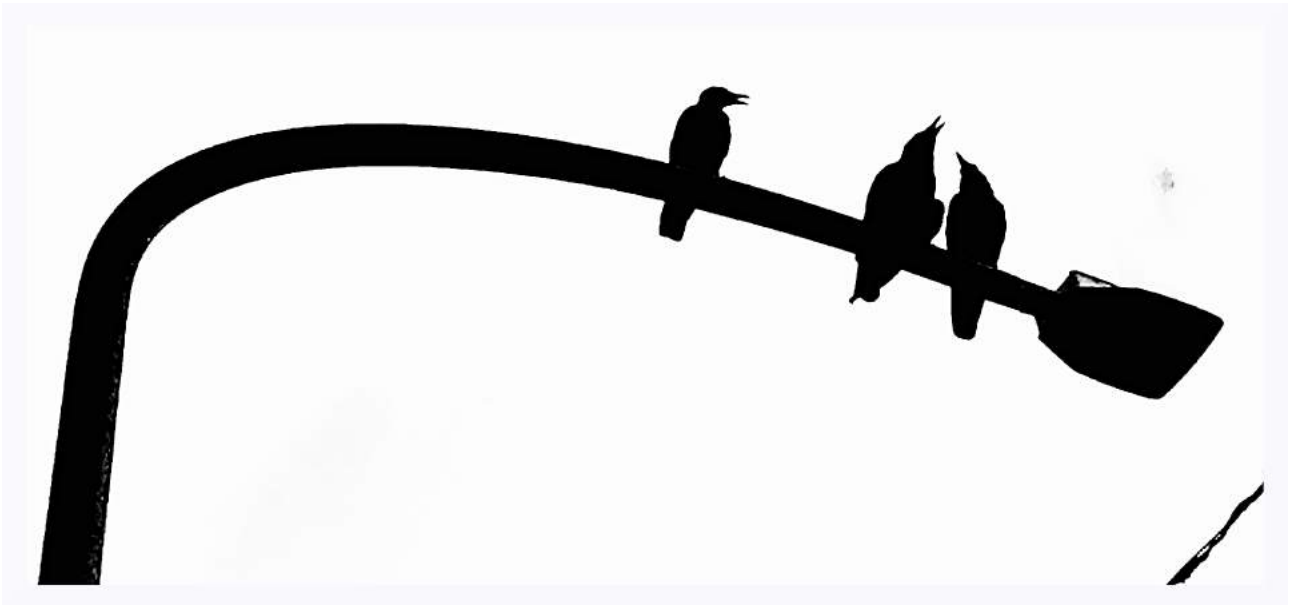
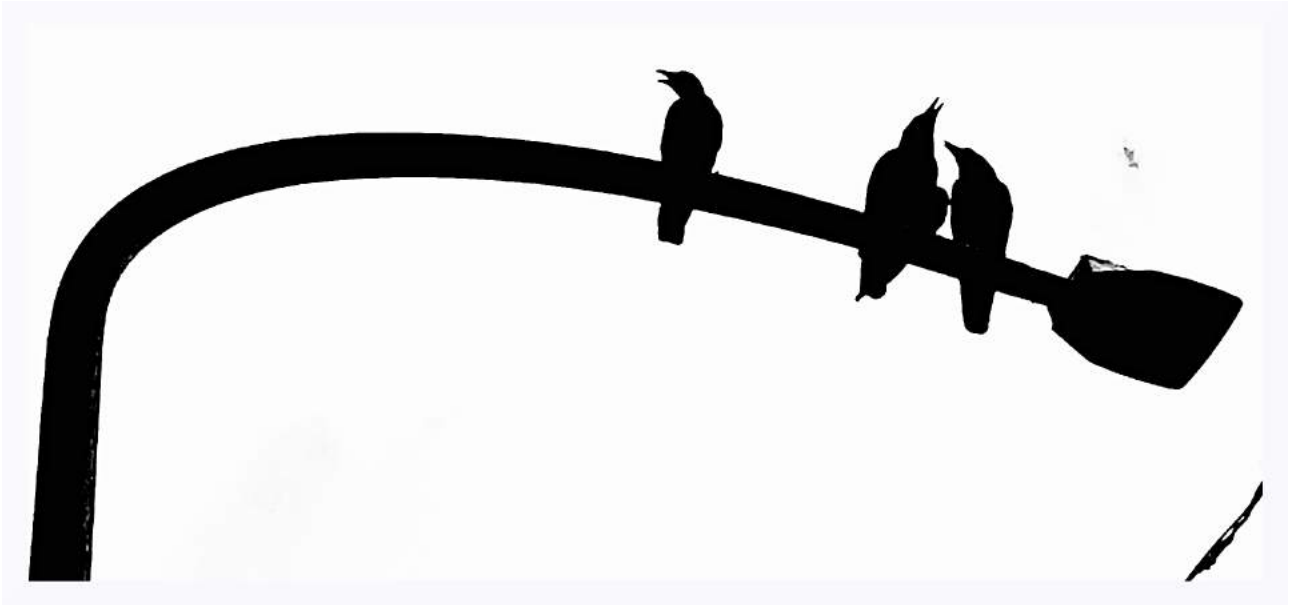

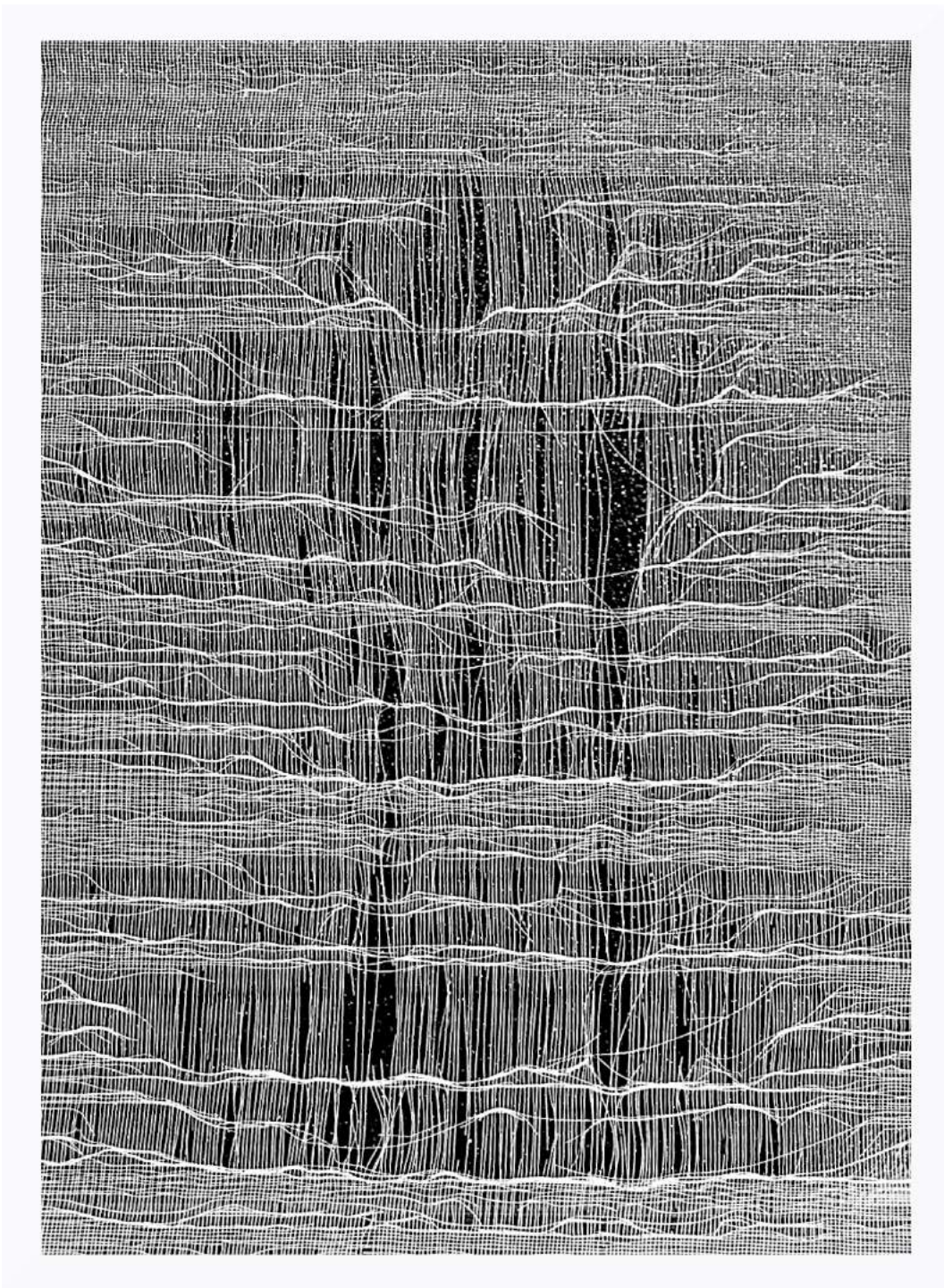

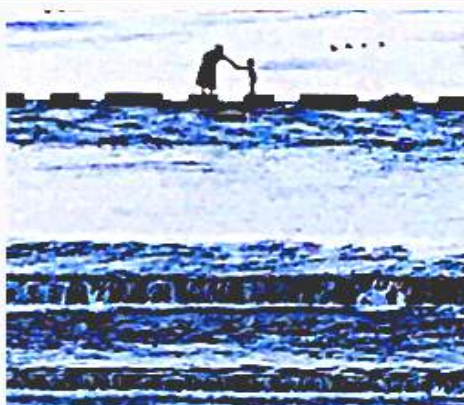
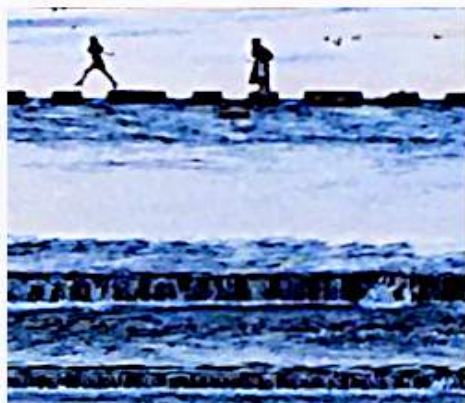



Entre Higashioji et Kawabata, au nord de Hyakumanben, 17 septembre 2022.

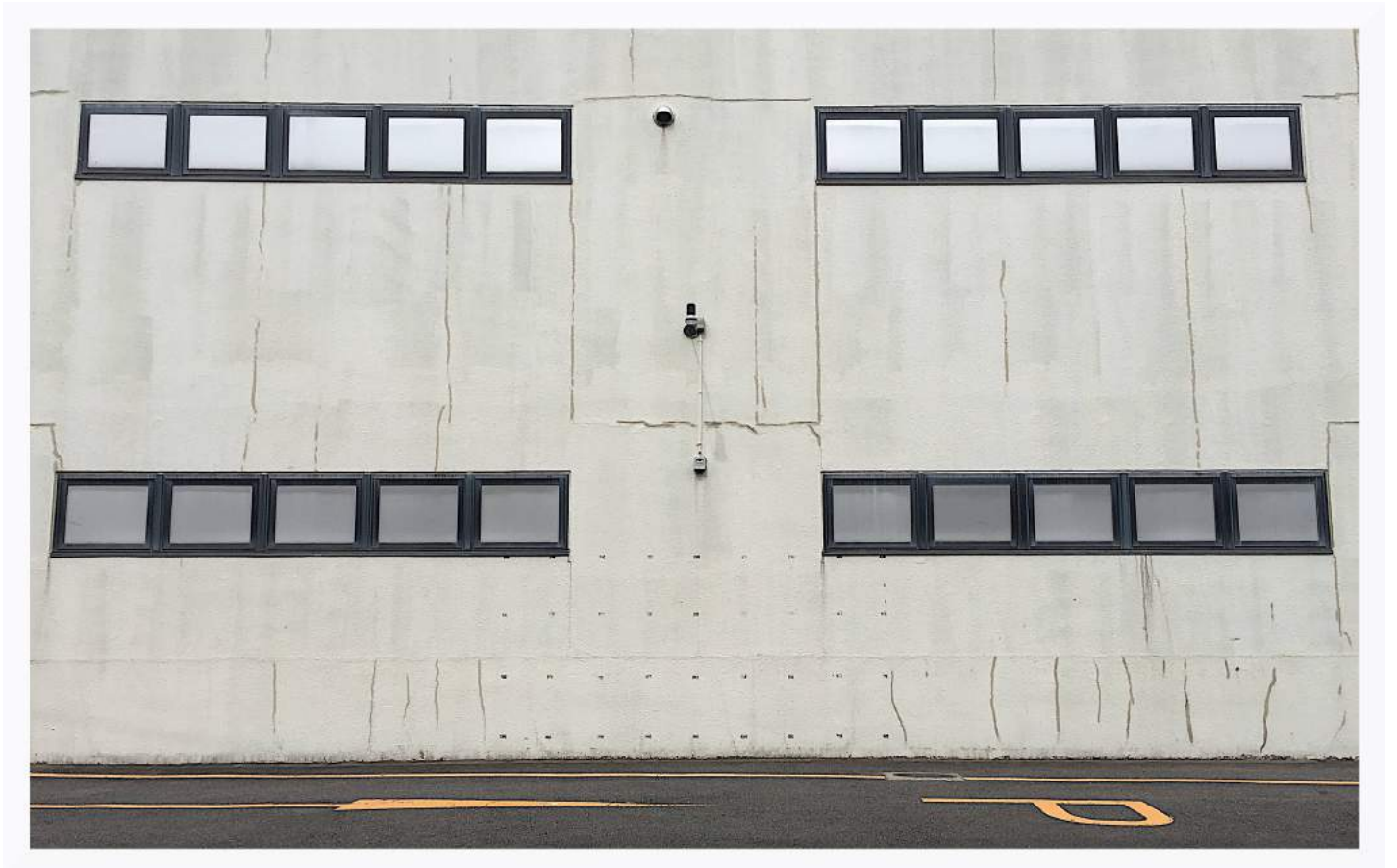

Osaka, 18 septembre 2022.

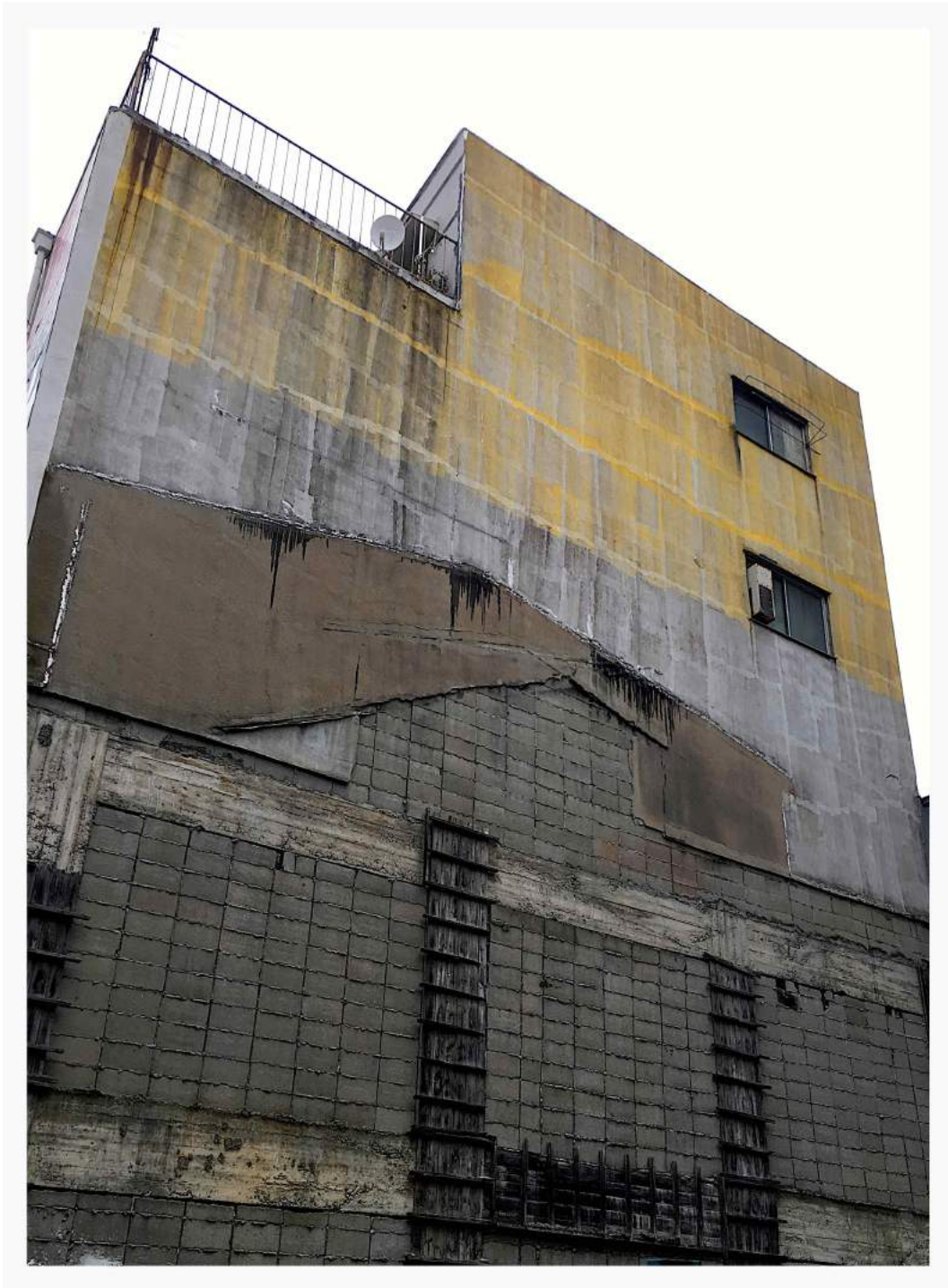

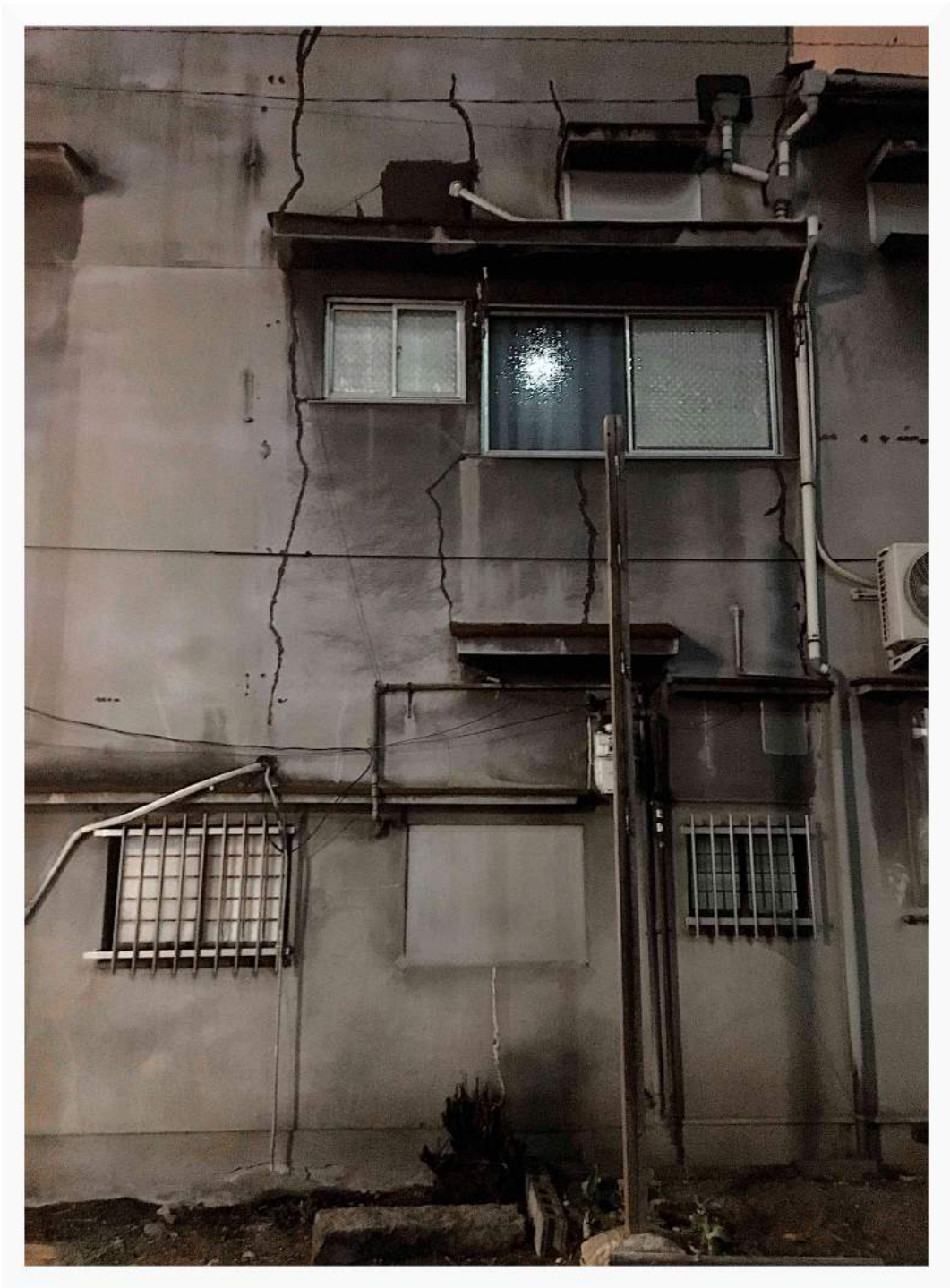



Près de Demachi Yanagi, 18 septembre 2022 - 3:00 du matin.













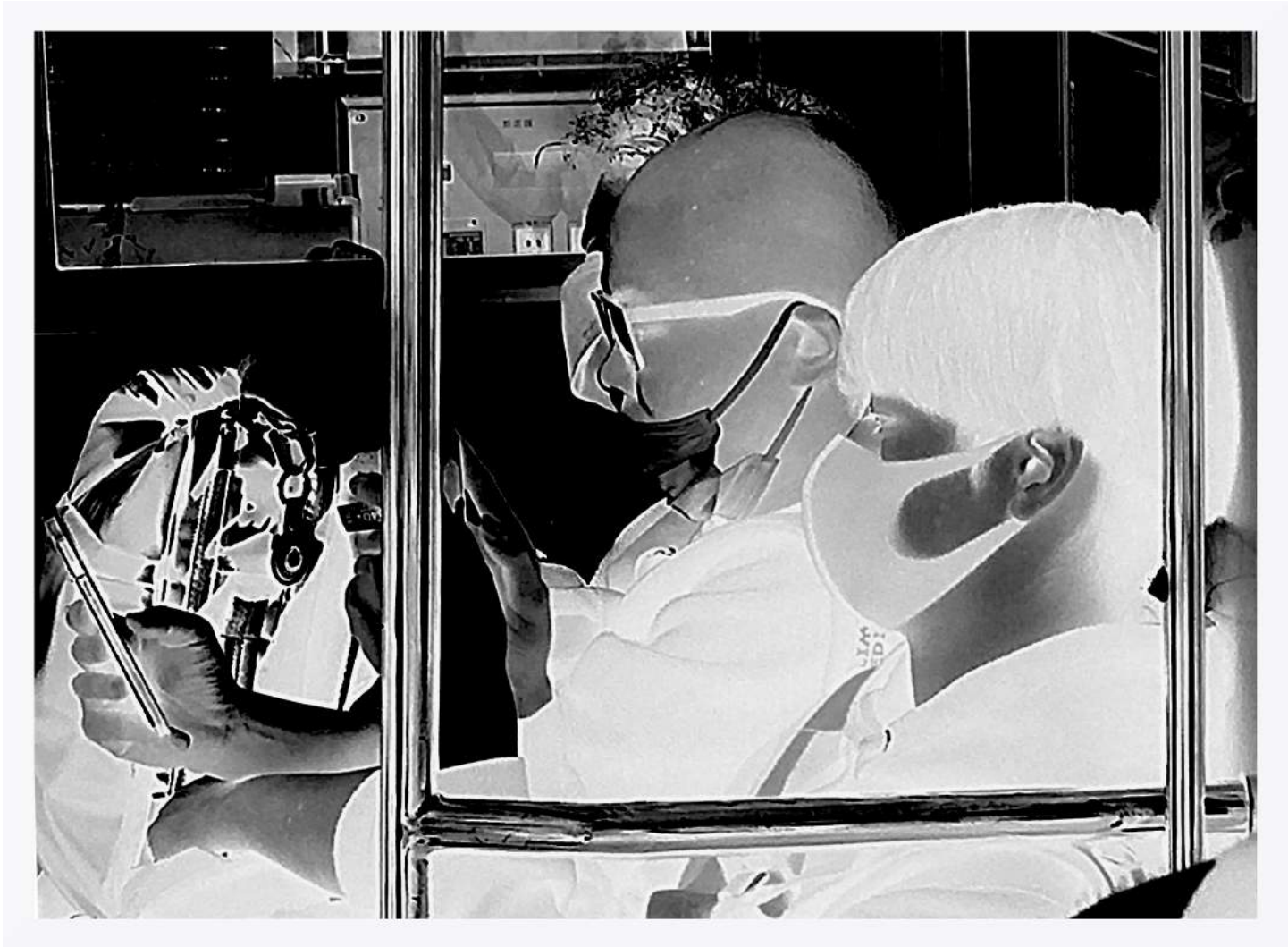

Haneda, 22 septembre 2022.



